

## **FOREWORD**

*The SUZUKI RG500 has been developed as a new generation motorcycle to the RG models. It is packed with highly advanced design concepts including a liquid cooled square four engine, a Suzuki Automatic Exhaust Control (S.A.E.C.), a Suzuki Intake Power Chamber (S.I.P.C.), a cartridge type transmission gear, a C.D. ignition system, a deca-piston brake system and a full-floater rear suspension. Combined with precise control and easy handling the RG500 provides excellent performance and outstanding riding comfort.*

*This service manual has been produced primarily for experienced mechanics whose job is to inspect, adjust, repair and service SUZUKI motorcycles. Apprentice mechanics and do-it-yourself mechanics, will also find this manual an extremely useful repair guide. This manual contains the most up-to-date information at the time of publication. The rights are reserved to update or make corrections to this manual at any time.*

**SUZUKI MOTOR CORPORATION**

*Motorcycle Technical  
Service Department*

# VIEW OF SUZUKI RG500

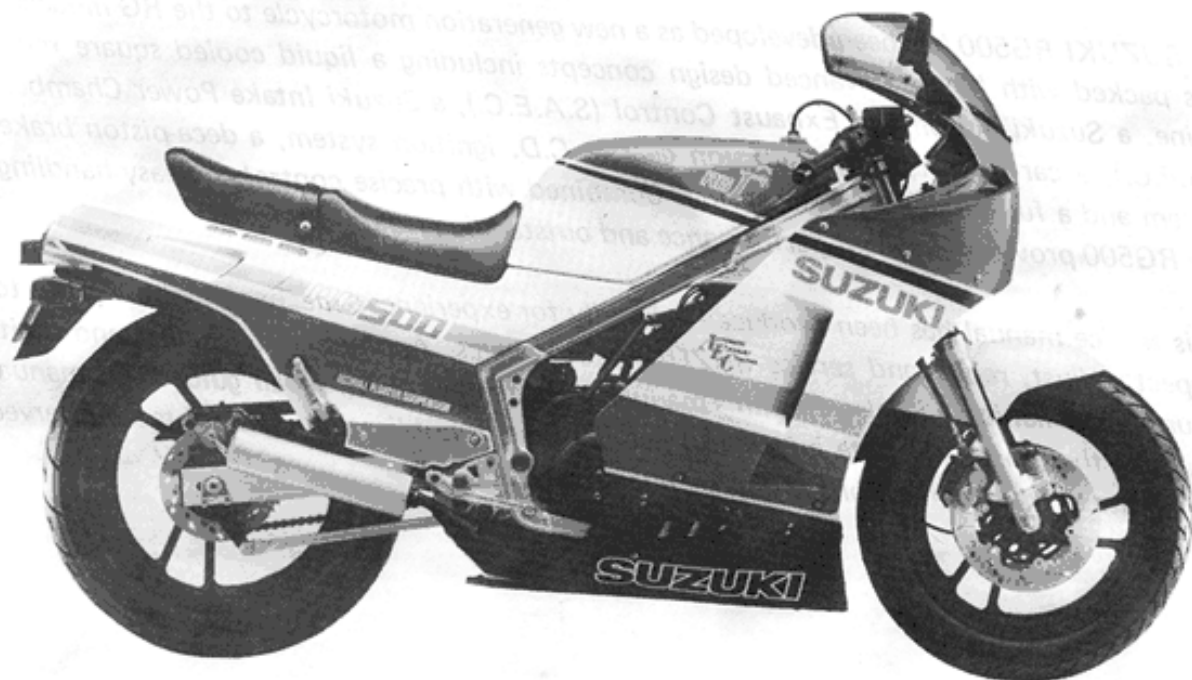

RIGHT SIDE

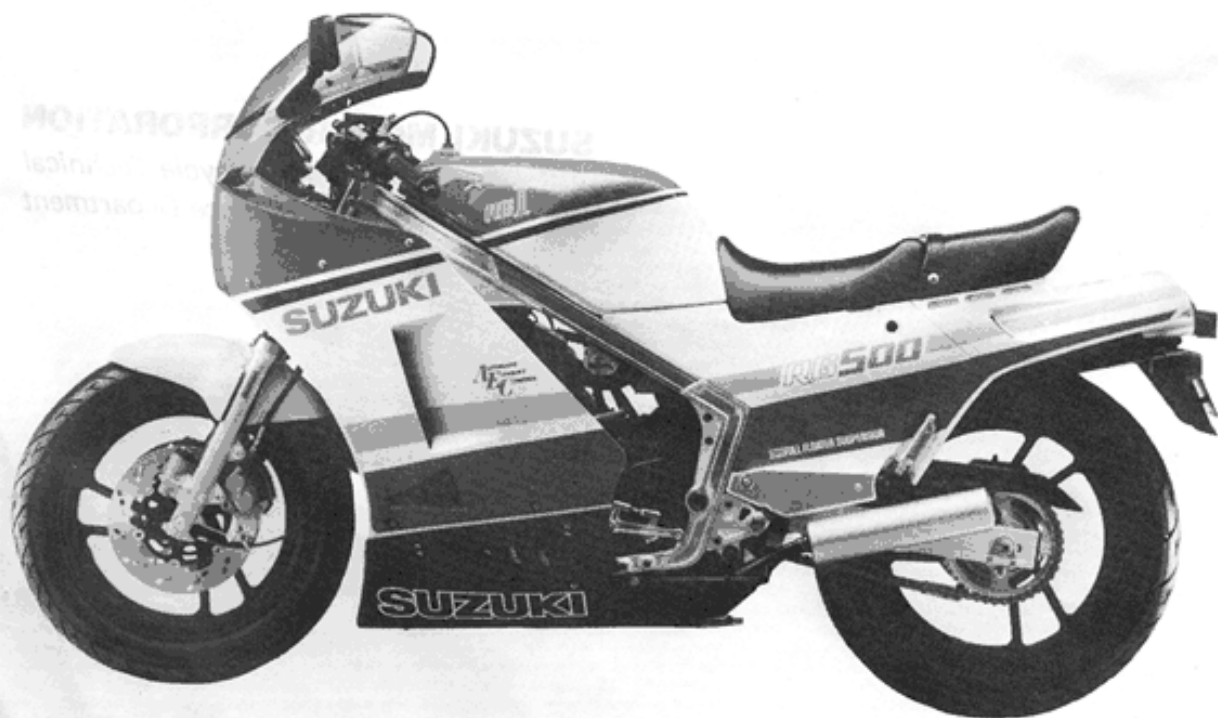

LEFT SIDE

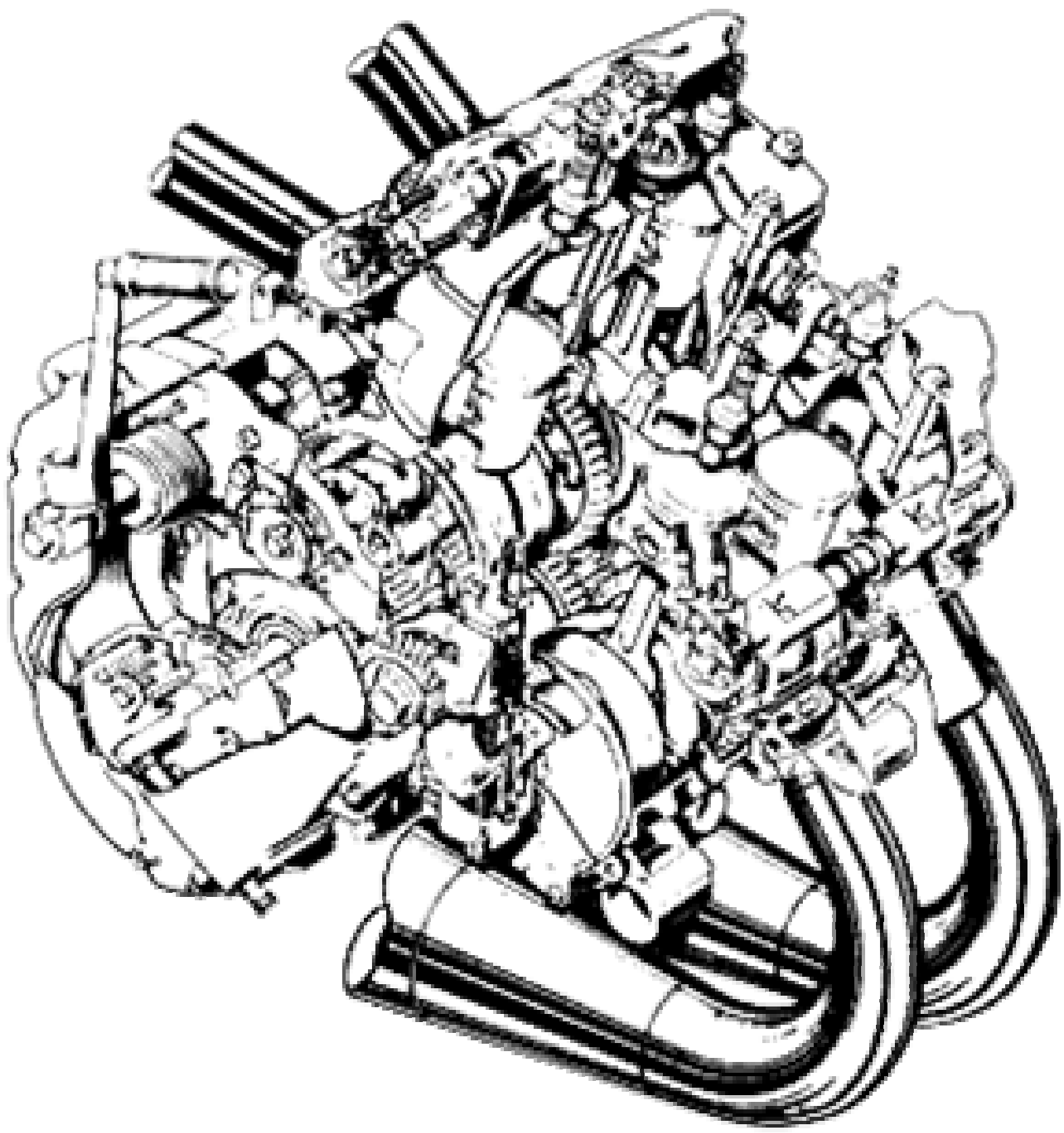

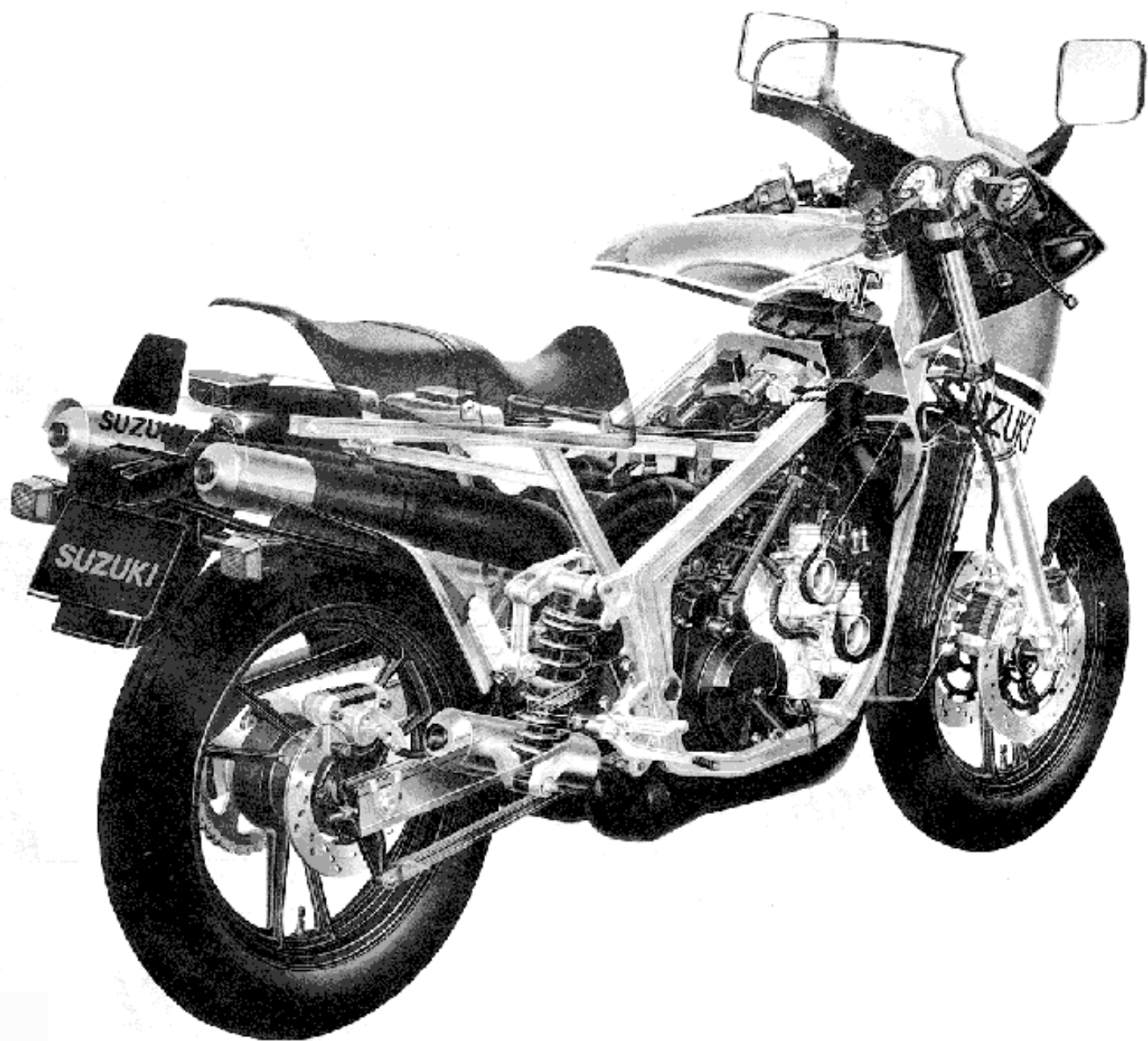

# GENERAL INFORMATION

## CONTENTS

<b>SERIAL NUMBER LOCATION</b> .....	<b>1- 1</b>
<b>FUEL, OIL AND COOLANT RECOMMENDATION</b> .....	<b>1- 1</b>
<b>BREAKING-IN PROCEDURES</b> .....	<b>1- 2</b>
<b>CYLINDER IDENTIFICATION</b> .....	<b>1- 2</b>
<b>SPECIAL MATERIALS</b> .....	<b>1- 3</b>
<b>PRECAUTION AND GENERAL INSTRUCTION</b> .....	<b>1- 5</b>
<b>SPECIFICATIONS</b> .....	<b>1- 6</b>

FUEL, OIL AND COOLANT  
RECOMMENDATION

## SERIAL NUMBER LOCATION

The frame serial number or V.I.N. (Vehicle Identification Number) ① is stamped on the steering head pipe. The engine serial number ② is located on the right side of the crankcase. These numbers are required especially for registering the machine and ordering spare parts.

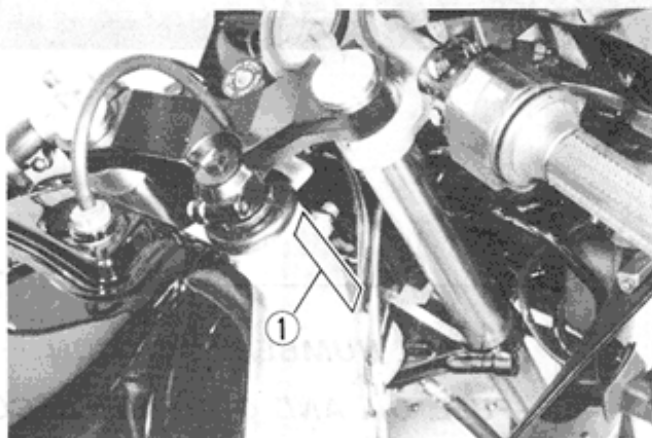

## FUEL, OIL AND COOLANT RECOMMENDATION

### FUEL

Gasoline used should be graded 85 – 95 octane or higher. An unleaded or low-lead gasoline type is recommended.

### ENGINE OIL

Use SUZUKI "CCI" oil or SUZUKI CCI Super oil. They are formulated to give best engine performance with least combustion chamber deposits, least preignition, maximum spark plug life and best lubrication. If they are not available, a good quality TWO-STROKE OIL (non-diluent type) should be used.

### TRANSMISSION OIL

Use a good quality SAE 20W/40 multi-grade motor oil.

### FRONT FORK OIL

Use fork oil # 15.

### BRAKE FLUID

Specification and classification:	SAE J1703, DOT3 or DOT4
-----------------------------------	-------------------------

#### WARNING:

- \* Since the brake system of this motorcycle is filled with a glycol-based brake fluid by the manufacturer, do not use or mix different types of fluid such as silicone-based and petroleum-based fluid for refilling the system, otherwise serious damage will result.
- \* Do not use any brake fluid taken from old or used or unsealed containers.
- \* Never re-use brake fluid left over from the previous servicing and stored for a long period.

99000-99044-15G

SUZUKI Fork oil # 15

### COOLANT

Use an anti-freeze/coolant compatible with an aluminum radiator, mixed with distilled water only, at the ratio of 50 : 50.

### WATER FOR MIXING

Use distilled water only. Water other than distilled water can corrode and clog the aluminum radiator.

### ANTI-FREEZE/COOLANT

The coolant performs as corrosion and rust inhibitor as well as anti-freeze. Therefore, the coolant should be used at all times even through the atmospheric temperature in your area does not go down to freezing point.

SUZUKI recommends the use of SUZUKI GOLD-EN CRUISER 1 200 anti-freeze/coolant. If this is not available, use an equivalent which is compatible with an aluminum radiator.

### REQUIRED AMOUNT OF WATER/COOLANT

Solution capacity (total): 2 250 ml

#### CAUTION:

Mixing of anti-freeze/coolant should not exceed 60%. Mixing beyond it would reduce its efficiency. If the anti-freeze/coolant mixing ratio is below 50%, the rust inhibiting performance is greatly reduced. Be sure to mix the solution at 50%, even though the atmospheric temperature does not go down to freezing point.

Every new unit contains Bar's leak material.

## BREAKING-IN PROCEDURES

During manufacture only the best possible materials are used and all machined parts are finished to a very high standard, but it is still necessary to allow the moving parts to "BREAK-IN" before subjecting the engine to maximum stresses. The future performance and reliability of the engine depends on the care and restraint exercised during its early life. The general rules are as follows:

- Keep to these breaking-in engine speed limits:

Initial 800 km	Below 6 000 r/min
Up to 1 600 km	Below 8 000 r/min
Over 1 600 km	Below 10 000 r/min

- Upon reaching an odometer reading of 1 600 km you can subject the motorcycle to full throttle operation. However, do not exceed 10 000 r/min at any time.



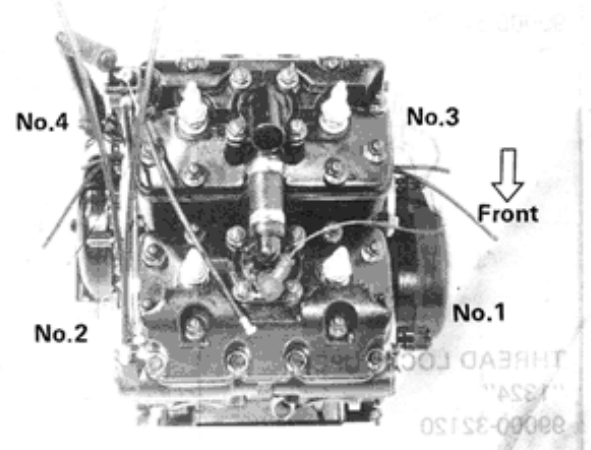

## CYLINDER IDENTIFICATION





The four cylinders of this engine are identified as No. 1, No. 2, No. 3 and No. 4 cylinder, as shown in the photograph.



## SPECIAL MATERIALS

The materials listed below are needed for maintenance work on the RG500, and should be kept on hand for ready use. They supplement such standard materials as cleaning fluids, lubricants, emery cloth and the like. How to use them and where to use them are described in the text of this manual.

MATERIAL	PART	PAGE	PART	PAGE
 <p>SUZUKI SUPER GREASE "A" 99000-25010</p>	<ul style="list-style-type: none"> <li>● Side stand pivot</li> <li>● Brake pedal pivot and brake rod link</li> <li>● Gearshift lever mounting boss</li> <li>● Oil seals</li> <li>● Kick starter gear</li> <li>● Kick starter shaft oil seal</li> <li>● Rotary disc valve O-ring</li> <li>● Kick starter lever steel balls</li> <li>● Water pump shaft oil seal</li> </ul>	<p>2- 2</p> <p>3- 8</p> <p>3-35</p> <p>3-41</p> <p>3-37</p> <p>3-42</p> <p>3-45</p> <p>3-50</p> <p>4- 9</p>	<ul style="list-style-type: none"> <li>● Wheel bearing</li> <li>● Steering stem bearing</li> <li>● Rear sprocket mounting drum bearing</li> <li>● Swingarm, cushion lever bearing</li> </ul>	<p>7- 7</p> <p>7-27</p> <p>7-40</p> <p>7-57</p>
 <p>SUZUKI BOND No. 1207B 99000-31140</p>	<ul style="list-style-type: none"> <li>● Crankcase mating surface</li> <li>● Water pump mechanical seal</li> <li>● Water temp. gauge</li> </ul>	<p>3-44</p> <p>4- 9</p> <p>4-12</p>		
 <p>THREAD LOCK SUPER "1333" 99000-32020</p>	<ul style="list-style-type: none"> <li>● Gearshift cam pin retainer plate screw</li> <li>● Gearshift cam stopper bolt</li> <li>● Water pump shaft housing screw</li> </ul>	<p>3-36</p> <p>3-36</p> <p>4-10</p>		
 <p>THREAD LOCK SUPER "1324" 99000-32120</p>	<ul style="list-style-type: none"> <li>● Magneto rotor nut</li> </ul>	<p>3-46</p>		

MATERIAL	PART	PAGE	PART	PAGE
 <p>THREAD LOCK "1360" 99000-32130</p>	<ul style="list-style-type: none"> <li>• Disc plate bolt</li> </ul>	<p>7- 8 7-41</p>		
 <p>THREAD LOCK "1342" 99000-32050</p>	<ul style="list-style-type: none"> <li>• Bearing stopper screw</li> <li>• Inner valve seat screw</li> <li>• Magneto stator screw</li> <li>• Damper rod bolt</li> <li>• Posi-damp unit bolt</li> </ul>	<p>3-36 3-45 3-46 7-21 7-21</p>		
 <p>SUZUKI BRAKE FLUID 99000-23021</p>				
 <p>SUZUKI FORK OIL # 15 99000-99044-15G</p>				
 <p>SUZUKI GOLDEN CRUISER 1200 (2L) 99000-24120</p>	<ul style="list-style-type: none"> <li>• Coolant</li> </ul>			
<p>SUZUKI BAR's LEAK 99000-24240</p>	<ul style="list-style-type: none"> <li>• Coolant</li> </ul>	<p>4- 2</p>		

## PRECAUTION AND GENERAL INSTRUCTION

Observe the following items without fail when servicing, disassembling and reassembling motorcycles.

- Do not run engine indoors with little or no ventilation.
- Be sure to replace packings, gaskets, circlips, O-rings and cotter pins with new ones.

### CAUTION:

Never reuse a circlip. After a circlip has been removed from a shaft, it should be discarded and a new circlip must be installed.

When installing a new circlip, care must be taken not to expand the end gap larger than required to slip the circlip over the shaft.

After installing a circlip, always insure that it is completely seated in its groove and securely fitted.

- Tighten cylinder head and case bolts and nuts beginning with larger diameter and ending with smaller diameter, and from inside to outside diagonally, to the specified tightening torque.
- Use special tools where specified.
- Use genuine parts and recommended oils.
- When 2 or more persons work together, pay attention to the safety of each other.
- After the reassembly, check parts for tightness and operation.
- Treat gasoline, which is extremely flammable and highly explosive, with greatest care. Never use gasoline as cleaning solvent.

Warning, Caution and Note are included in this manual occasionally, describing the following contents.

**WARNING** ..... When personal safety of the rider is involved, disregard of the information could result in injury.

**CAUTION** ..... For the protection of the motorcycle, the instruction or rule must be strictly adhered to.

**NOTE** ..... Advice calculated to facilitate the use of the motorcycle is given under this heading.

### USE OF GENUINE SUZUKI PARTS

To replace any part of the machine, use a genuine SUZUKI replacement part. Imitation parts or parts supplied from any other source than SUZUKI, if used to replace SUZUKI parts can reduce the machine's performance and, even worse, could induce costly mechanical troubles.

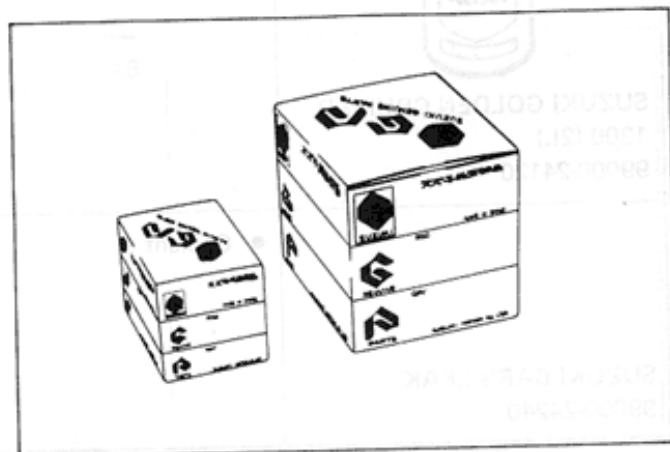

## SPECIFICATIONS

### DIMENSIONS AND DRY MASS

Overall length	2100 mm
Overall width	695 mm
Overall height	1185 mm
Wheelbase	1425 mm
Ground clearance	120 mm
Dry mass	154 kg

### ENGINE

Type	Two-stroke, water-cooled
Number of cylinders	4
Bore	56.0 mm
Stroke	50.6 mm
Piston displacement	498 cm <sup>3</sup>
Compression ratio	7.0 : 1
Carburetor	MIKUNI VM28SH
Air cleaner	Polyurethane foam element
Starter system	Kick
Lubrication system	SUZUKI "CCI"

### TRANSMISSION

Clutch	Wet multi-plate type
Transmission	6-speed constant mesh
Gearshift pattern	1-down, 5-up
Pilot drive and driven gear ratio	1.000 (54/54)
Primary reduction	2.230 (58/26)
Final reduction	2.500 (40/16)
Gear ratios, Low	2.636 (29/11)
2nd	1.750 (28/16)
3rd	1.380 (29/21)
4th	1.173 (27/23)
5th	1.045 (23/22)
Top	0.956 (22/23)
Drive chain	DAIDO : DID 50VA TAKASAGO: RK50 HFO 106 links

### CHASSIS

Front suspension	Telescopic pneumatic/coil spring oil damped with posi-damp unit. Spring pre-load adjustable.
------------------	--

Rear suspension	Full-floating suspension system, oil damped, spring pre-load fully adjustable
Steering angle	30° (right & left)
Caster	64°50'
Trail	110 mm
Turning radius	3.2 m
Front brake	Disc brake, twin
Rear brake	Disc brake
Front tire size	110/90V 16
Rear tire size	120/90V 17
Front fork stroke	130 mm
Rear wheel travel	127 mm

### ELECTRICAL

Ignition type	SUZUKI "PEI"
Ignition timing	14° B.T.D.C. below 1700 r/min, 26° B.T.D.C. (2700 - 6000 r/min.) and 11° B.T.D.C. above 9500 r/min.
Spark plug	N.G.K.: B9ES... E01 N.G.K.: BR9ES... The others
Battery	12V 14.4KC (4Ah)/10HR
Generator	Three-phase A.C. generator
Fuse	20A

### CAPACITIES

Fuel tank including reserve	22 L
reserve	5.0 L
Engine oil	1.5 L
Transmission oil	800 ml
Coolant	2250 ml
Front fork oil	441 ml

## 1-7 GENERAL INFORMATION

---

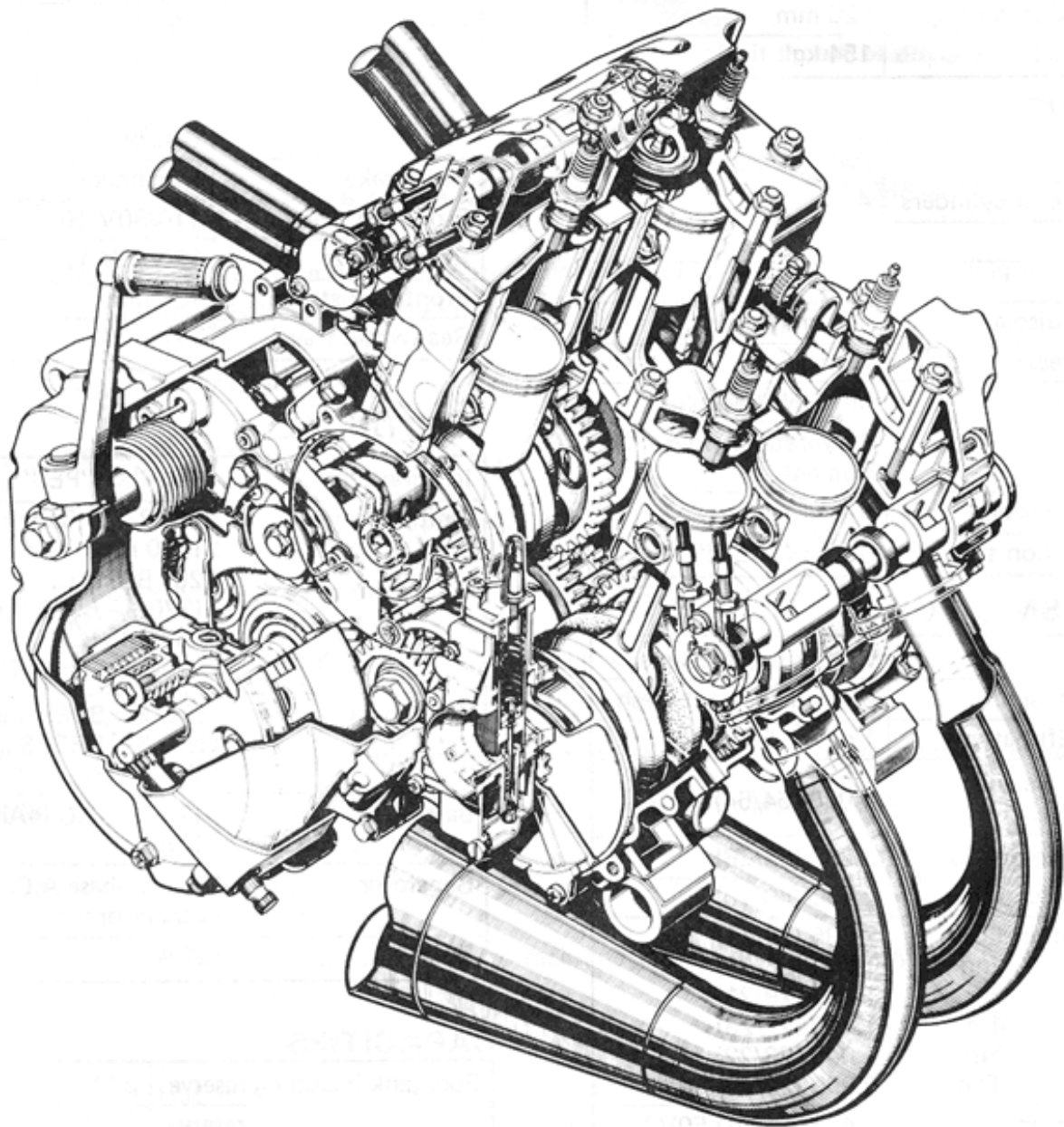

# PERIODIC MAINTENANCE AND TUNE-UP PROCEDURES

## CONTENTS

PERIODIC MAINTENANCE SCHEDULE	2-1
PERIODIC MAINTENANCE CHART	2-1
LUBRICATION POINTS	2-2
MAINTENANCE AND TUNE-UP PROCEDURES	2-3
BATTERY	2-3
ENGINE BOLTS AND NUTS	2-3
CYLINDER HEAD, CYLINDER AND MUFFLER	2-4
AIR CLEANER	2-4
SPARK PLUGS	2-5
CARBURETORS	2-6
FUEL LINES	2-7
OIL PUMP	2-8
CLUTCH	2-8
TRANSMISSION OIL	2-9
COOLING SYSTEM	2-10
DRIVE CHAIN	2-11
BRAKES	2-12
TIRES	2-15
STEERING	2-16
FRONT FORK	2-16
REAR SUSPENSION	2-16
CHASSIS BOLTS AND NUTS	2-17

## PERIODIC MAINTENANCE SCHEDULE

The chart below lists the recommended intervals for all the required periodic service work necessary to keep the motorcycle operating at peak performance and economy. Mileages are expressed in terms of kilometers.

**NOTE:**

Vehicles operated under severe conditions may require more frequent servicing.

### PERIODIC MAINTENANCE CHART

This interval should be judged by odometer reading or months, whichever comes first.	km	1 000	6 000	12 000	18 000	24 000
	months	2	12	24	36	48
Battery		—	I	I	I	I
Engine bolts and nuts		T	T	T	T	T
Cylinder head, cylinder and muffler		—	C	C	C	C
Air cleaner		Clean every 3 000 km				
Spark plugs		I	R	R	R	R
Carburetors		I	I	I	I	I
Fuel lines		I	I	I	I	I
		Replace every 4 years				
Oil pump		I	I	I	I	I
Clutch		I	I	I	I	I
Transmission oil		R	—	R	—	R
Radiator hoses		I	—	I	—	I
		Replace every 4 years				
Coolant		Replace every 2 years				
Drive chain		I	I	I	I	I
		Clean and lubricate every 1 000 km				
Brakes		I	I	I	I	I
Brake hoses		I	I	I	I	I
		Replace every 4 years				
Brake fluid		Replace every 2 years				
Tires		I	I	I	I	I
Steering		I	I	I	I	I
Front fork		—	—	I	—	I
		Inspect air pressure every 6 months				
Rear suspension		—	—	I	—	I
Chassis bolts and nuts		T	T	T	T	T

T: Tighten, I: Inspect, R: Replace, C: Clean

## LUBRICATION POINTS

Proper lubrication is important for smooth operation and long life of each working part of the motorcycle. Major lubrication points are indicated below.

**NOTE:**

- \* Before lubricating each part, clean off any rusty spots and wipe off any grease, oil, dirt or grime.
- \* Lubricate exposed parts which are subject to rust, with motor oil or grease.

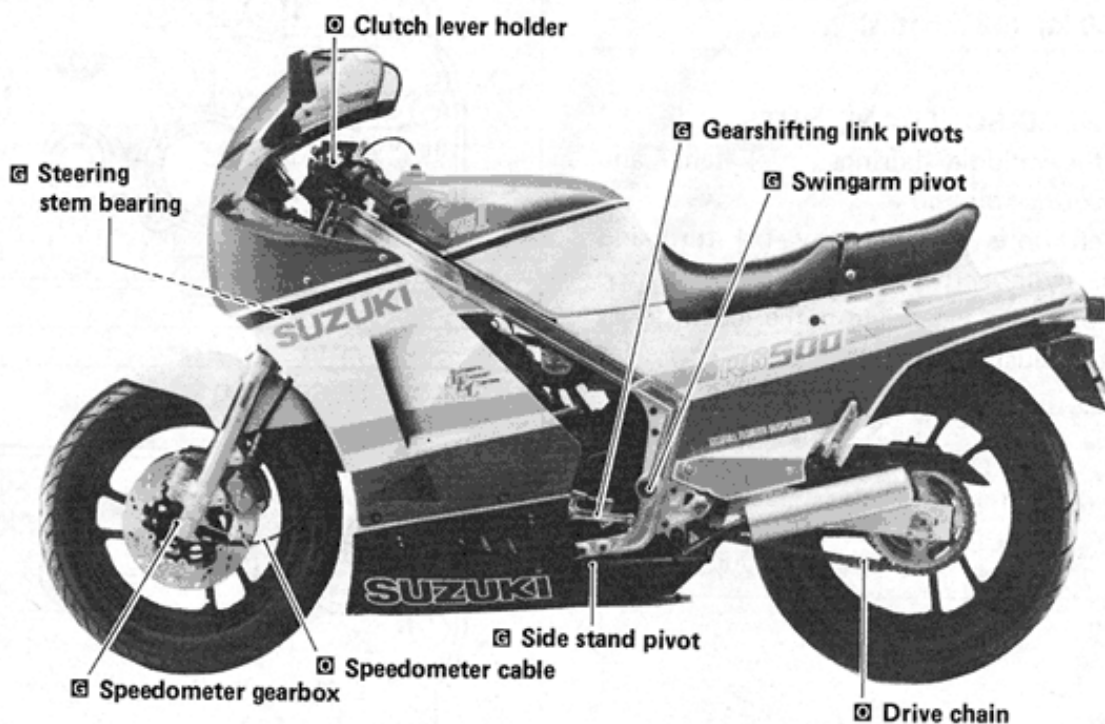
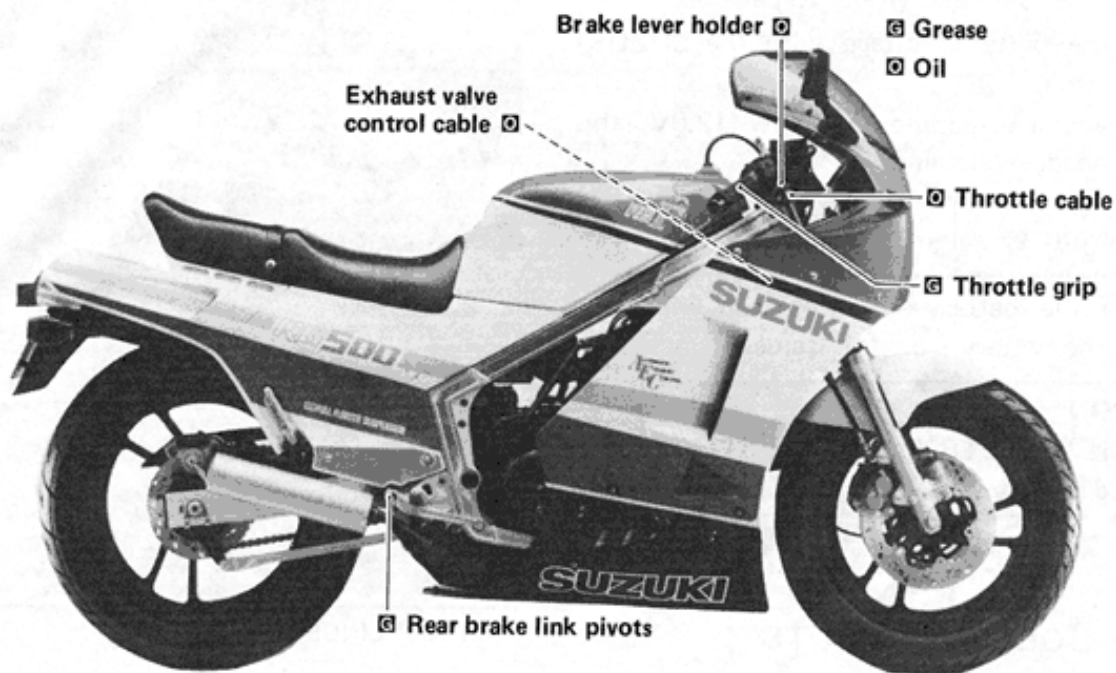

## MAINTENANCE AND TUNE-UP PROCEDURES

This section describes the service procedures for each section of Periodic Maintenance.

### BATTERY

Inspect Every 6000 km (12 months)

- Remove the fuel tank. (Refer to page 3-2)
- Check the battery voltage with the SUZUKI pocket tester.  
If the voltage reading is below 12.0V, this battery needs recharging.

Battery voltage	Above 12.0V
-----------------	-------------

- Remove the battery  $\ominus$  and  $\oplus$  lead wires and remove the battery from the frame.

**CAUTION:**

Read the "ELECTRICAL SECTION", for the servicing battery.

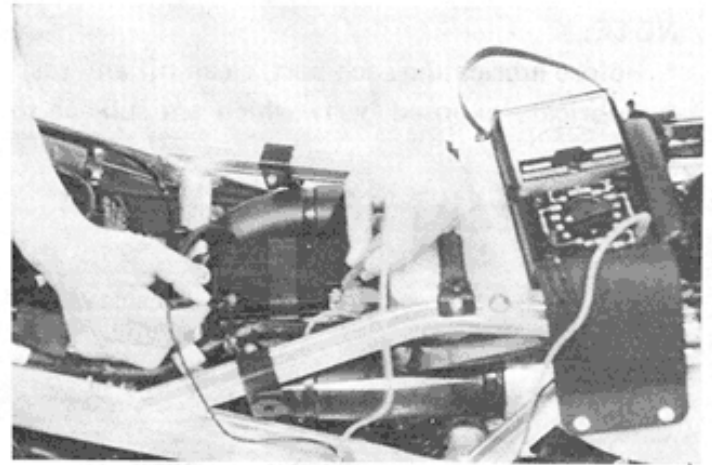

### ENGINE BOLTS AND NUTS

Tighten at Initially 1 000 km (2 months) and Every 6 000 km (12 months)

#### CYLINDER HEAD BOLTS AND NUTS

- Remove the middle fairings, fuel tank and air cleaner outlet pipes.
- First loosen bolts and nuts by 1/4 turn and tighten the cylinder head bolts and nuts to the specified torque in ascending numerical order as shown in the illustration.

Tightening torque	Bolt	10 – 12 N·m (1.0 – 1.2 kg·m)
	Nut	20 – 24 N·m (2.0 – 2.4 kg·m)

REAR CYLINDER HEAD

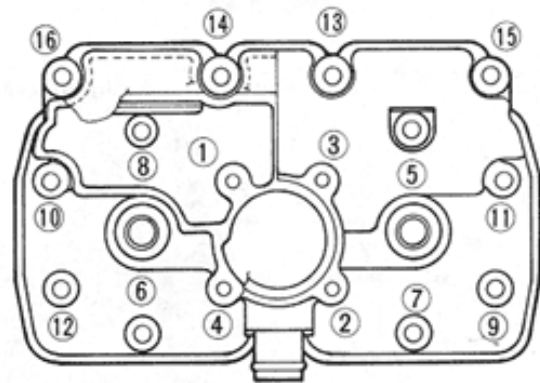

FRONT CYLINDER HEAD

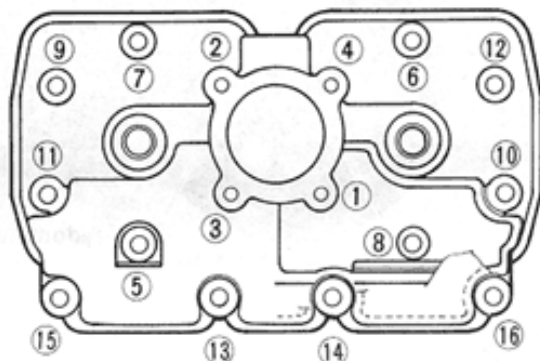

### EXHAUST PIPE BOLTS AND NUTS

- Remove the radiator. (See page 3-3)
- Tighten the exhaust pipe bolts and nuts to the specified torque.

Tightening torque	24 – 28 N·m (2.4 – 2.8 kg·m)
-------------------	---------------------------------

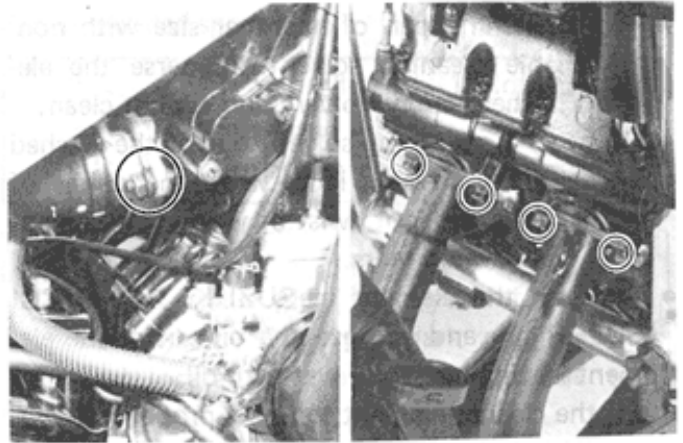

### CYLINDER HEAD, CYLINDER AND MUFFLER

Clean Every 6 000 km (12 months)

- Carbon deposits in the combustion chamber of the cylinder head and at the piston crown will raise the compression ratio and may cause pre-ignition or overheating.
- Carbon deposited at the exhaust port of the cylinder will prevent the flow of exhaust gas, reducing the output. Remove carbon deposits periodically.

### AIR CLEANER

Clean Every 3 000 km

- Remove the fuel tank. (Refer to page 3-2)
- Remove the air cleaner then separate the polyurethan foam element from the element frame.

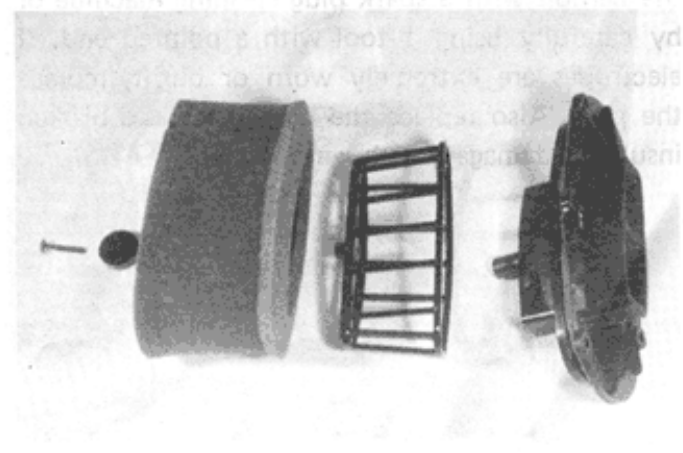
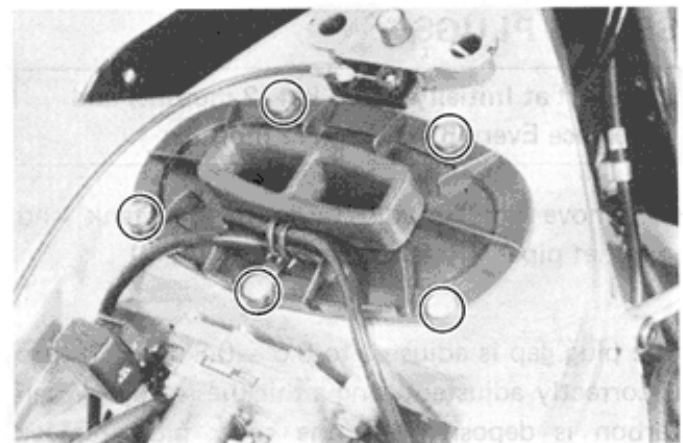
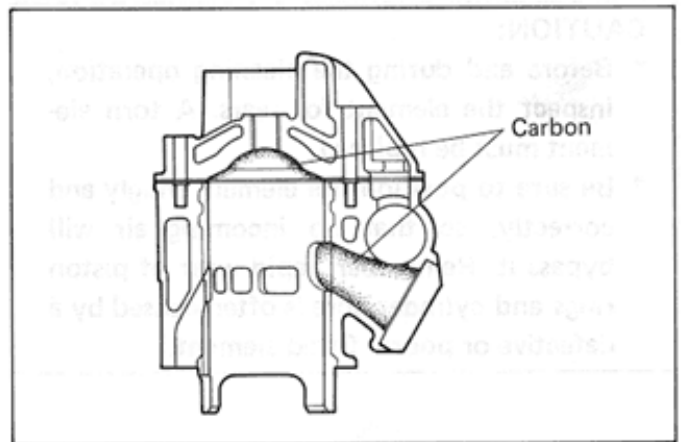

## 2-5 PERIODIC MAINTENANCE AND TUNE-UP PROCEDURES

- Fill a washing pan of a proper size with non-flammable cleaning solvent. Immerse the element in the cleaning solvent and wash it clean.
- Squeeze the cleaning solvent out of the washed element by pressing it between the palms of both hands: do not twist or wring the element or it will develop tears.
- Immerse the element in SUZUKI CCI or CCI SUPER oil, and squeeze the oil out of the element leaving it slightly wet with oil.
- Fit the cleaner element to frame properly.

### CAUTION:

- \* Before and during the cleaning operation, inspect the element for tears. A torn element must be replaced.
- \* Be sure to position the element snugly and correctly, so that no incoming air will bypass it. Remember, rapid wear of piston rings and cylinder bore is often caused by a defective or poorly fitted element.

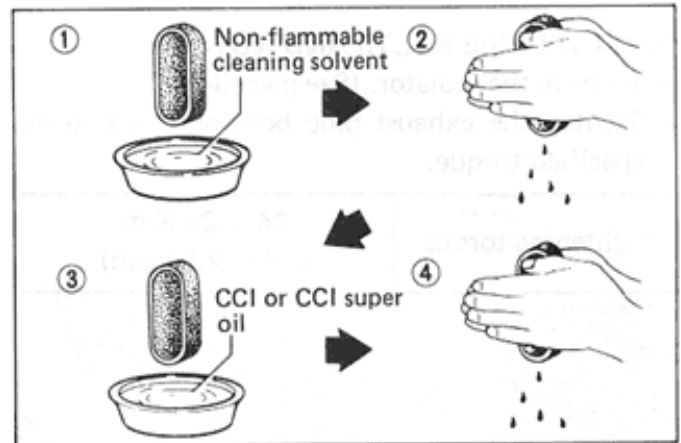

### CAUTION:

If driving under dusty conditions, clean the air cleaner element more frequently. The surest way to accelerate engine wear is to use the engine without the element or to use a ruptured element. Make sure that the air cleaner is in good condition at all times. Life of the engine depends largely on this component!

## SPARK PLUGS

Inspect at Initially 1 000 km (2 months) and Replace Every 6 000 km (12 months)

- Remove the middle fairings, fuel tank and outlet pipes. (Refer to page 3-2 and 7-2)

The plug gap is adjusted to 0.6 – 0.8 mm. The gap is correctly adjusted using a thickness gauge. When carbon is deposited on the spark plug, remove the carbon with a spark plug cleaning machine or by carefully using a tool with a pointed end. If electrodes are extremely worn or burnt, replace the plug. Also replace the plug if it has a broken insulator, damaged thread, etc.

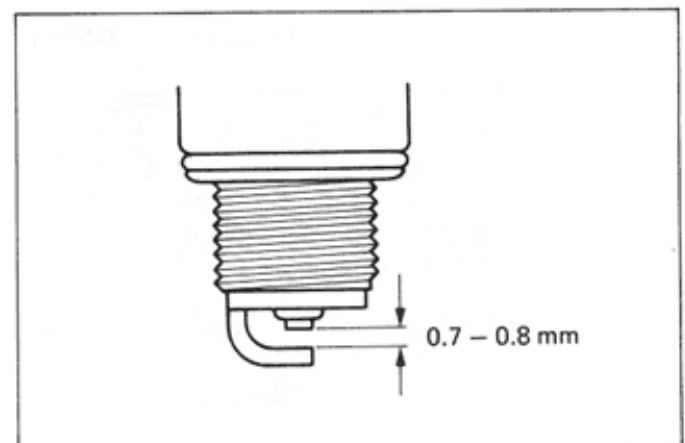
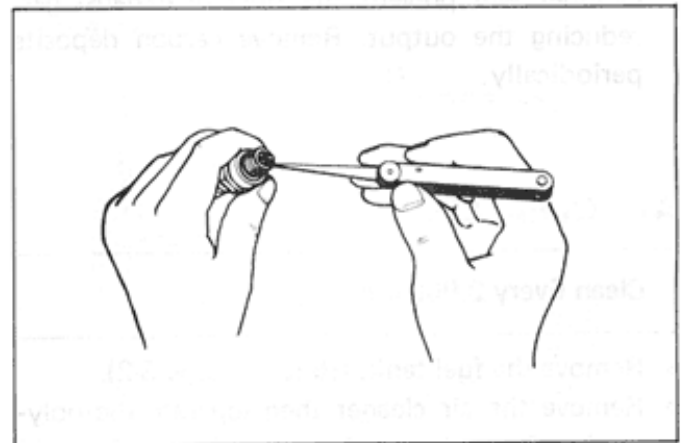

NGK B9ES listed in the table should be used as the standard plug. However, the heat range of the plug should be selected to meet the requirements of speed, actual load, fuel, etc. If the plugs need to be replaced, it is recommended that ones having a heat range closest to the standard plug in the table be selected. Remove the plugs and inspect the insulators. Proper heat range would be indicated if all insulators were light brown in color. If they are blackened by carbon, they should be replaced by a hot type NGK B8ES.

**Recommended spark plug**

	Standard	Hot type
NGK	B9ES (BR9ES)	B8ES (BR8ES)

**NOTE:**

"R" type spark plug is installed for some specifications. "R" type spark plug has a resistor located at the center electrode to prevent radio noise.

**CAUTION:**

Confirm the thread size and reach when replacing the plug. If the reach is too short, carbon will be deposited on the screw portion of the plug hole and engine damage may result.

**CARBURETORS**

Inspect at Initially 1 000 km (2 months) and Every 6 000 km (12 months)

**IDLE RPM ADJUSTMENT**

**NOTE:**

Make this adjustment when the engine is hot.

- Connect a tachometer.
- Start up the engine and set its speed at anywhere between 1 350 and 1 650 r/min by turning the right and left throttle stop screws ① (On Nos. 3 and 4 carburetors)

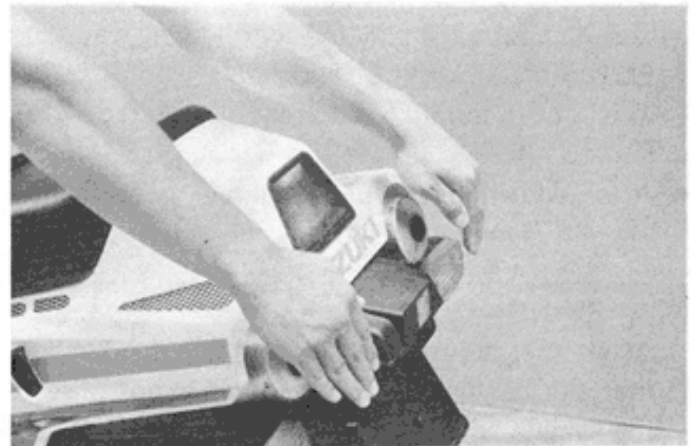

Engine idle speed	1 500 ± 150 r/min
-------------------	-------------------

**CAUTION:**

- \* When setting the idle rpm, always turn the Nos. 3 and 4 carburetor throttle stop screws in the same amount.
- \* Do not touch the Nos. 1 and 2 carburetor throttle stop screws. If you turn these screws, you have to check the balancing carburetors. (Refer to page 5-9)

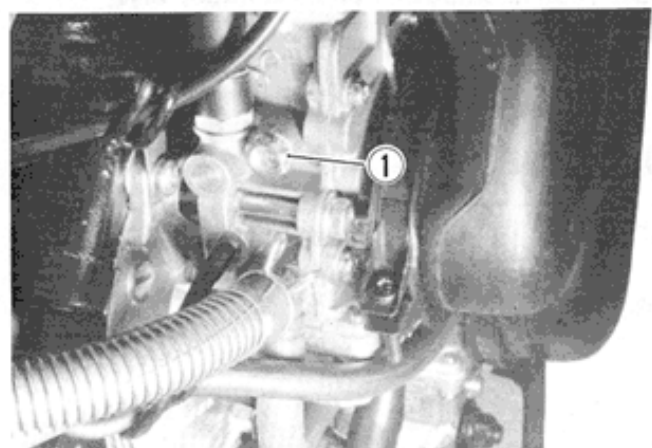

**THROTTLE CABLE**

The throttle cable ① should be adjusted to have a play ② of 0.5 – 1.0 mm.

If the adjustment is necessary, adjust the play in the following way.

- Remove the middle fairings. (Refer to page 7-1)
- Remove the air cleaner outlet pipes. (Refer to page 3-3)
- Loosen the lock nut ③ and turn the adjuster ④ in or out to obtain the correct play ② 0.5 – 1.0 mm.
- After adjusting the cable play, tighten the lock nut ③ and re-check cable play.
- Adjust the other carburetors in the same manner as above.

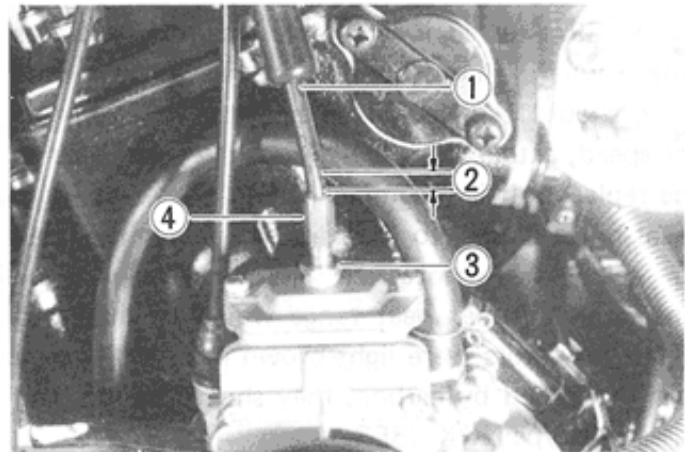

**CAUTION:**

This adjustment could affect the oil pump control cable play, so readjust the oil pump control cable play if necessary.

**CHOKE CABLE**

The choke cable ⑤ should be adjusted to have a play ⑥ of 0.5 – 1.0 mm. If the adjustment is necessary, adjust the play in the following way.

- Loosen the lock nut ⑦ and turn the adjuster ⑧ in or out to obtain the correct play ⑥ 0.5 – 1.0 mm.
- After adjusting the play, tighten the lock nut ⑦ and re-check cable play.

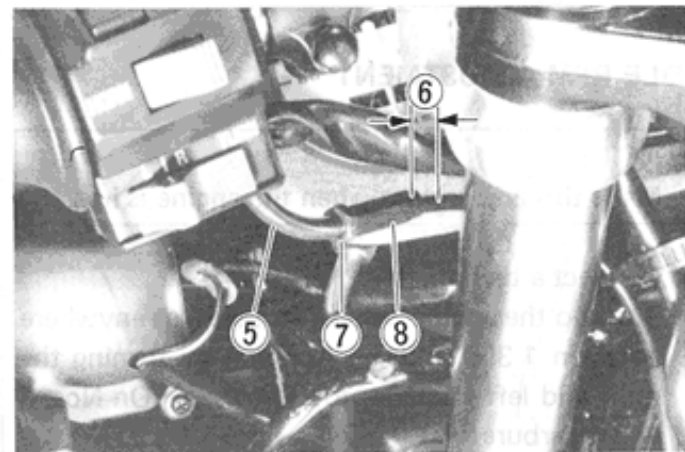

**WARNING:**

After the adjustment is completed, check that the handlebar movement does not raise the engine idle speed and that the throttle grip returns smoothly and automatically.

**FUEL LINES**

Inspect at Initially 1 000 km (2 months) and Every 6 000 km (12 months)  
Replace Every 4 years

## OIL PUMP

Inspect at Initially 1 000 km (2 months) and  
Every 6 000 km (12 months)

The engine oil is fed by the oil pump to the engine. The amount of oil fed to it is regulated by engine speed and the oil pump control lever which is controlled by the amount of throttle opening.

Check the oil pump in the following manner to confirm correct operation for all throttle valve opening positions.

- Remove the left side middle fairing. (Refer to page 7-2)
- Remove the air cleaner outlet pipe. (Refer to page 3-2)
- Turn the throttle grip until the dent mark ① on the No. 3 carburetor throttle valve comes to the upper part on the carburetor main bore.
- Check whether the mark ② on the oil pump control lever is aligned with the index mark ③ when the throttle valve is positioned as above.
- If the marks are not aligned, loosen the lock nut ④ and turn the adjuster ⑤ in or out to align the marks.
- After aligning the marks, tighten the lock nut ④.

### CAUTION:

Oil pump cable adjustment must be done after throttle cable adjustment.

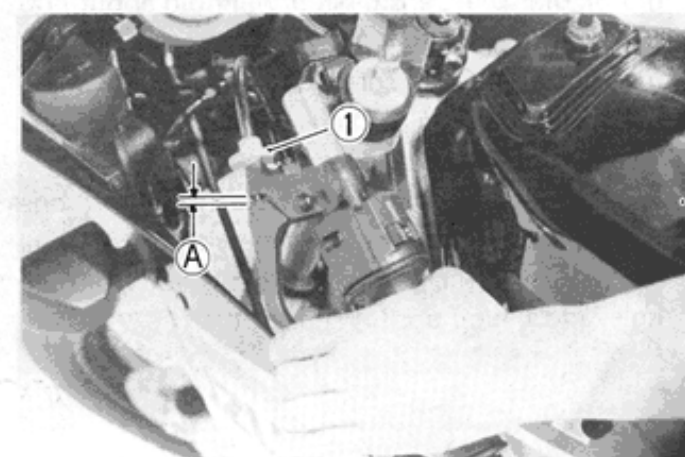
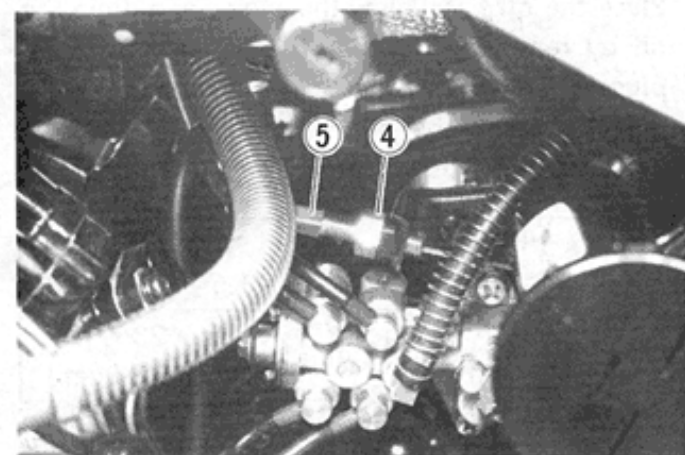
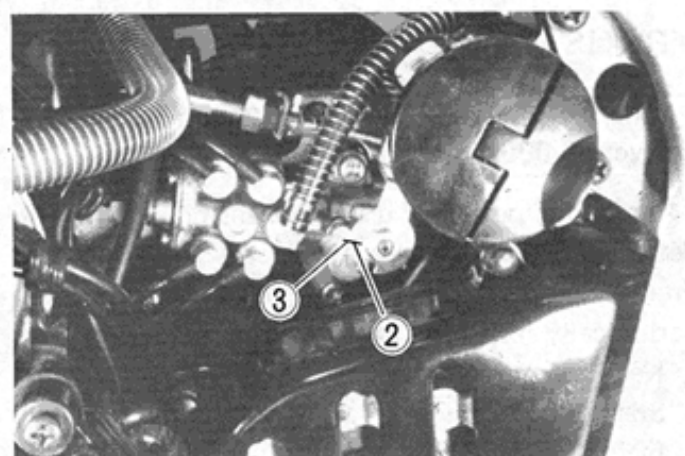
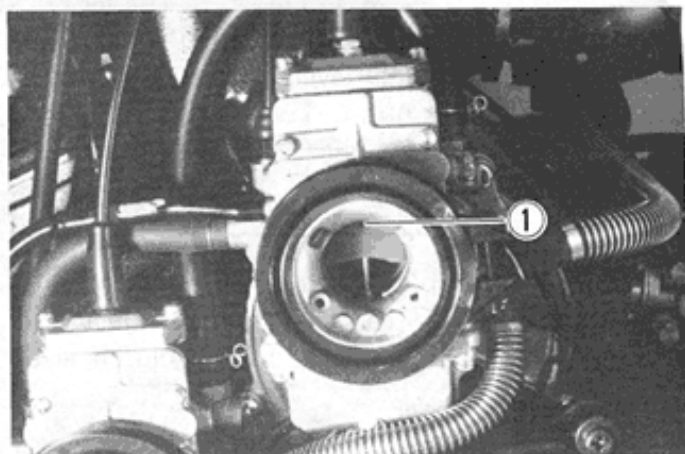

## CLUTCH

Inspect at Initially 1 000 km (2 months) and  
Every 6 000 km (12 months)

- Remove the right middle fairing. (Refer to page 7-2)
- Turn the adjust nut ① fully in on the clutch lever side.
- Loosen the cable lock nut, tighten the adjusting nut to provide play in the outer cable. Adjust

the play of the cable with adjusting nut ② until play ① of the clutch lever is 2 – 3 mm. Next, firmly secure lock nut.

Cable play ①	2 – 3 mm
--------------	----------

- If the specified play can not be obtained with adjusting nut ②, carry out the adjustment using the adjusting nut ① on the clutch lever side.

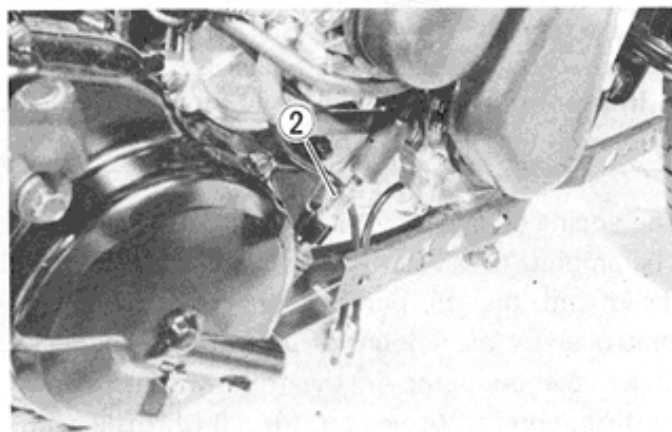

### TRANSMISSION OIL

Change at Initially 1 000 km (2 months) and Every 6 000 km (12 months)
--

After a long period of use, the transmission oil will deteriorate and quicken the wear of sliding and interlocking surfaces. Replace the transmission oil periodically following the procedure below.

- Keep the motorcycle upright.
- Start the engine to warm up the oil, this will facilitate draining of oil. Shut off the engine.
- Place the oil pan below the engine and drain the oil by removing the filler cap ③ and two drain plugs ④ and ⑤.
- After draining the oil completely, fit the two drain plugs ④ and ⑤ securely.

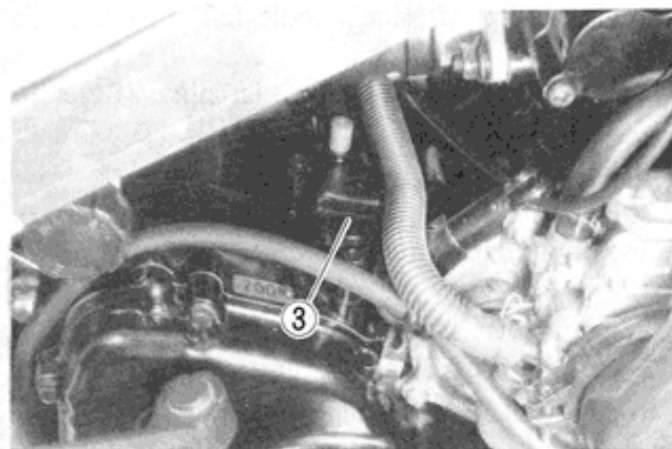

Drain plug tightening torque	10 mm	15 – 20 N·m (1.5 – 2.0 kg·m)
	12 mm	18 – 23 N·m (1.8 – 2.3 kg·m)

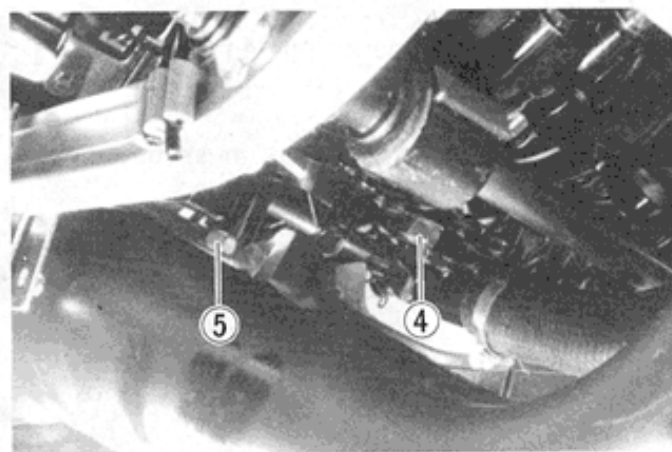

- Add the good quality SAE 20W/40 multi-grade motor oil. The transmission will hold about 800 ml of oil.
- Install the filler cap correctly.
- Start up the engine and allow it to run for several seconds at idling speed.
- Turn off the engine and wait for about one minute, and check the oil level with the oil level screw ⑥. If the oil does not run out from the hole, add the oil until it runs out.

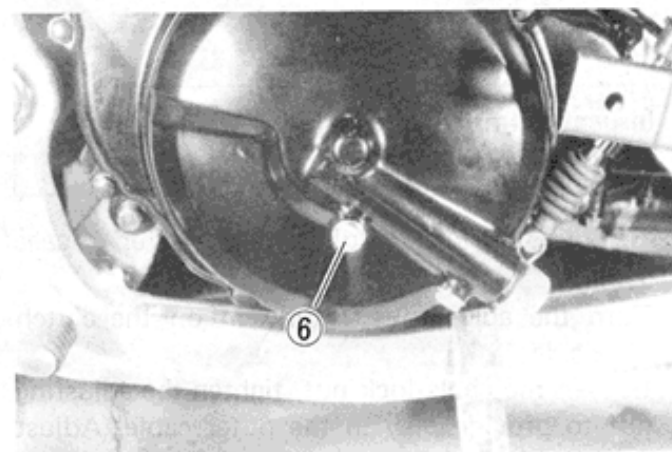

*Golden Spectra 80W Motorcycle Gear Oil*

## COOLING SYSTEM

Inspect at Initially 1 000 km (2 months) and  
Every 12 000 km (24 months)  
Change coolant Every 2 years  
Replace hoses Every 4 years

- Remove the middle and bottom fairings. (Refer to page 7-2)
- Remove the radiator cap ① and drain plug ②.

### WARNING:

Do not open the radiator cap when the engine is hot, as you may be injured by escaping hot liquid or vapor.

### WARNING:

Coolant may be harmful if swallowed or if it comes in contact with skin or eyes. If coolant gets into the eyes or in contact with the skin, it should be flushed thoroughly with plenty of water. If swallowed, induce vomiting and call physician immediately!

- Flush the radiator with fresh water.
- Tighten the drain plug ② securely.
- Install the specified coolant upto the radiator inlet hole.

### NOTE:

For coolant information, refer to "COOLING SYSTEM" section page 4-2.

- Fill the reservoir tank to the "U" level with coolant.
- Close the radiator cap securely.
- After warming up and cooling down the engine, check the coolant level of the reservoir tank and install the coolant to the "U" level if the level is below "L".

2250 ml including reservoir tank

250 ml reservoir tank

- Add 2 packs of anti-leakage material (Bar's leaks) in the coolant.

99000-24240

Bar's leak

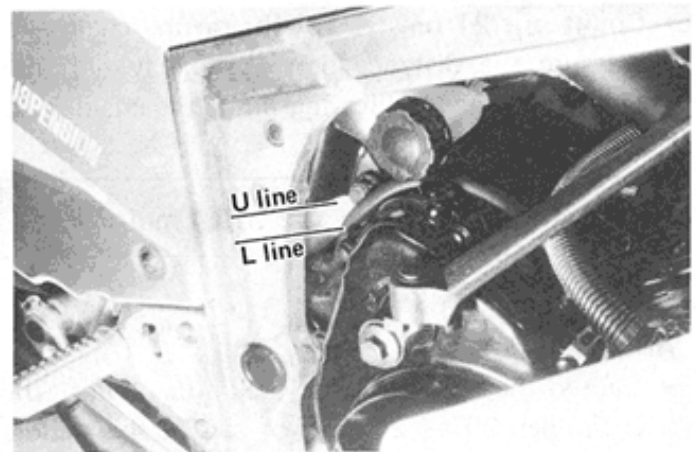
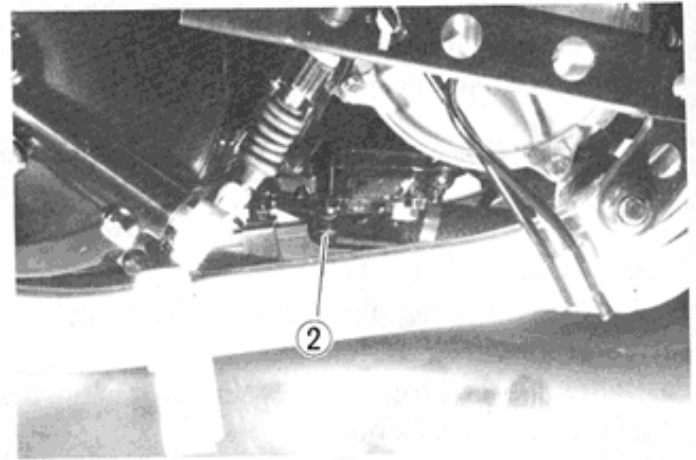
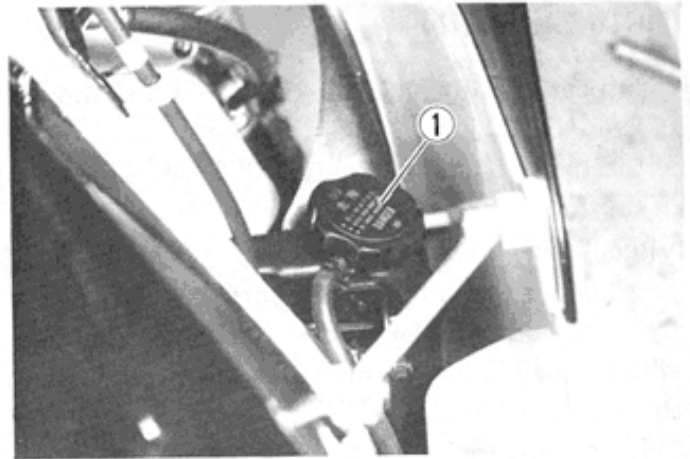

## DRIVE CHAIN

Inspect at Initially 1 000 km (2 months) and  
Every 6 000 km (12 months)  
Clean and Lubricate Every 1 000 km

Visually check the drive chain for the below-listed possible malconditions. (Support the motorcycle by jack and wooden block, and turn the rear wheel slowly by hand with the transmission shifted to Neutral.)

- \* Loose pins
- \* Excessive wear
- \* Damaged rollers
- \* Improper chain adjustment
- \* Dry or rusted links
- \* Missing O-ring seals
- \* Kinked or binding links

If any defects are found, the drive chain must be replaced.

### CHECKING

- Remove the cotter pin. (Canada model only)
- Loosen axle nut ①.
- Tense the drive chain fully by tightening the chain adjuster lock nuts ②.
- Count out 21 pins (20-pitch) on the chain and measure the distance between the two. If the distance exceeds following limit, the chain must be replaced.

Service Limit	319.4 mm
---------------	----------

### ADJUSTING

- Loosen the chain adjuster lock nuts ② until the chain has 20 – 25 mm of sag at the middle between engine and rear sprockets. The mark ③ on both chain adjusters must be at the same position on the scale to ensure that the front and rear wheels are correctly aligned. Place the motorcycle on the side stand for accurate adjustment.
- After adjusting the drive chain, tighten the axle nut ① securely.
- Tighten the chain adjuster lock nuts securely.

Rear axle nut tightening torque	50 – 80 N·m (5.0 – 8.0 kg·m)
---------------------------------	---------------------------------

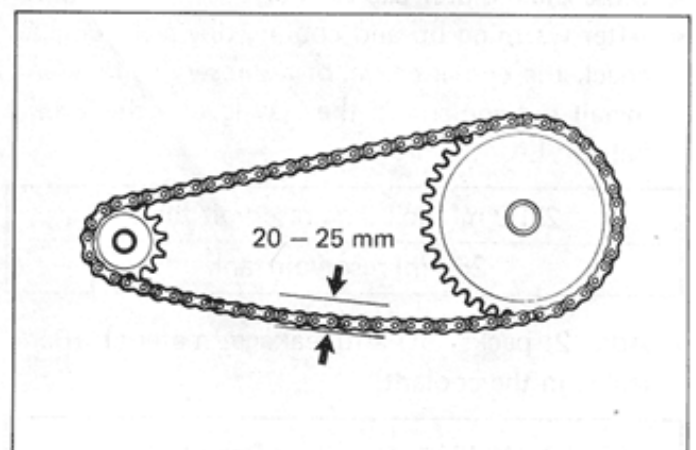
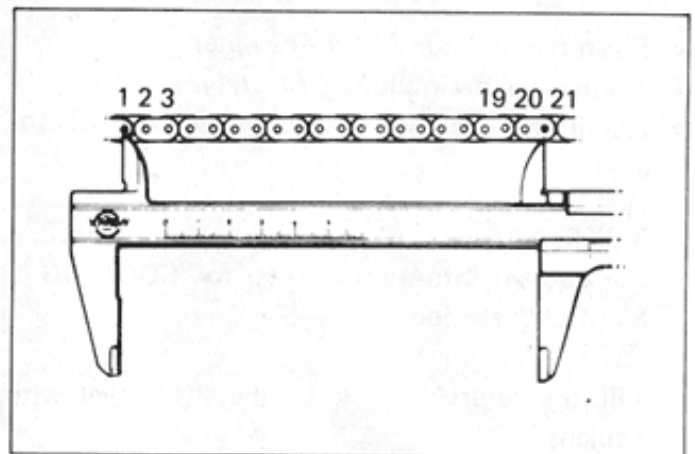
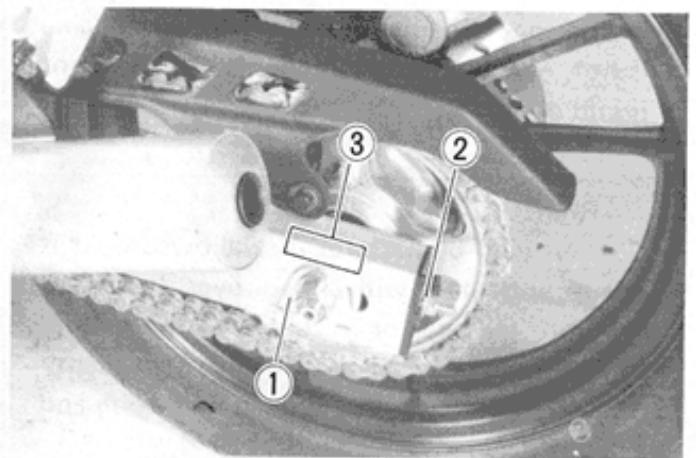
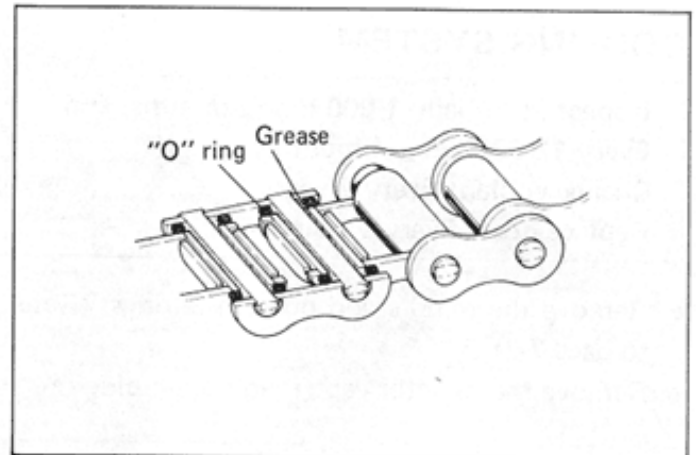

### CLEANING AND LUBRICATING

- Wash the chain with kerosene. If the chain tends to rust faster, the intervals must be shortened.

**CAUTION:**

Do not use trichlene, gasoline or any similar fluids: These fluids have too great a dissolving power for this chain and, what is more important, can spoil the "O" rings (or seals) confining the grease in the bush to pin clearance. Remember, high durability comes from the presence of grease in that clearance.

- After washing and drying the chain, oil it with a heavy-weight motor oil.

**CAUTION:**

Do not use any oil sold commercially as "drive chain oil". Such oil too can spoil the "O" rings (or seals).

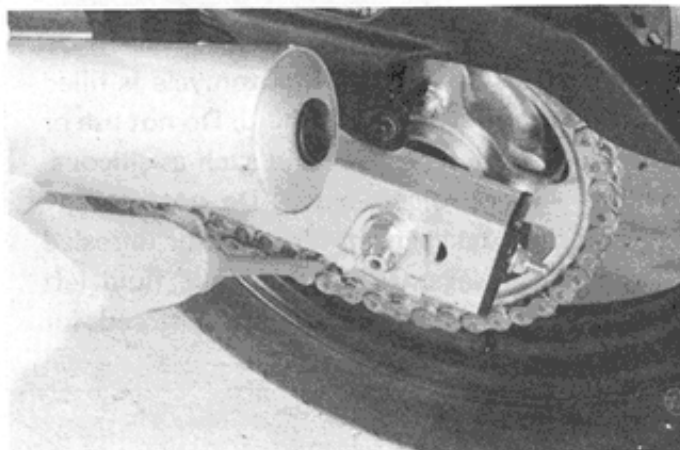

**CAUTION:**

The standard drive chain is DAIDO DID 50VA or TAKASAGO RK50HFO. SUZUKI recommends that the above-mentioned standard drive chain be used for the replacement.

### BRAKES

Inspect at Initially 1 000 km (2 months) and  
Every 6 000 km (12 months)  
Replace hoses Every 4 years  
Replace fluid Every 2 years

#### BRAKE FLUID LEVEL

- Keep the motorcycle upright and place the handlebars straight.
- Remove the right frame cover.
- Check the brake fluid level by observing the upper (only for rear brake) and lower (both front and rear brake) limit lines on the brake fluid reservoirs.
- When the level is below the lower limit line, replenish with brake fluid that meets the following specification.

Specification  
and Classification

SAE J1703,  
DOT3 or DOT4

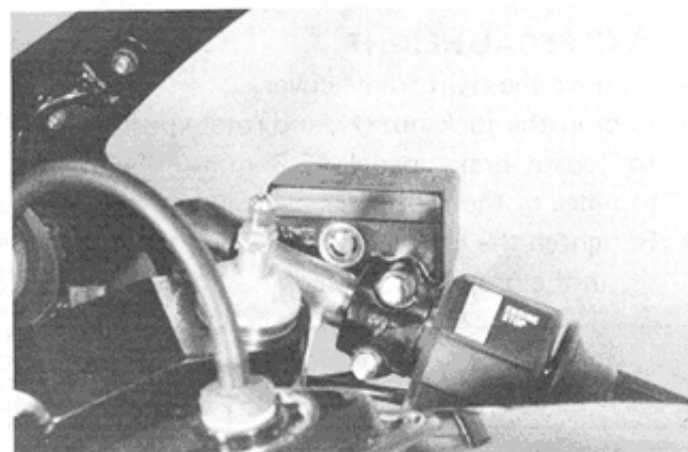

**WARNING:**

The brake system of this motorcycle is filled with a glycol-based brake fluid. Do not use or mix different types of fluid such as silicone-based and petroleum-based. Do not use any brake fluid taken from old, used or unsealed containers. Never re-use the brake fluid left over from the last servicing and stored for long periods.

**WARNING:**

Brake fluid, if it leaks, will interfere with safe running and immediately discolor painted surfaces. Check the brake hoses for cracks and hose joints for leakage before riding.

**BRAKE PADS**

Wearing condition of brake pads can be checked by observing the limit line ① marked on the pad. When the wear exceeds the limit line, replace the pads with new ones. (Refer to page 7-9 and 7-29)

**BRAKE PEDAL HEIGHT**

- Remove the right frame cover.
- Loosen the lock nut ②, and rotate push rod ③ to locate brake pedal 47.5 mm (A) below the top face of the footrest.
- Retighten the lock nut ② to secure the push rod ③ in the proper position.

Brake pedal height (A)	47.5 mm
------------------------	---------

**BRAKE LIGHT SWITCHES**

Adjust both brake light switches, front and rear, so that brake light will come on just before a pressure is felt when the brake lever is squeezed, or the brake pedal is depressed.

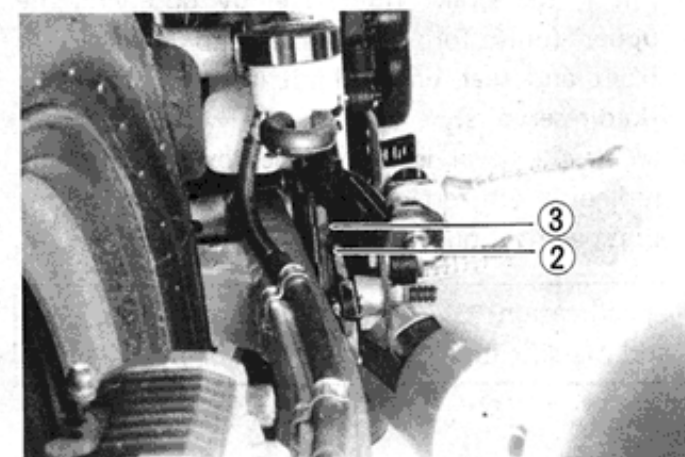
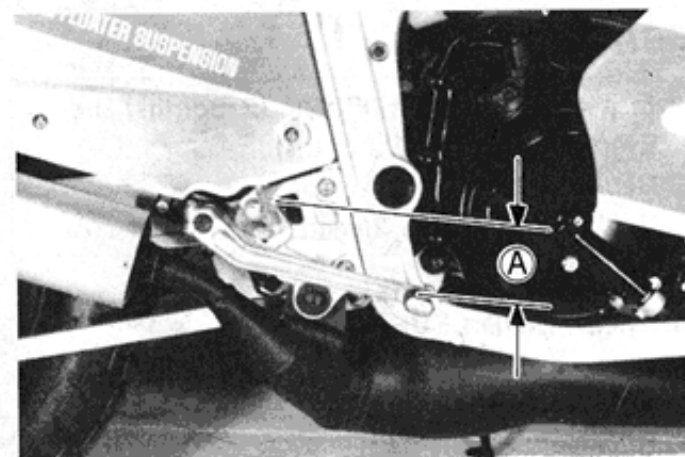
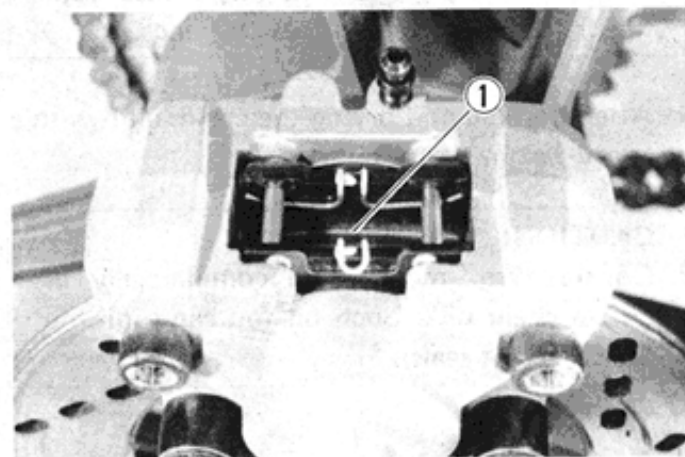

### BLEEDING AIR FROM THE BRAKE FLUID CIRCUIT

Air trapped in the fluid circuit acts like a cushion to absorb a large proportion of the pressure developed by the master cylinder and thus interferes with the full braking performance of the brake caliper. The presence of air is indicated by "sponginess" of the brake lever and also by lack of braking force. Considering the danger to which such trapped air exposes the machine and rider, it is essential that, after remounting the brake and restoring the brake system to the normal condition, the brake fluid circuit be purged of air in the following manner:

- Fill up the master cylinder reservoir to the upper end of the inspection window (for front brake) and upper line (for rear brake). Replace the reservoir cap to prevent entry of dirt.
- Attach a pipe to the caliper bleeder valve, and insert the free end of the pipe into a receptacle.
- Front brake: Bleed the air from the inboard valve first, and then outboard valve.

**NOTE:**

When bleeding the air, always start with the left side.

- Squeeze and release the brake lever several times in rapid succession, and squeeze the lever fully without releasing it. Loosen the bleeder valve by turning it a quarter of a turn so that the brake fluid runs into the receptacle; this will remove the tension of the brake lever causing it to touch the handlebar grip. Then, close the valve, pump and squeeze the lever, and open the valve. Repeat this process until the fluid flowing into the receptacle no longer contains air bubbles.

**NOTE:**

Replenish the brake fluid reservoir as necessary while bleeding the brake system. Make sure that there is always some fluid visible in the reservoir.

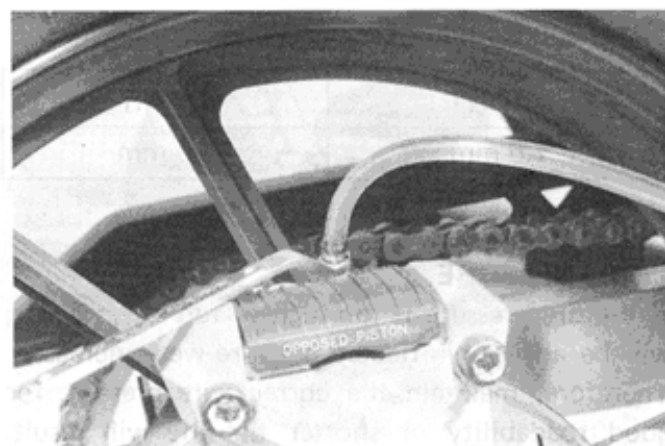
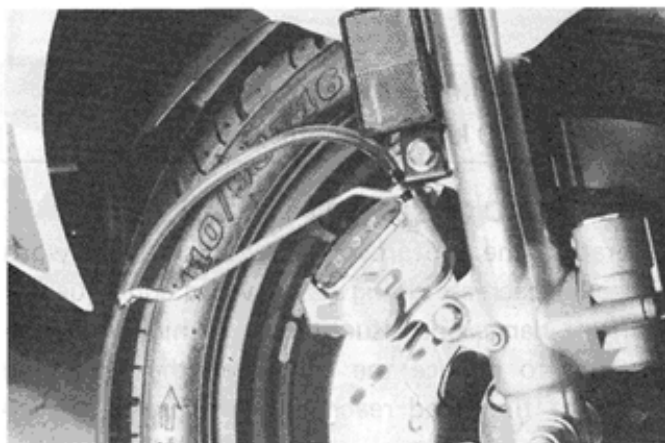

- Close the bleeder valve, and disconnect the pipe. Fill the reservoir to the upper end of the inspection window (for front brake) and upper line (for rear brake).
- Rear brake: Differences between front and rear are that the master cylinder is actuated by a pedal.

Bleeder valve tightening torque	6 – 9 N·m (0.6 – 0.9 kg-m)
---------------------------------	-------------------------------

**CAUTION:**

Handle the brake fluid with care: the fluid reacts chemically with paint, plastics, rubber materials, etc.

**TIRES**

Inspect at Initially 1 000 km (2 months) and Every 6 000 km (12 months)

**TIRE TREAD CONDITION**

Operating the motorcycle with excessively worn tires will decrease riding stability and consequently invite a dangerous situation. It is highly recommended to replace the tire when the remaining depth of tire tread reaches the following specifications.

**Tire tread depth limit**

FRONT	REAR
1.6 mm	2.0 mm

**TIRE PRESSURE**

If the tire pressure is too high or too low, steering will be adversely affected and tire wear increased. Therefore, maintain the correct tire pressure for good roadability or shorter tire life will result. Cold inflation tire pressure is as follows.

	Solo riding		Dual riding	
	kg/cm <sup>2</sup>	kPa	kg/cm <sup>2</sup>	kPa
FRONT	2.25	225	2.25	225
REAR	2.50	250	2.90	290

**CAUTION:**  
 The standard tire fitted on this motorcycle is 110/90V16 for front and 120/90V17 for rear. The use of a tire other than the standard may cause instability. It is highly recommended to use a SUZUKI Genuine Tire.

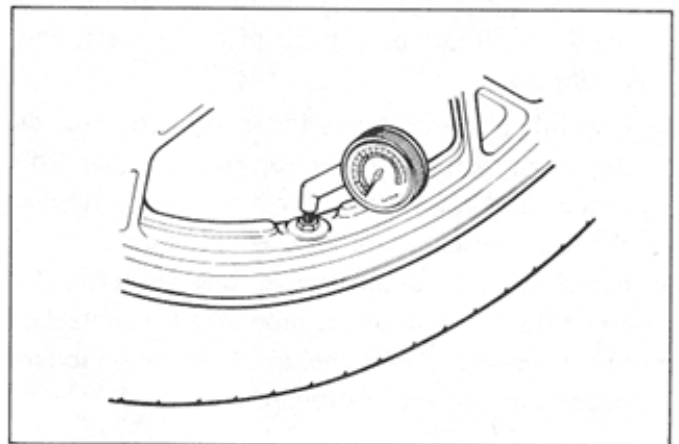
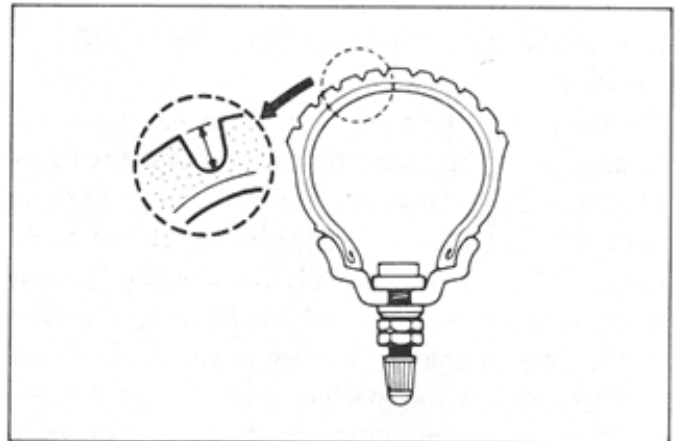

## STEERING

Inspect at Initially 1 000 km (2 months) and  
Every 6 000 km (12 months)

Taper roller type bearings are applied on the steering system for better handling.

Steering should be adjusted properly for smooth turning of handlebars and safe running. Too stiff steering prevents smooth turning of handlebars and too loose steering will cause poor stability.

Check that there is no play in the front fork assembly by supporting the machine so that the front wheel is off the ground, with wheel straight ahead, grasp lower fork tubes near the axle and pull forward. If play is found, perform steering bearing adjustment. (Refer to page 7-28).

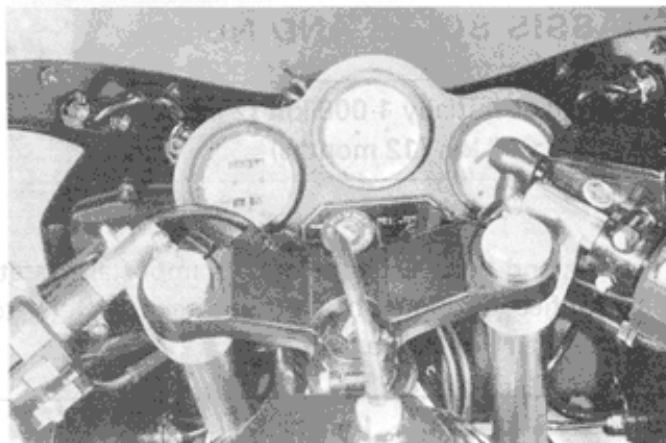

## FRONT FORK

Inspect Every 12 000 km (24 months)  
Inspect air pressure Every 6 months

- Inspect the front forks for oil leakage, scoring and scratches on the outer surface of the inner tubes.  
Replace any defective parts, if necessary.  
(Refer to page 7-16).
- Keep the front wheel off the ground.
- Remove the air valve caps and press the air valve to equalize the fork air pressure with atmospheric pressure. This must be done when the forks are cold. (Refer to page 7-23 for adjusting front fork.)

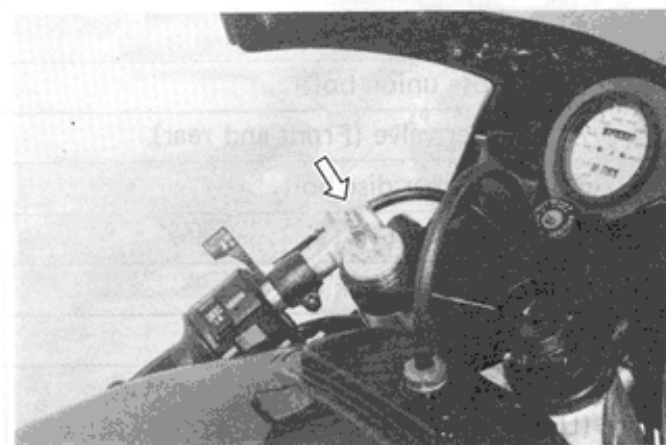
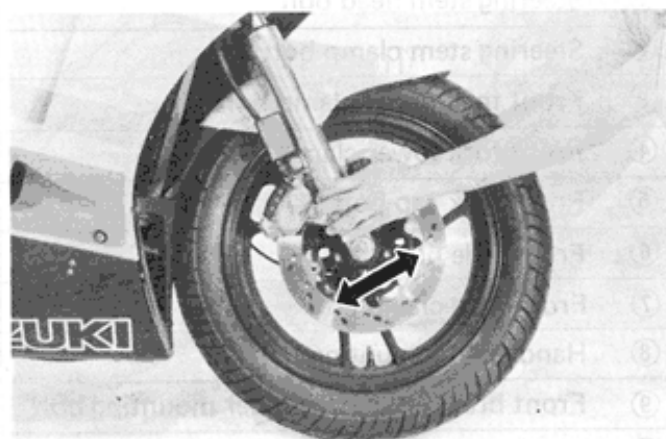

Front fork air pressure (Standard)	0 kPa (0 kg/cm <sup>2</sup> )
------------------------------------	-------------------------------

### CAUTION:

The maximum permissible air pressure is 250 kPa (2.5 kg/cm<sup>2</sup>), to avoid fork oil seal and valve damage.

## REAR SUSPENSION

Inspect Every 12 000 km (24 months)

Inspect the rear shock absorber for oil leakage and check that there is no play in the swingarm assembly.

## CHASSIS BOLTS AND NUTS

Tighten at Initially 1 000 km (2 months) and  
Every 6 000 km (12 months)

The nuts and bolts listed below are important safety parts. They must be retightened when necessary to the specified torque with a torque wrench. (Refer to page 2-18 for the locations of the following nuts and bolts on the motorcycle.)

Item	N·m	kg·m
① Steering stem head bolt	20 – 30	2.0 – 3.0
② Steering stem clamp bolt	15 – 25	1.5 – 2.5
③ Front fork upper clamp bolt	20 – 30	2.0 – 3.0
④ Front fork lower clamp bolt	20 – 30	2.0 – 3.0
⑤ Front fork cap bolt	25 – 35	2.5 – 3.5
⑥ Front axle nut	36 – 52	3.6 – 5.2
⑦ Front axle clamp nut	15 – 25	1.5 – 2.5
⑧ Handlebars mounting bolt	50 – 60	5.0 – 6.0
⑨ Front brake master cylinder mounting bolt	5 – 8	0.5 – 0.8
⑩ Front caliper mounting bolt	15 – 25	1.5 – 2.5
⑪ Front caliper housing bolt	30 – 36	3.0 – 3.6
⑫ Brake hose union bolt	20 – 25	2.0 – 2.5
⑬ Air bleeder valve (Front and rear)	6 – 9	0.6 – 0.9
⑭ Front and rear disc bolt	15 – 20	1.5 – 2.0
⑮ Swingarm pivot nut	50 – 80	5.0 – 8.0
⑯ Rear brake rod lock nut	15 – 25	1.5 – 2.5
⑰ Rear brake pedal bolt	6 – 10	0.6 – 1.0
⑱ Rear shock absorber mounting nut (Upper and lower)	48 – 72	4.8 – 7.2
⑲ Rear cushion lever nut	48 – 72	4.8 – 7.2
⑳ Rear cushion rod nut (Upper and lower)	48 – 72	4.8 – 7.2
㉑ Rear caliper mounting bolt	15 – 25	1.5 – 2.5
㉒ Rear caliper housing bolt	28 – 32	2.8 – 3.2
㉓ Rear torque link nut (Front and rear)	10 – 15	1.0 – 1.5
㉔ Rear master cylinder mounting bolt	5 – 8	0.5 – 0.8
㉕ Rear axle nut	50 – 80	5.8 – 8.0
㉖ Rear sprocket nut	48 – 72	4.8 – 7.2

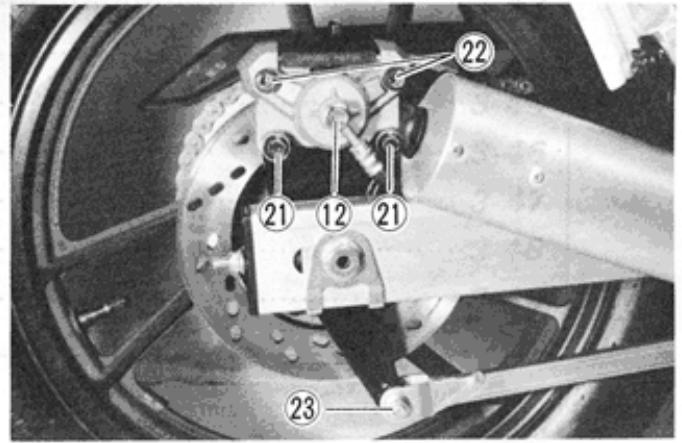
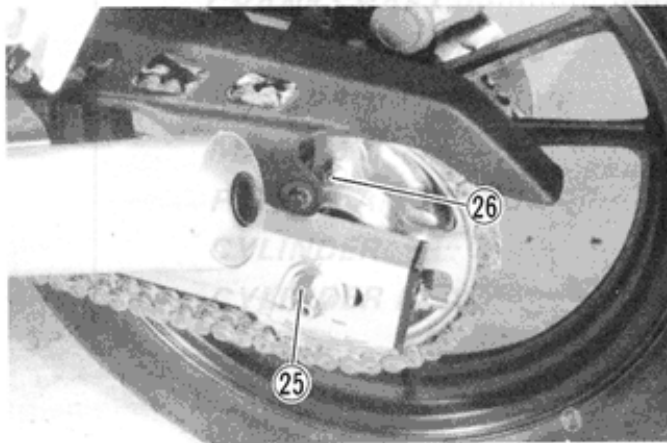
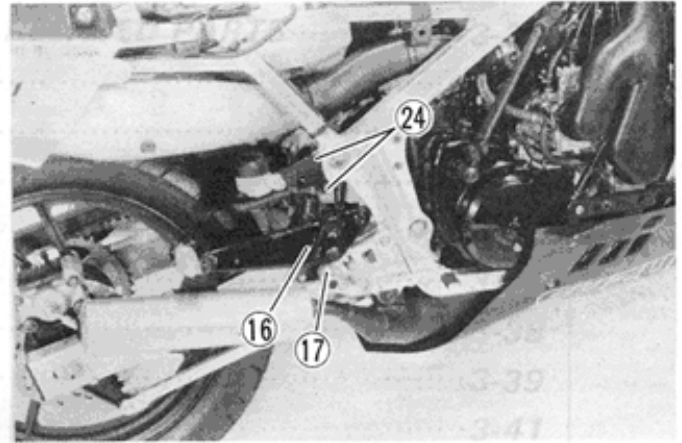
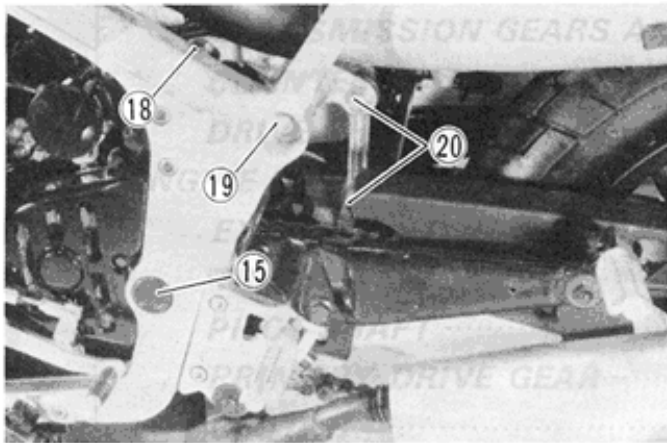
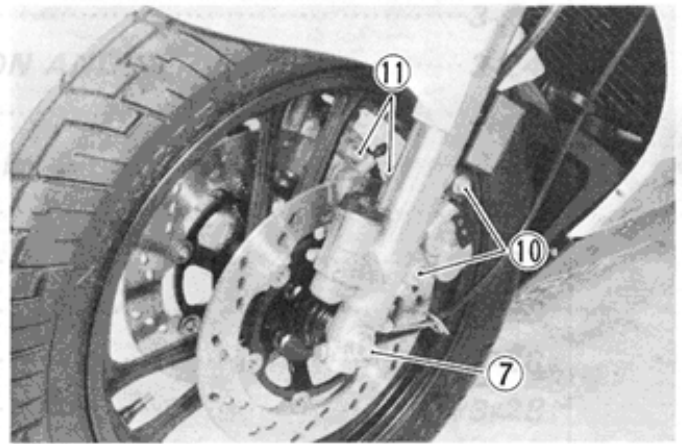
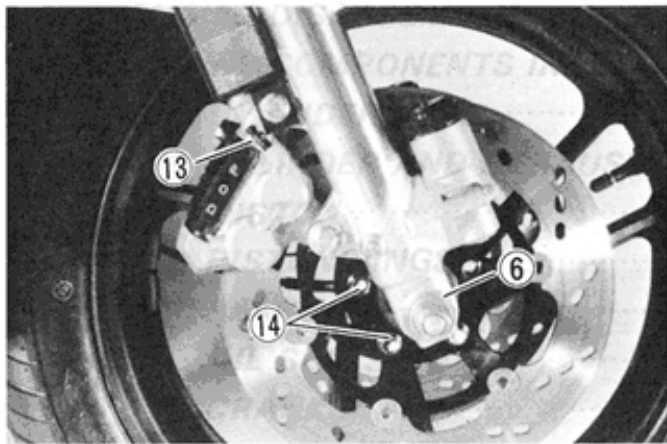
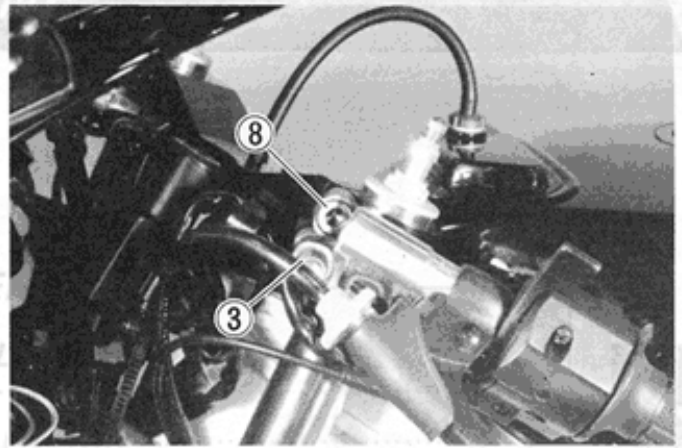
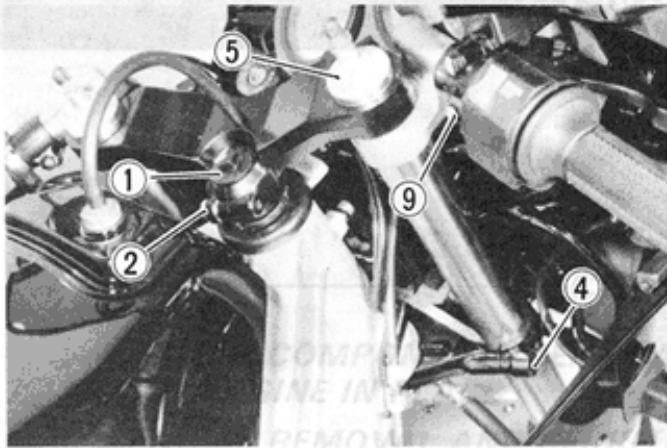

# ENGINE

## CONTENTS

<b>ENGINE COMPONENTS REMOVABLE WITH THE ENGINE IN PLACE</b> .....	<b>3- 1</b>
<b>ENGINE REMOVAL AND REINSTALLATION</b> .....	<b>3- 2</b>
<b>ENGINE DISASSEMBLY</b> .....	<b>3-11</b>
<b>ENGINE COMPONENTS INSPECTION AND SERVICING</b> .....	<b>3-24</b>
<b>CYLINDER HEAD</b> .....	<b>3-24</b>
<b>CYLINDER AND EXHAUST VALVE</b> .....	<b>3-24</b>
<b>PISTON</b> .....	<b>3-25</b>
<b>PISTON RINGS</b> .....	<b>3-27</b>
<b>BEARINGS</b> .....	<b>3-28</b>
<b>OIL SEALS</b> .....	<b>3-28</b>
<b>CRANKSHAFT</b> .....	<b>3-28</b>
<b>CLUTCH PLATES</b> .....	<b>3-29</b>
<b>TRANSMISSION GEARS AND RELATED PARTS</b> .....	<b>3-31</b>
<b>COUNTERSHAFT</b> .....	<b>3-32</b>
<b>DRIVE SHAFT</b> .....	<b>3-33</b>
<b>ENGINE REASSEMBLY</b> .....	<b>3-35</b>
<b>EXHAUST VALVE</b> .....	<b>3-35</b>
<b>TRANSMISSION</b> .....	<b>3-36</b>
<b>PILOT SHAFT</b> .....	<b>3-38</b>
<b>PRIMARY DRIVE GEAR</b> .....	<b>3-39</b>
<b>CLUTCH</b> .....	<b>3-41</b>
<b>CRANKSHAFT</b> .....	<b>3-43</b>
<b>UPPER CRANKCASE</b> .....	<b>3-44</b>
<b>ROTARY DISC VALVE</b> .....	<b>3-44</b>
<b>MAGNETO</b> .....	<b>3-46</b>
<b>PISTON AND RINGS</b> .....	<b>3-47</b>
<b>CYLINDER</b> .....	<b>3-48</b>
<b>CYLINDER HEAD</b> .....	<b>3-49</b>

# ENGINE COMPONENTS REMOVABLE WITH THE ENGINE IN PLACE

The parts listed below can be removed and reinstalled without removing the engine from the frame. Refer to the page listed in the section for removal and reinstallation instructions.

ENGINE LEFT SIDE	See page	ENGINE CENTER	See page	ENGINE RIGHT SIDE	See page
• Gearshift lever .....	3-5	• Radiator .....	3-3	• Carburetors .....	3-3
• Engine sprocket cover .....	3-6	• Muffler .....	3-4	• Rotary disc valve outer seat, rotary disc valve and inner seat .....	3-13
• Engine sprocket and drive chain .....	3-6	• Cylinder head .....	3-11	• Clutch cover .....	3-15
• Oil pump .....	3-17	• Thermostat .....	3-11	• Clutch .....	3-15
• Carburetors .....	3-3	• Water Temp. gauge .....	3-11	• Primary drive and driven gears .....	3-16
• Magneto cover and magneto rotor .....	3-12	• Cylinder and exhaust valve .....	3-12	• Gearshift shaft .....	3-16
• Magneto stator .....	3-13	• Piston .....	3-12	• Transmission assembly .....	3-17
• Rotary disc valve outer seat, rotary disc valve and inner seat .....	3-13	• Upper crankcase .....	3-14		
• Pick-up coil .....	3-18	• Crankshafts .....	3-15		
• Neutral indicator switch .....	3-17	• Oil pan .....	3-19		
		• Water pump and its drive gear .....	3-19		
		• Pilot shaft .....	3-19		

## ENGINE REMOVAL AND REINSTALLATION

### ENGINE REMOVAL

Before taking the engine out of the frame, wash the engine with a steam cleaner, and drain transmission oil and cooling solution etc. The procedure of engine removal is sequentially explained in the following steps, and engine installation is effected by reversing the removal procedure.

- Remove the middle and lower fairings. (Refer to page 7-2.)
- Remove the seat and frame covers.

#### NOTE:

To prevent damage to the frame cover, the seat must be removed before frame cover is detached.

- Remove the pillion seat and tail cover.
- Turn the fuel cock to the OFF position and remove the fuel cock.
- Shift the hose clip sideways and disconnect the two fuel hose from Nos. 3 and 4 carburetors.
- Release the lock with ignition key ① and dismount the fuel tank from the frame.
- Place an oil pan under the engine and remove the oil drain plugs and filler plug to drain out transmission oil.
- Remove the radiator cap and drain plug, and drain cooling solution completely.

② Transmission oil drain plugs

③ Coolant drain plug

#### Tightening torque

		N·m	kg·m
Transmission	10 mm	15 - 20	1.5 - 2.0
oil drain plug	12 mm	18 - 23	1.8 - 2.3
Coolant drain plug		4 - 7	0.4 - 0.7

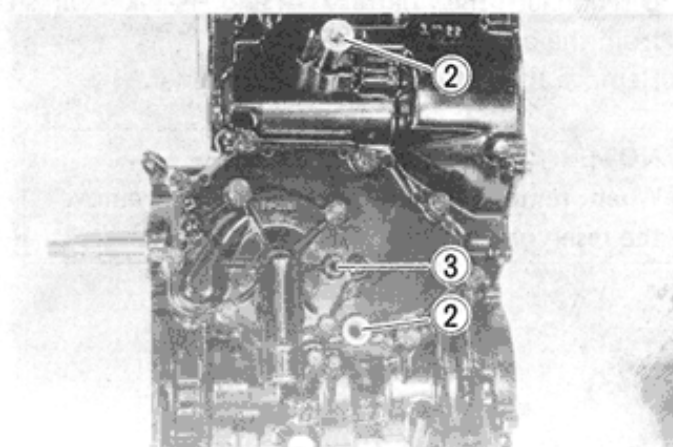
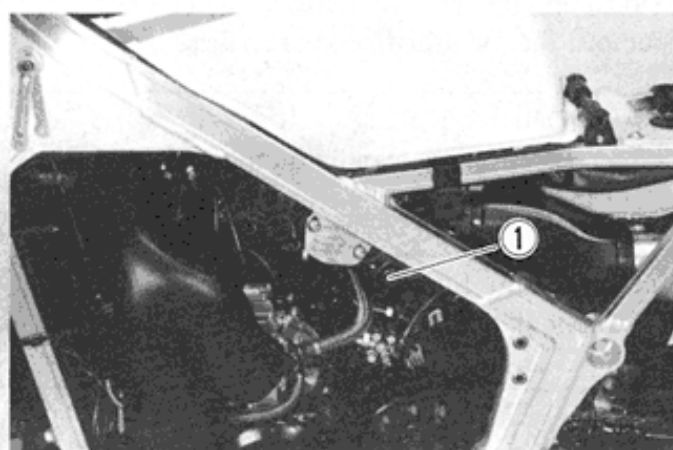
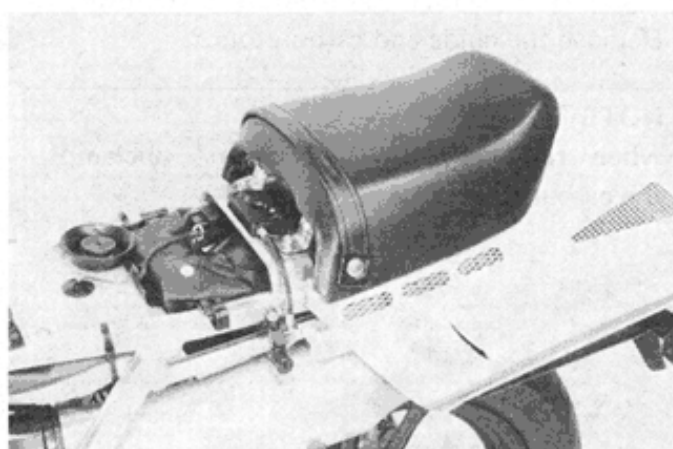

- Loosen the clamp screws and remove the air cleaner outlet pipe.

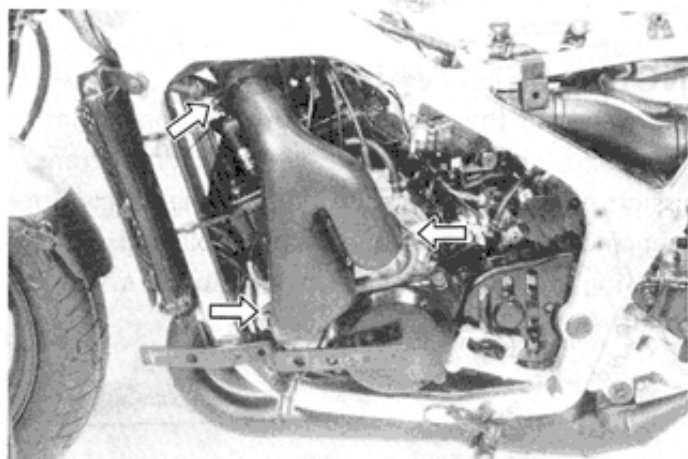

- Disconnect the oil hoses from the carburetors.
- Remove the guide and carburetors.

**NOTE:**

When removing the carburetors, unclamp the carburetor vent hose ①.

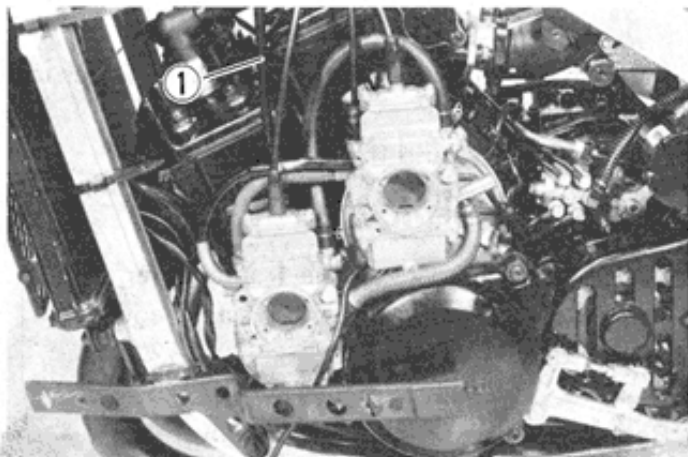

- Unclamp the radiator hoses at engine side and remove the radiator from the chassis.

**CAUTION:**

When loosening the radiator mounting nuts, hold the damper with open end wrench.

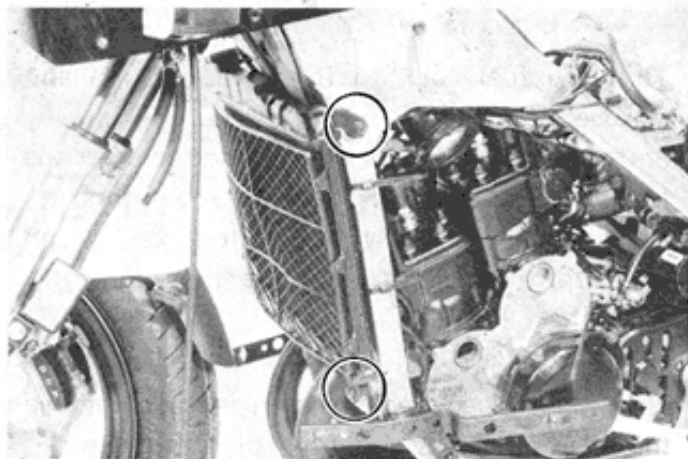

Radiator mounting nut tightening torque	7 – 9 N·m (0.7 – 0.9 kg-m)
---	-------------------------------

- Disconnect the battery ⊖ and ⊕ lead wires from the battery terminals.
- Remove the battery and battery holder.

**NOTE:**

When removing the battery holder, remove the reservoir tank securing screw.

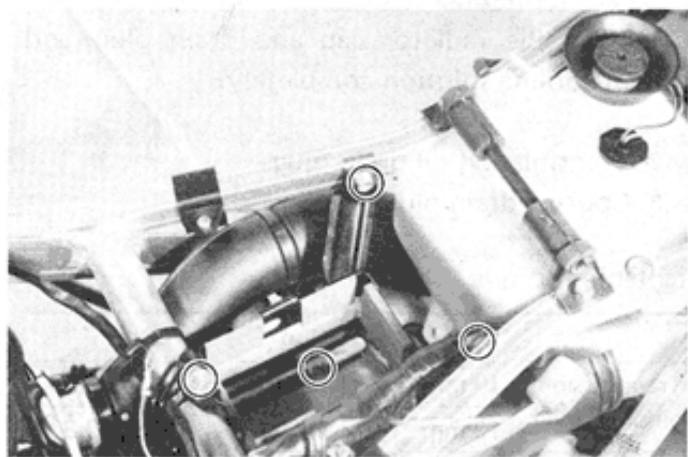

- Disconnect the spark plug caps from the spark plugs.
- Remove the exhaust pipe and muffler assembly.

**NOTE:**

When reinstalling the mufflers, always use a new exhaust pipe gasket.

**Tightening torque**

	N·m	kg·m
Exhaust pipe clamp bolt or nut	24 – 28	2.4 – 2.8
Muffler mounting bolt	21 – 25	2.1 – 2.5

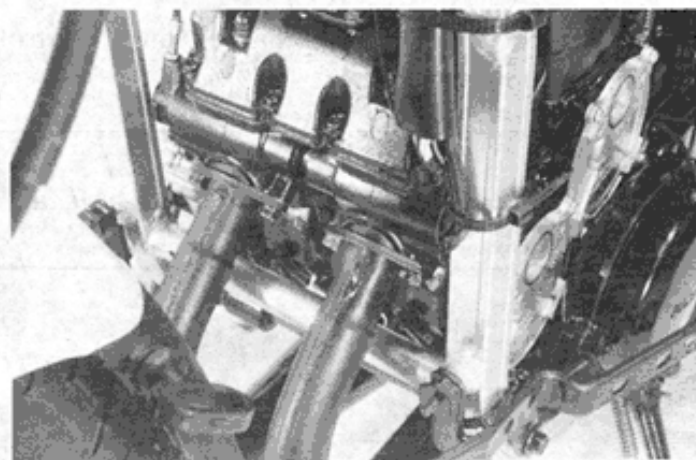
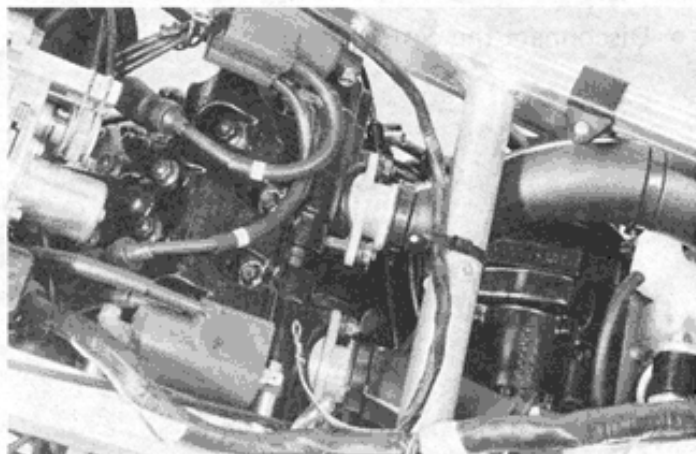

- Loosen the clamps and disconnect the following lead wires.

- ① Neutral indicator switch lead
- ② Magneto lead
- ③ Water temp. gauge lead
- ④ Pick-up coil lead

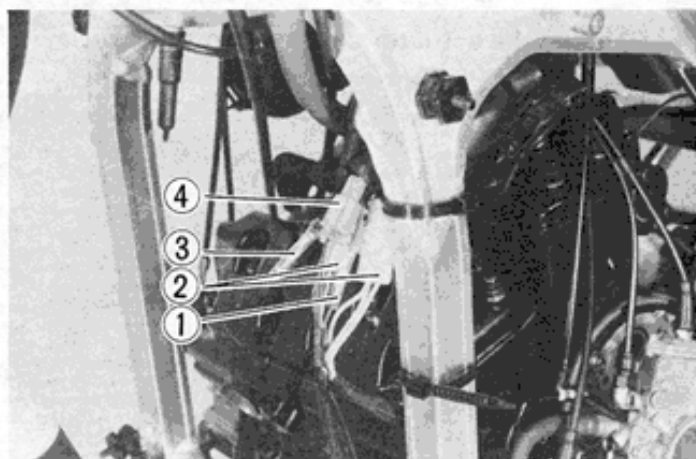

- Remove the rear shock absorber adjuster ⑤.
- Disconnect the oil hose ⑥ from the oil tank.
- Disconnect the oil pump control cable.

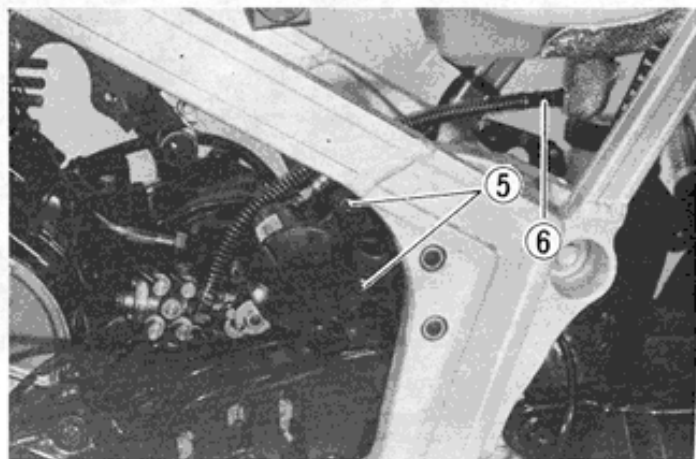

- Disconnect the clutch cable ①.

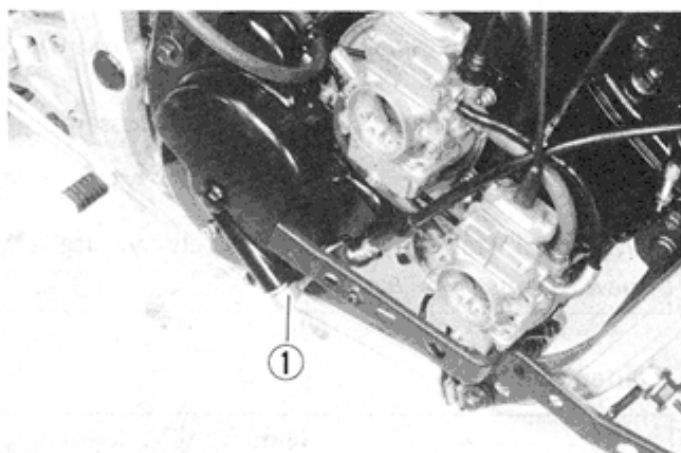

- Disconnect the four exhaust valve control cables from the actuator.

**NOTE:**

Turn the control cable adjusters to have a cable play.



- Remove the actuator and two ignition coils.

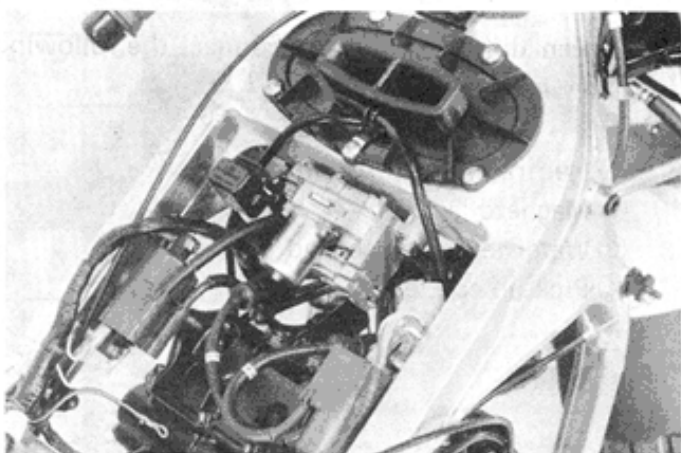

- Remove the gearshift lever.

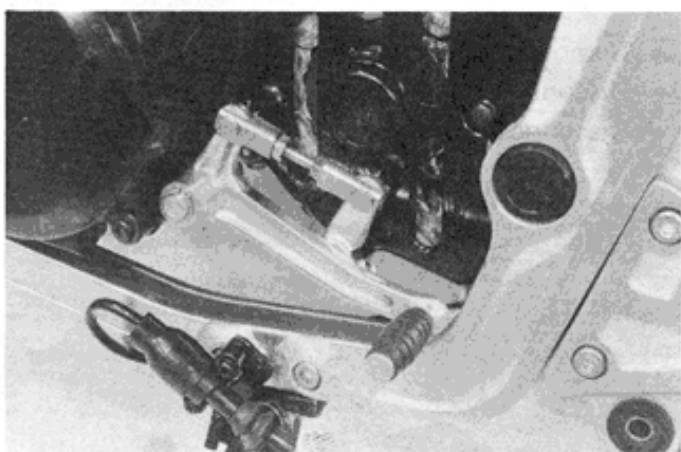

- Remove the engine sprocket cover.
- Flatten the lock washer and loosen the engine sprocket nut while applying the rear brake.

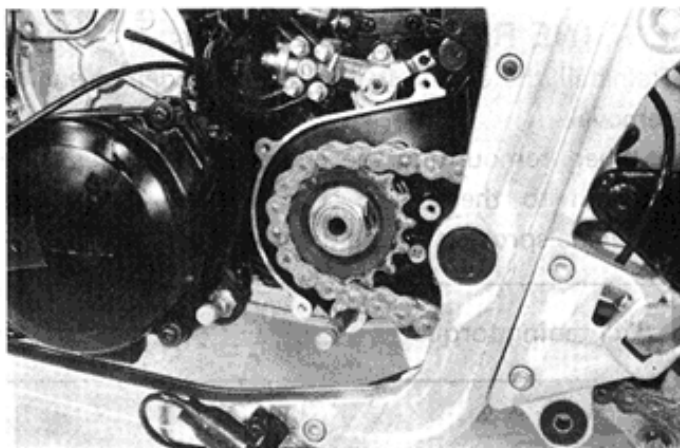

- Loosen the rear axle nut and drive chain adjusters.
- Push the rear wheel forward or remove the rear wheel, and disengage the drive chain from the rear sprocket.
- Disengage the drive chain from the engine sprocket, and remove the engine sprocket.

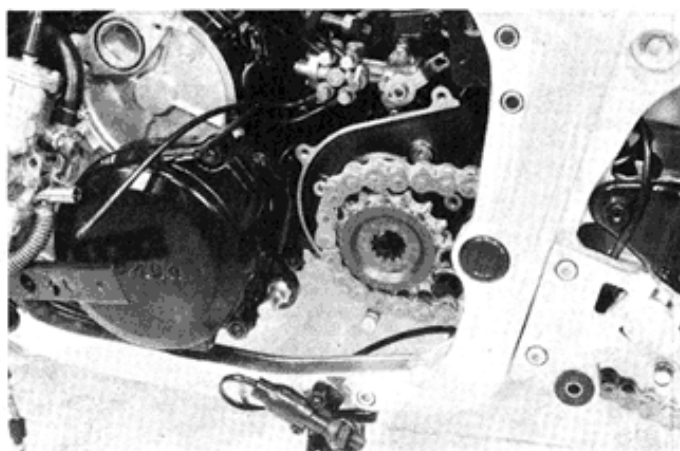

- Remove the engine mounting brackets and three engine mounting bolts.

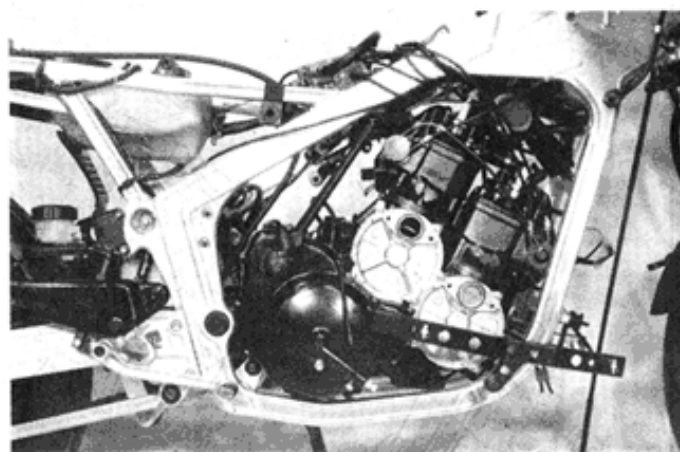

- Gradually lift up the engine, and remove the engine assembly from the right side of the frame.

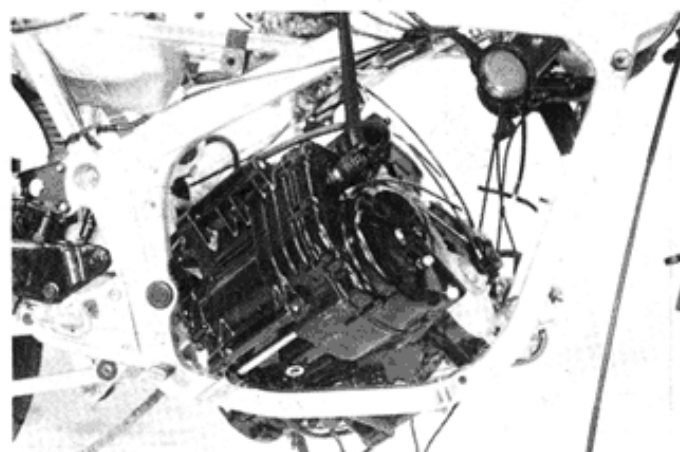

## ENGINE REINSTALLATION

Reinstall the engine in the reverse order of engine removal.

- When remounting the engine, engage the drive chain to the engine sprocket and mount the engine sprocket to the drive shaft.

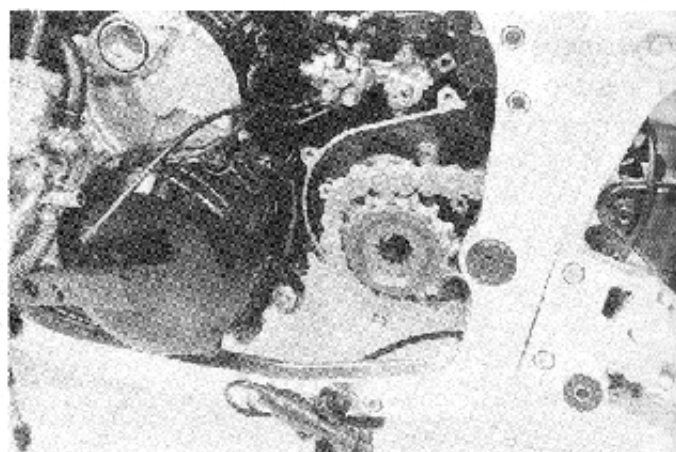

Tightening torque

100 – 130 N·m  
(10.0 – 13.0 kg·m)

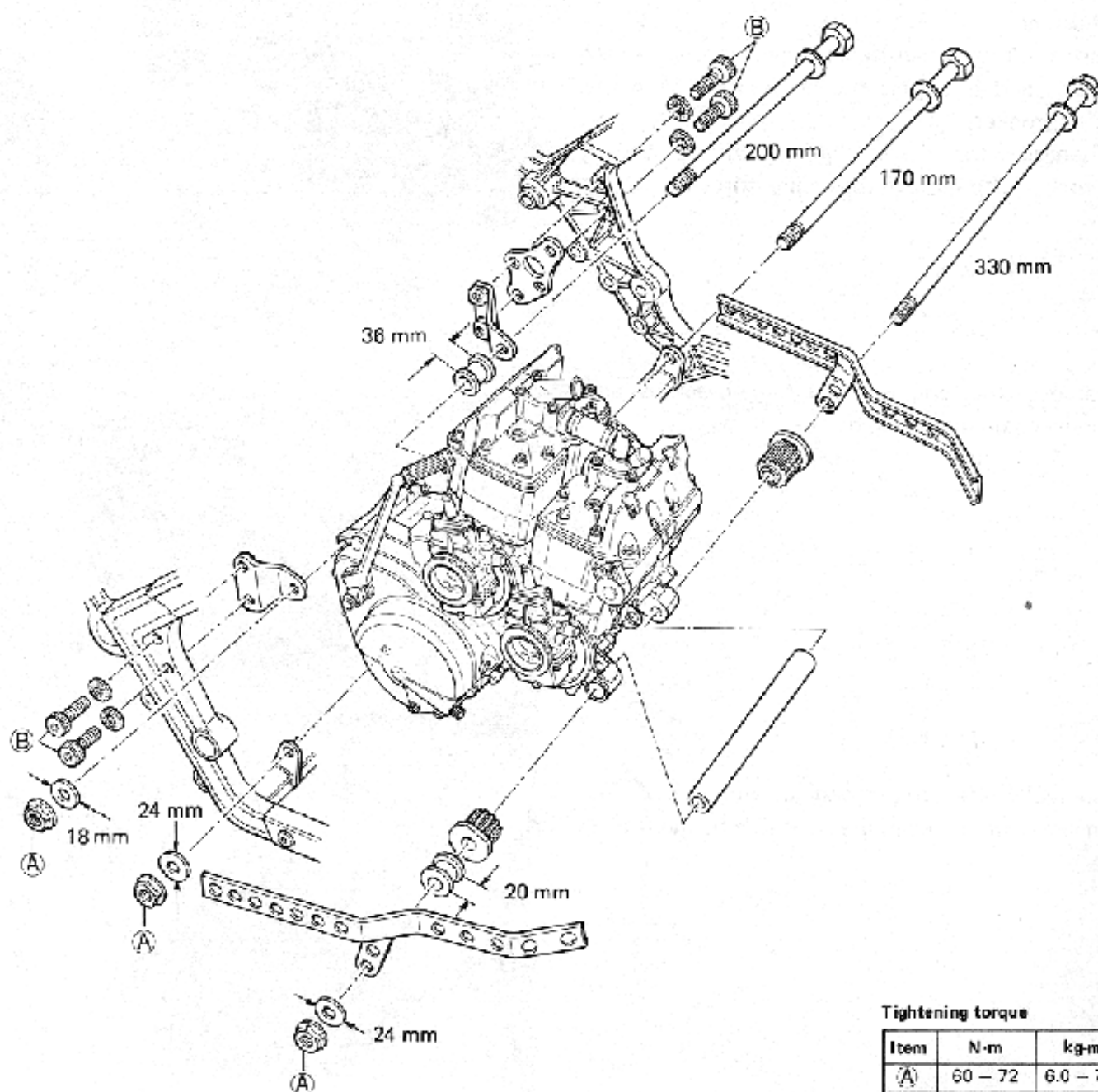

Tightening torque

Item	N·m	kg·m
(A)	60 – 72	6.0 – 7.2
(B)	18 – 28	1.8 – 2.8

- Install the rear shock absorber adjuster mounting plate ① between chassis and engine mounting bracket.
- Route the rear shock absorber adjuster hose properly.

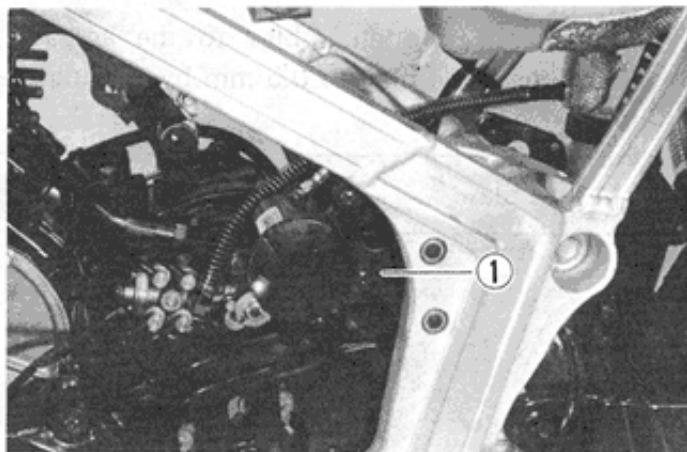

- Before inserting the front engine mounting bolt, insert the lower fairing bracket ② to the mounting bolt.

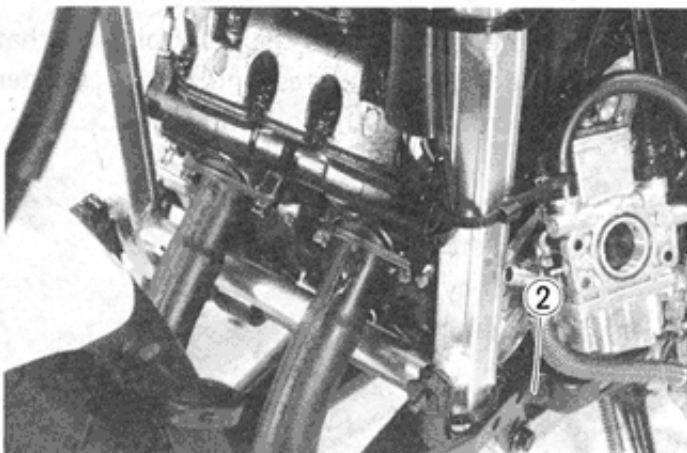

- Apply grease to the gearshift lever mounting boss.
- Align the index line ③ on the gearshift shaft with the cut ④ of the gearshift lever.

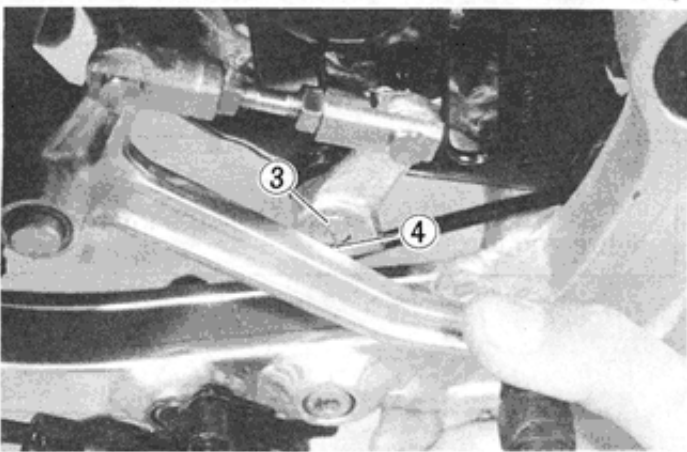

- Align the index line ⑤ on the actuator body with the mark ⑥ on the pulley by turning the pulley.
- Connect the each exhaust valve control cable to the respective positions of the actuator.
- No. 1 cable is connected to "1" position of the actuator.

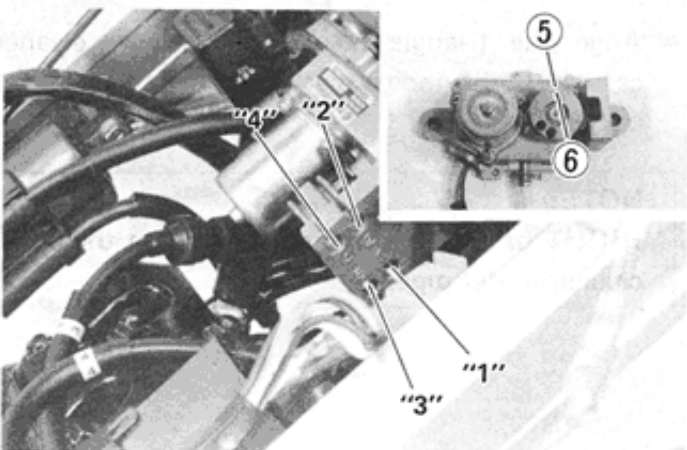
**NOTE:**

- \* Nos. 1 and 2 cables are shorter than Nos. 3 and 4 cables.
- \* The exhaust valves should be in open position when connecting the cables. (Refer to page 3-35.)

### 3-9 ENGINE

- After connecting all cables to the actuator, adjust the cable play to 0.5 mm by turning the adjuster.

Cable play	0.5 mm
------------	--------

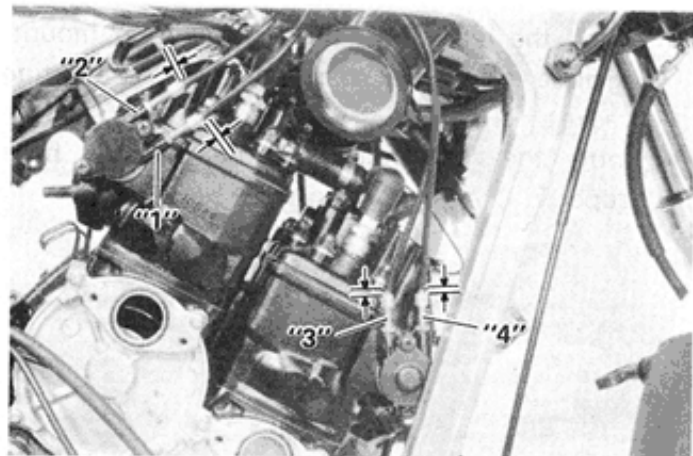

- Replace the plug caps on the spark plugs so that their code markings correspond to the cylinder numbers arranged in the following order.

- ① Front left cylinder
- ② Front right cylinder
- ③ Rear left cylinder
- ④ Rear right cylinder

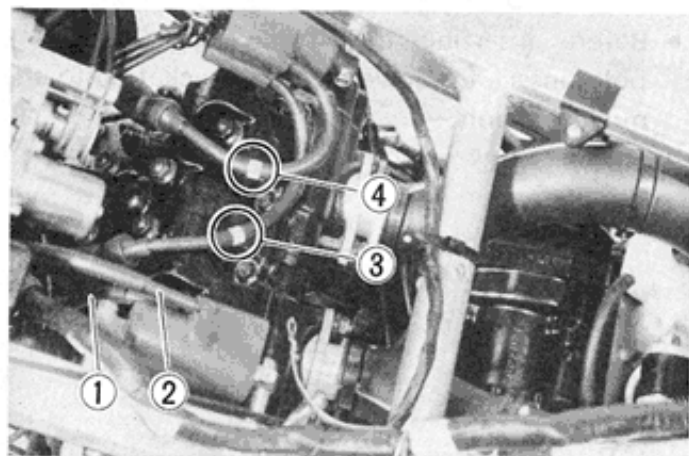

- Install the O-rings ⑤ on the outer valve seat and carburetor outlet.

Carburetor mounting bolt tightening torque	7 – 9 N·m (0.7 – 0.9 kg·m)
--	-------------------------------

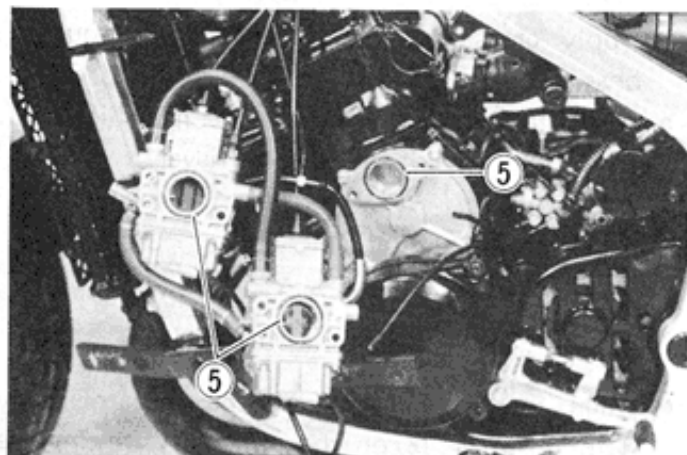

- Align the triangle mark ⑥ on the air cleaner case with the index mark ⑦ on the air cleaner outlet pipe.

**NOTE:**

RIGHT or LEFT mark is provided on the air cleaner outlet pipe.

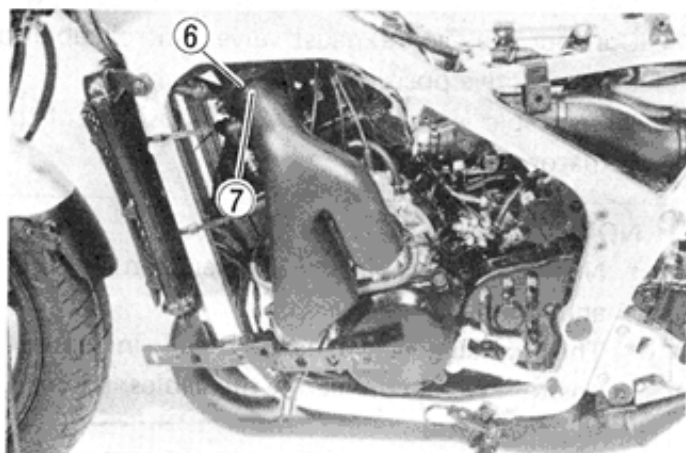

- Install 800 ml (when overhauling engine) of transmission oil SAE 20W/40 into the engine. Check the oil level by removing the transmission oil level screw ①.

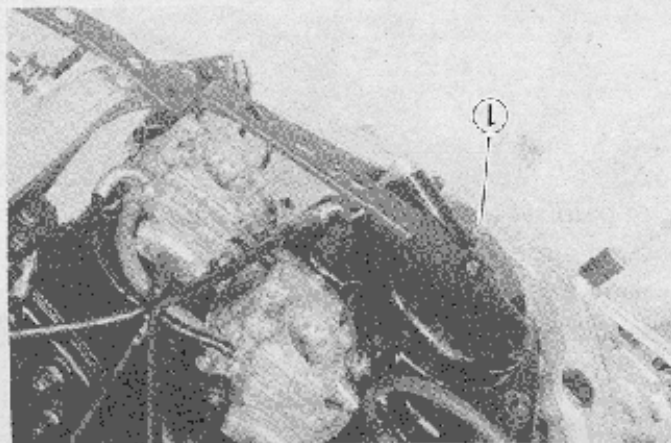

- Install the gear shift lever and adjust the height ① by turning the adjuster ②.

Gearshift pedal height	40 – 45 mm
------------------------	------------

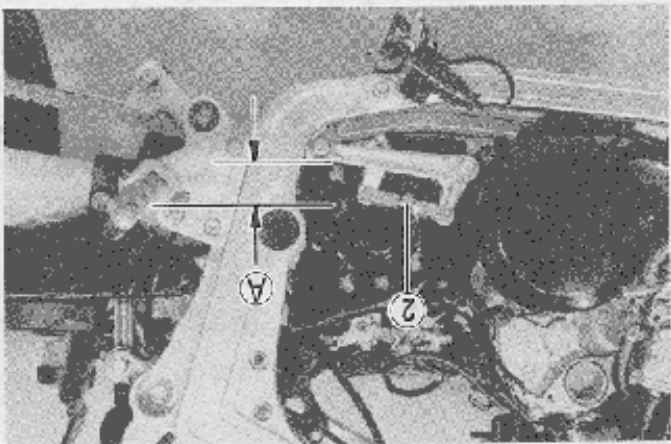

- After remounting the engine, route wiring harness, hoses and cables properly by referring to the sections, wire routing and cable routing, and adjust the following items to the specification.

Page

* Rear brake pedal	2-13
* Brake light switch	2-13
* Clutch cable	2-8
* Throttle cables	2-7
* Choke cables	2-7
* Balancing carburetors	5-9
* Idling adjustment	2-6
* Filling cooling solution	2-10
* Exhaust valve operation	6-9
* Oil pump control cable	2-8
* Bleeding air from oil pump	5-10

## ENGINE DISASSEMBLY

### CAUTION:

Be sure to identify each removed part such as cylinder, piston, rotary disc valve, exhaust valve etc. as to its location and lay the parts out in groups so that each will be restored to the original location during assembly.

- Remove the kick starter lever.

Tightening torque	18 – 28 N·m (1.8 – 2.8 kg-m)
-------------------	---------------------------------

- Loosen the cylinder head nuts and bolts in the criss-cross manner.
- Loosen the water hose clamps and remove the thermostat cover and water hose union from the cylinder heads.
- Remove the thermostat from the rear cylinder head.

### Tightening torque

Bolts	10 – 12 N·m (1.0 – 1.2 kg-m)
Nuts	20 – 24 N·m (2.0 – 2.4 kg-m)

#### REAR CYLINDER HEAD

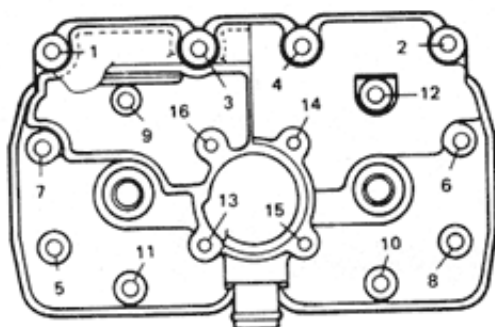

#### FRONT CYLINDER HEAD

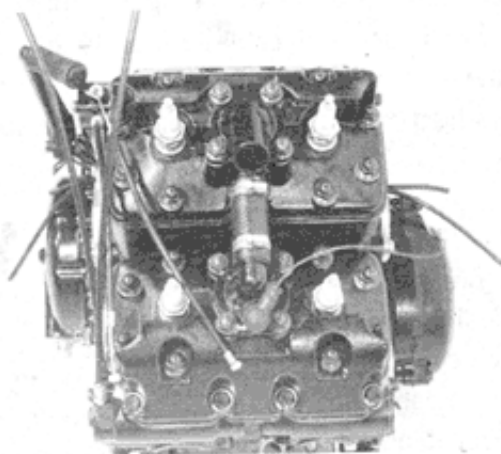
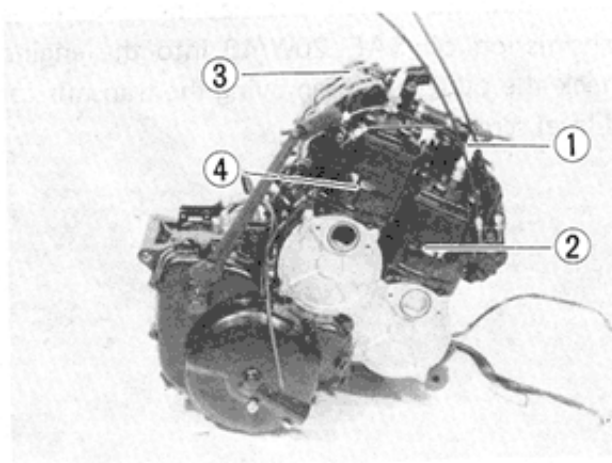
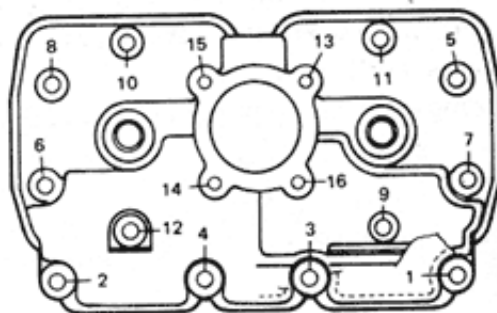

- Remove the four cylinders. Loosen the bolts in the criss-cross manner.

**NOTE:**

Scribe the cylinder No. on the cylinder.

Tightening torque	23 – 27 N·m (2.3 – 2.7 kg-m)
-------------------	---------------------------------

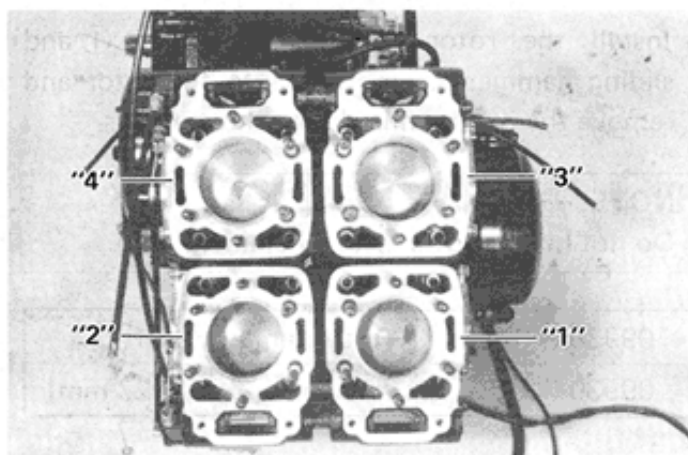

- Place a cloth beneath the piston so as not to drop the parts in the crankcase, and remove the circlip with pliers.
- Remove the piston, piston pin bearing and thrust washers.

**NOTE:**

Scribe the cylinder No. on the piston crown.

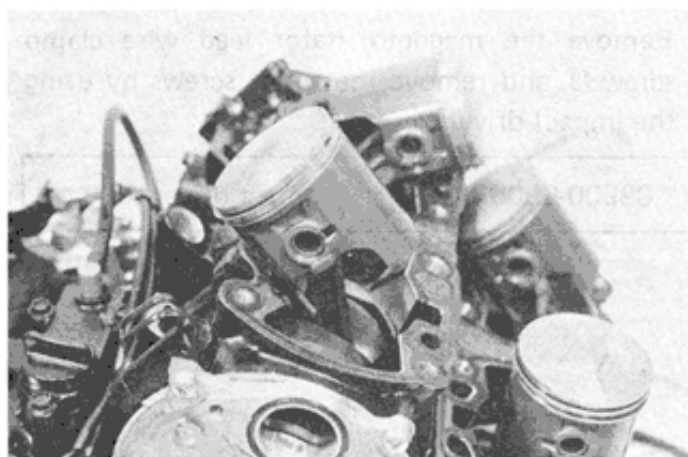

- Remove the magneto cover and dust seal.

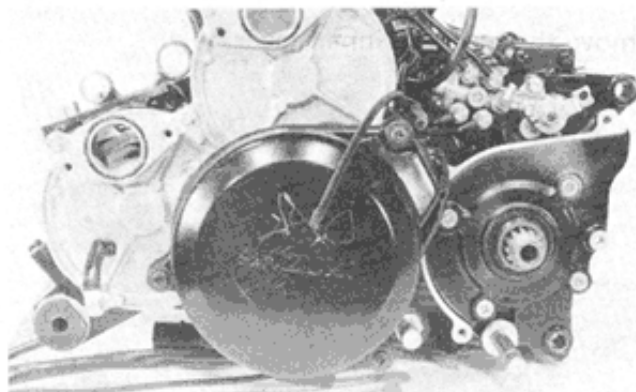

- Remove the magneto rotor nut while holding the rotor with the special tool.

09930-40113	Rotor holder
-------------	--------------

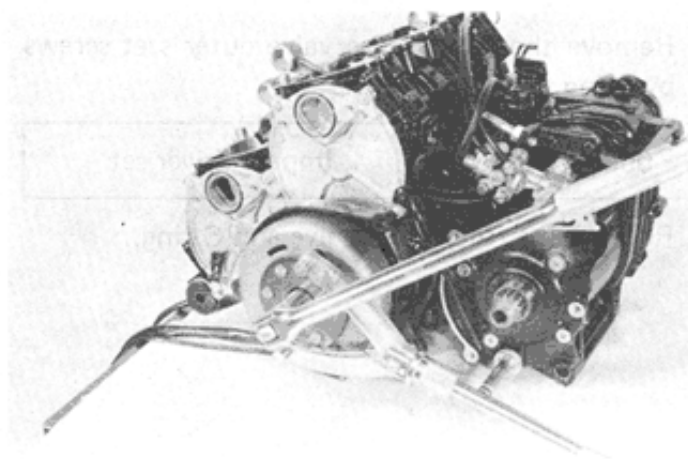

- Install the rotor remover attachment ① and sliding hammer assembly ② into the rotor and remove the rotor while sliding the remover.

**NOTE:**

Do not hit the rotor with a hammer.

09930-30102	Rotor remover shaft
09930-30161	Attachment "C" (27 mm)

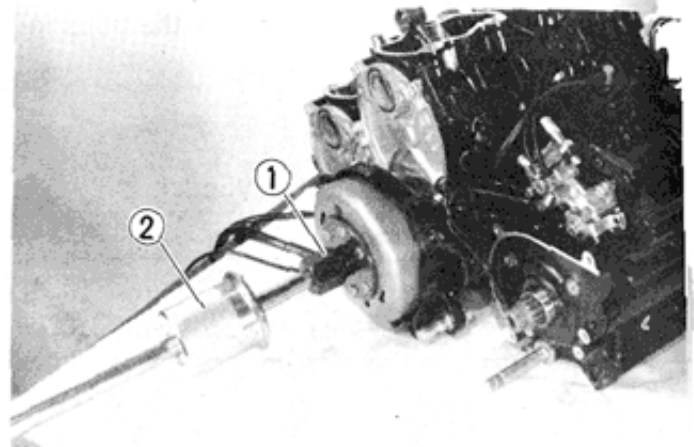

- Remove the magneto stator lead wire clamp screw ③ and remove the stator screws by using the impact driver.

09900-09003	Impact driver set
-------------	-------------------

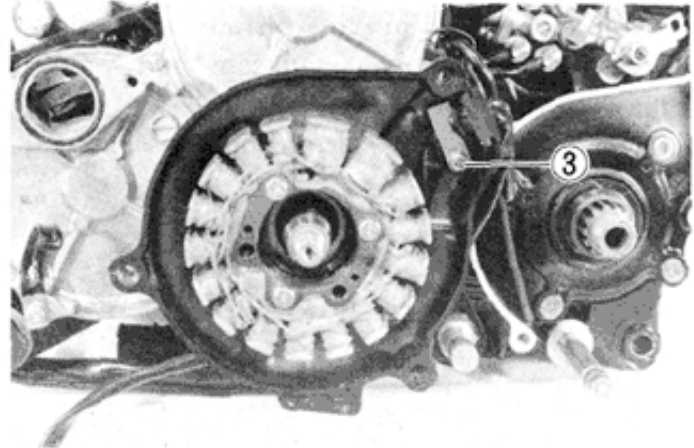

- Remove the magneto inner cover.

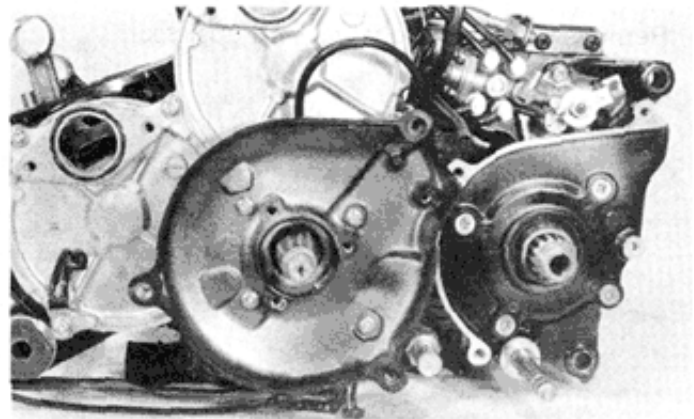

- Remove the rotary disc valve outer seat screws by using the impact driver.

09900-09003	Impact driver set
-------------	-------------------

- Remove the rotary disc valve and O-ring.

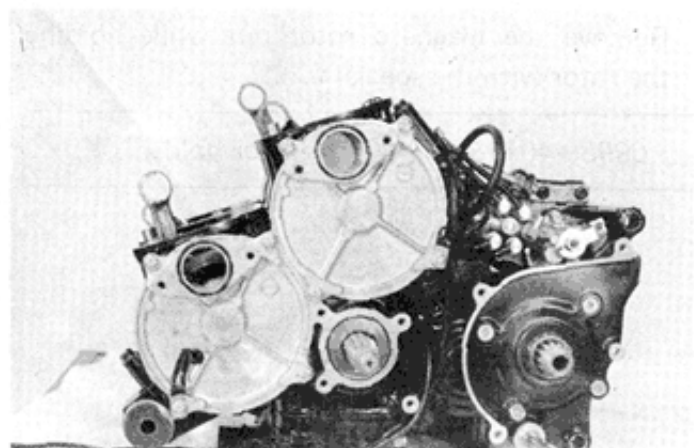

- Remove the rotary disc valve inner seat.

09900-09003

Impact driver set

**NOTE:**

Make sure that the four rotary disc inner valve seats are removed to separate the crankcase.

- Remove the upper crankcase bolts in the order of the following illustration.

**Tightening torque**

6-mm bolt	9 – 13 N·m (0.9 – 1.3 kg-m)
8-mm bolt	20 – 24 N·m (2.0 – 2.4 kg-m)

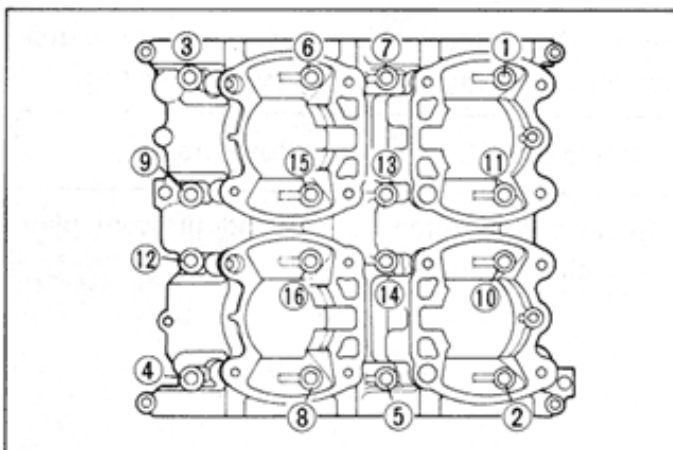
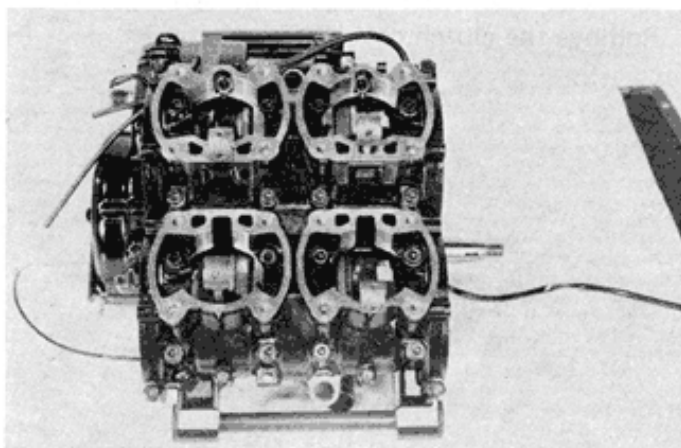
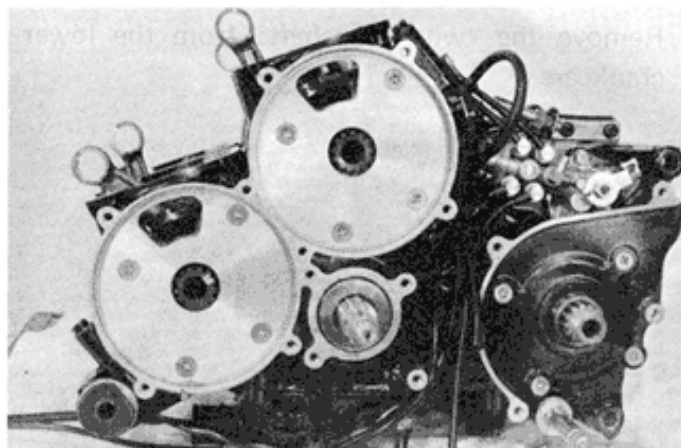

- Using the cylinder disassembling tool, remove the upper crankcase from the lower case.

09912-34510

Cylinder disassembling tool

**CAUTION:**

Make sure that all case bolts have been removed.

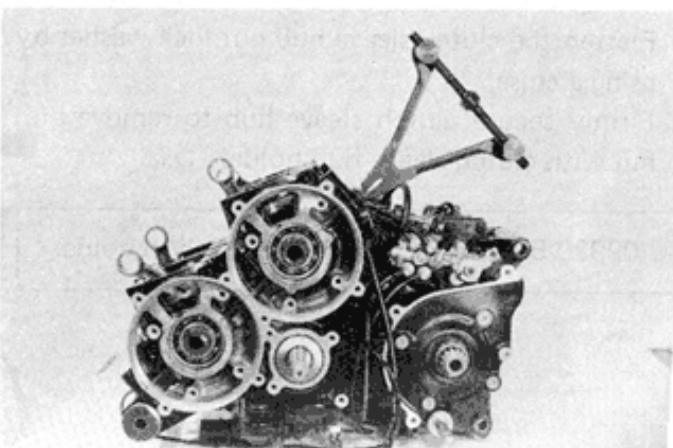

- Remove the two crankshafts from the lower crankcase.

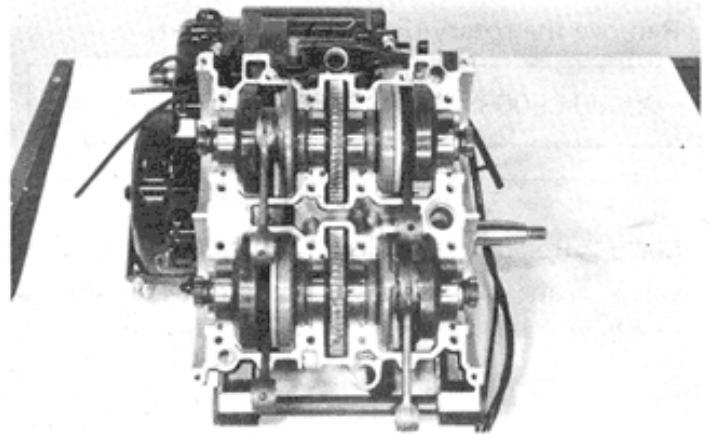

- Remove the clutch cover and gasket.

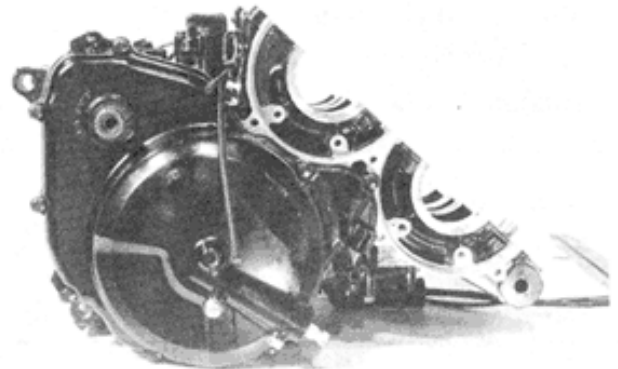

- Hold the primary shaft and loosen the clutch spring mounting bolts in a criss-cross manner.

09900-40113	Rotor holder
-------------	--------------

- Remove the clutch springs and pressure plate with clutch release rack.

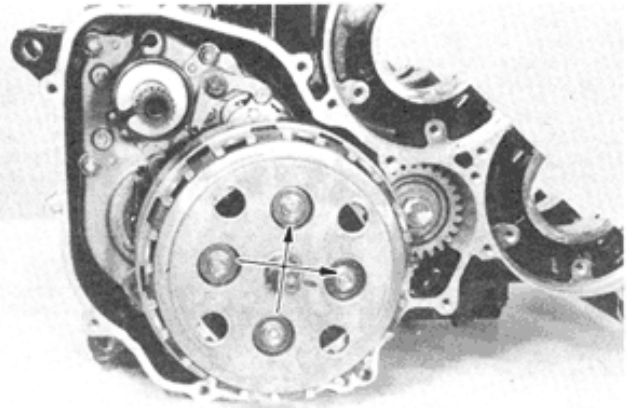

- Flatten the clutch sleeve hub nut lock washer by using a chisel.
- Firmly secure clutch sleeve hub to remove hub nut with clutch sleeve hub holder ①.

09920-53722	Clutch sleeve hub holder
-------------	--------------------------

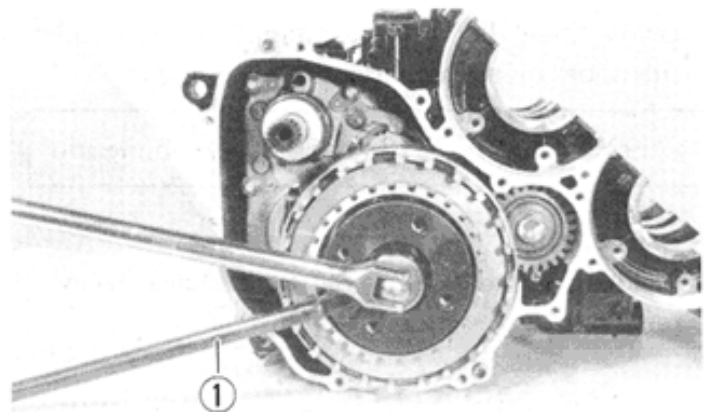

- Remove the clutch sleeve hub, thrust washer and primary driven gear.

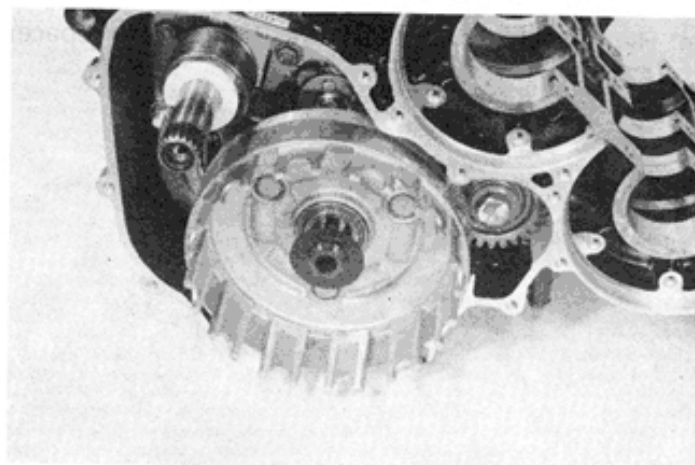

- Remove the spacer, bearing and thrust washer from the countershaft.

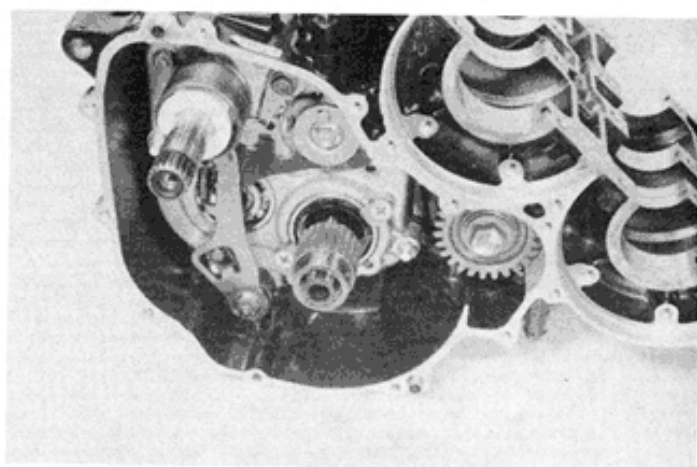

- Remove the clip ① and washer ② from the gearshift shaft.

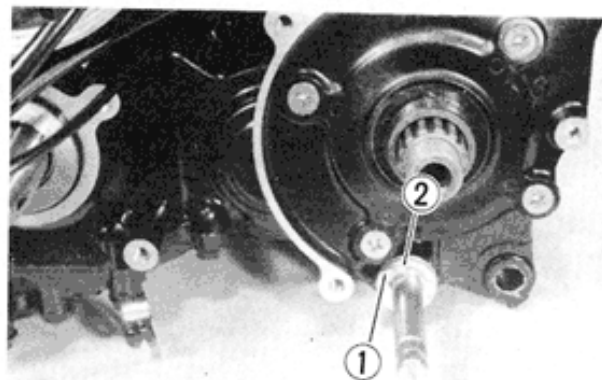

- Remove the gearshift shaft.

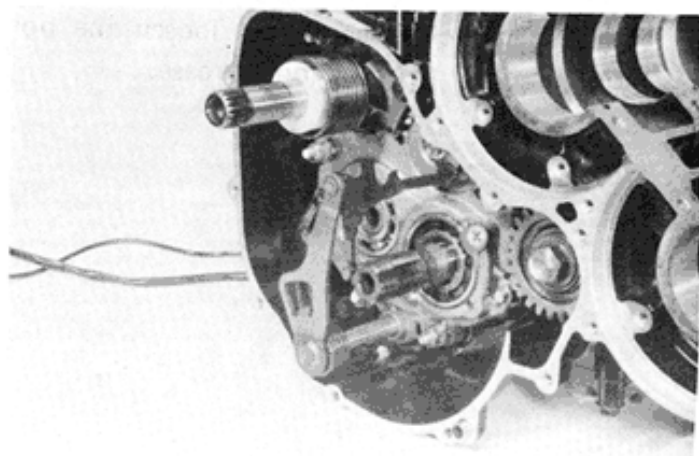

- Remove the engine sprocket inner cover, spacer and O-ring.

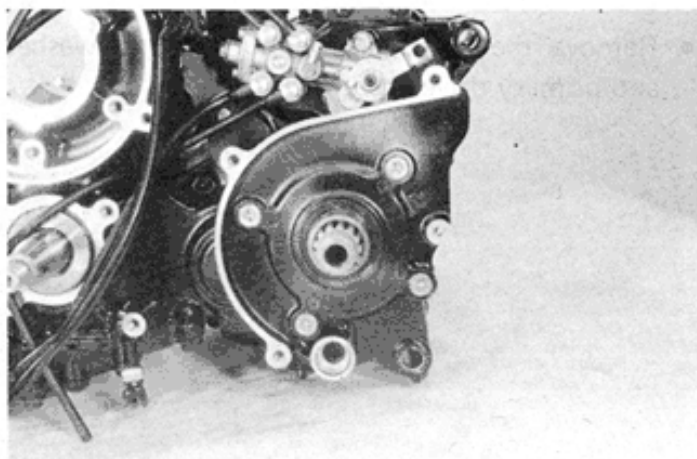

- Remove the oil pump.

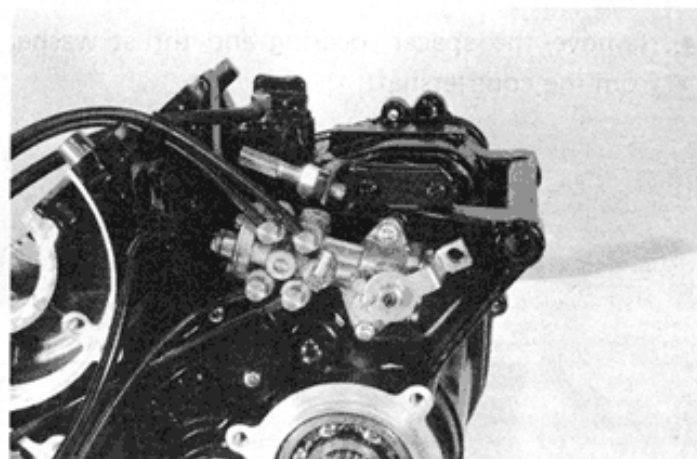

- Remove the neutral switch body, O-ring, switch contact and spring.

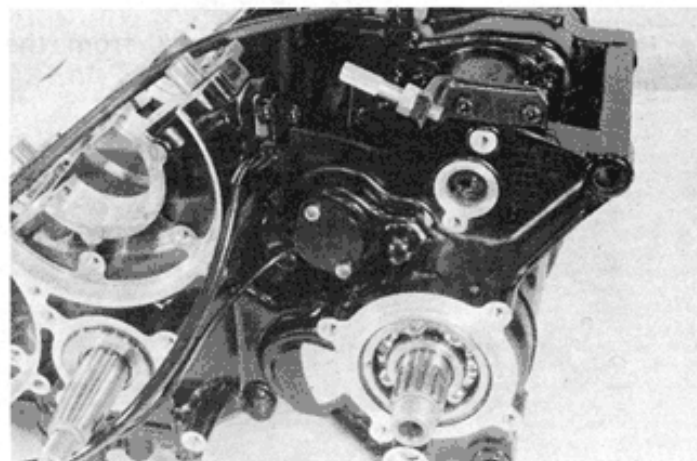

- Flatten the lock washers and loosen the bolt and nuts of the transmission gearcase.

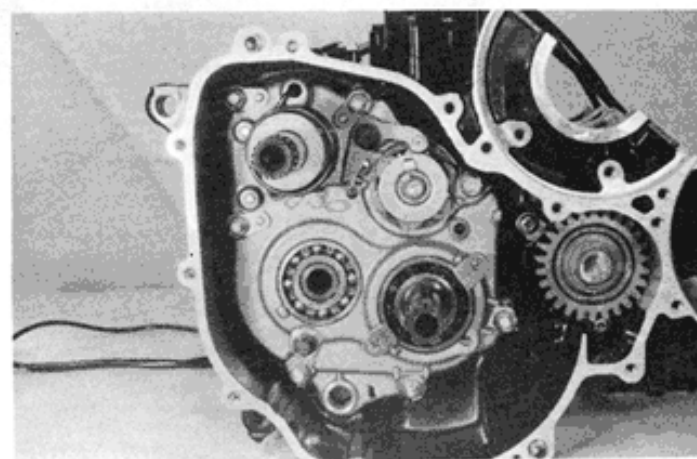

- Draw out the transmission assembly from the lower crankcase.

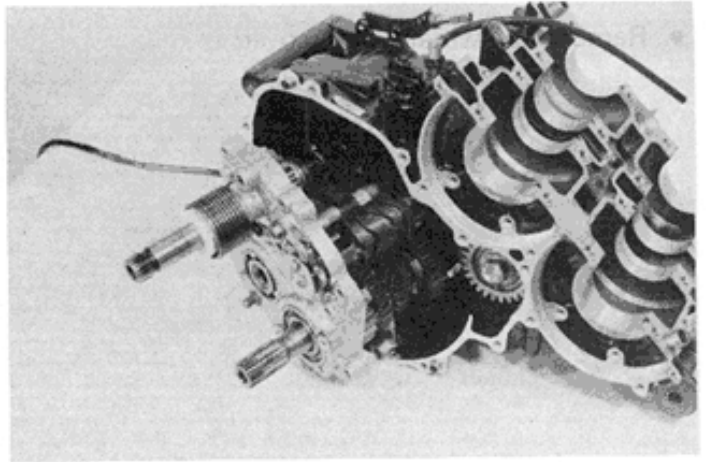

- Remove the breather cap.

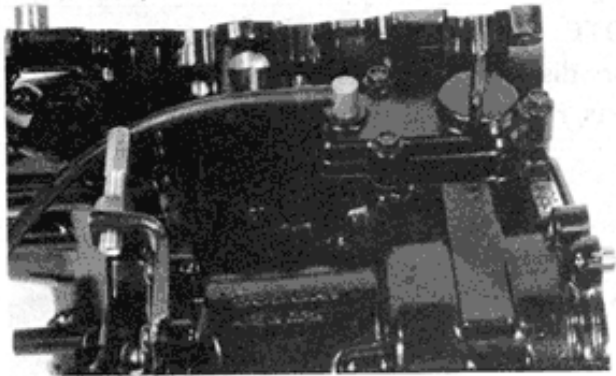

- Remove the pick-up coil.

**NOTE:**

One of the screw holds the lead wire clamp.

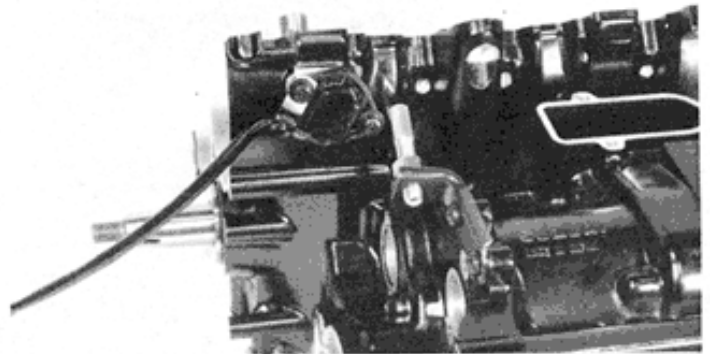

- Temporarily install the magneto rotor to the pilot shaft and remove the primary drive gear from the pilot shaft by using the rotor holder.

09930-40113

Rotor holder

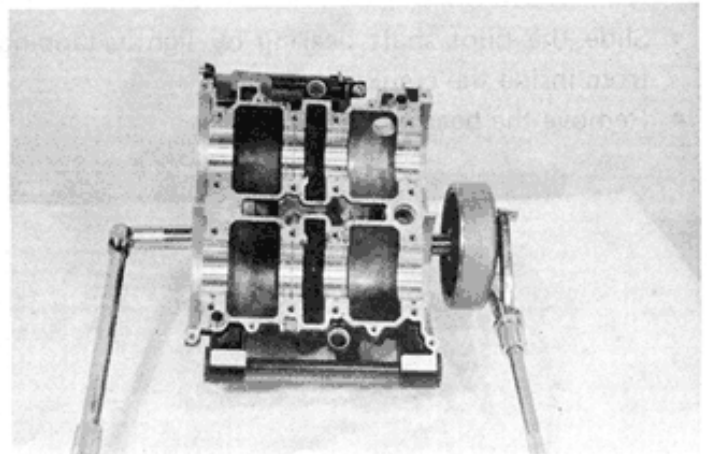

- Remove the water pump cover.

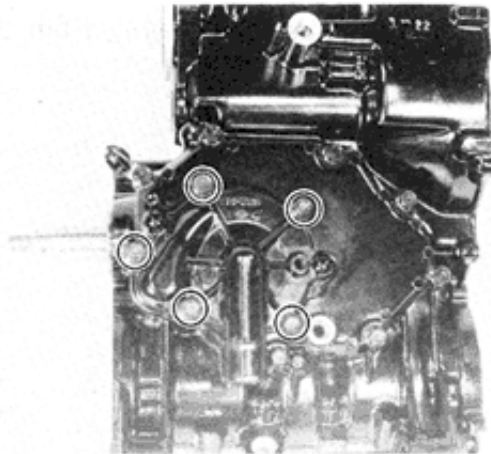

- Remove the oil pan from the lower crankcase.

**NOTE:**

For disassembling the water pump related parts, refer to page 4-6.

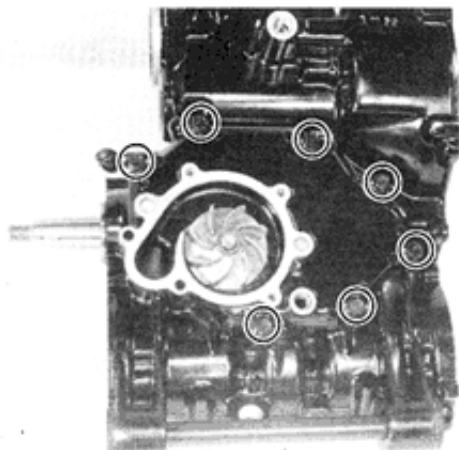

- Remove the pilot shaft holder.

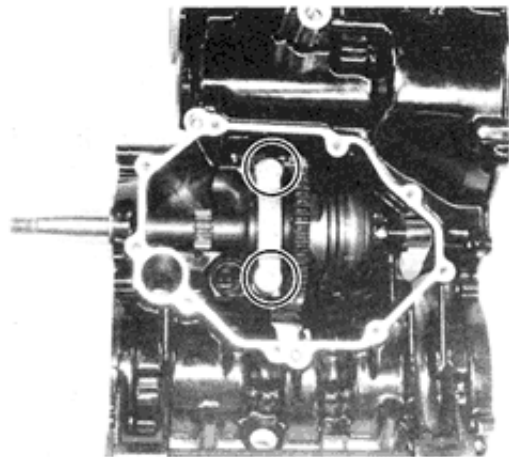

- Slide the pilot shaft bearing by lightly tapping from inside the crankcase.
- Remove the bearing.

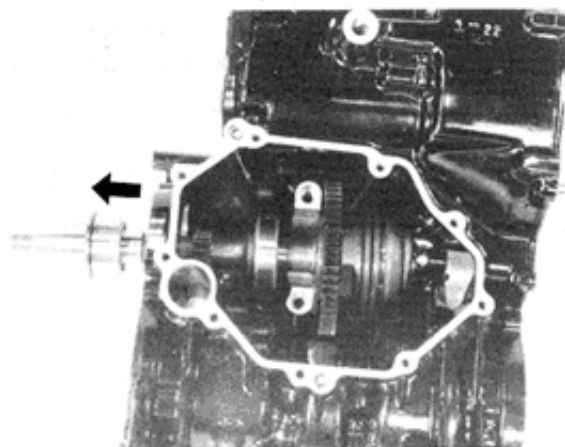

- Slide the pilot shaft to the left and remove the pilot shaft.

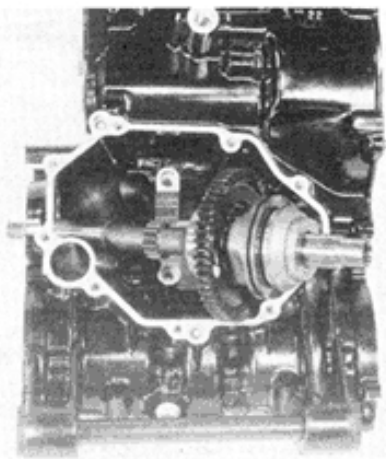

- Remove the pilot shaft bearing with a suitable drift.

**CAUTION:**

The removed bearing should be replaced with a new one.

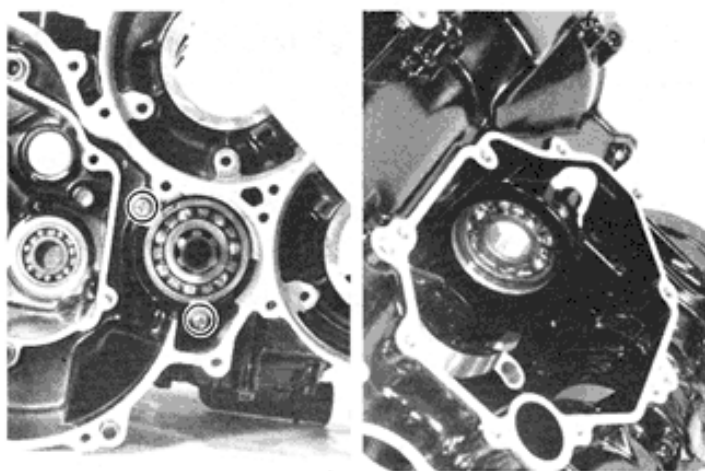

- Remove the gearshift fork shafts and gearshift forks.

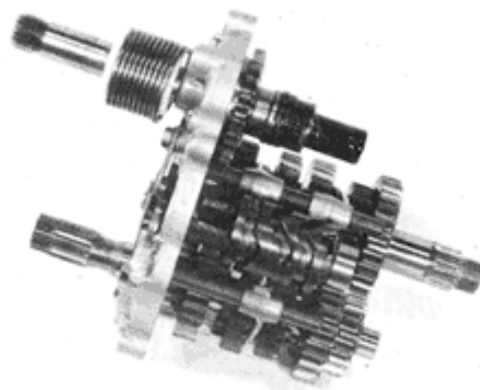

- Remove the countershaft and drive shaft.

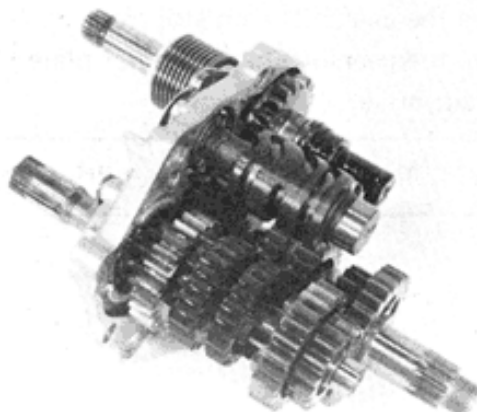

- Remove the kick starter drive gear.

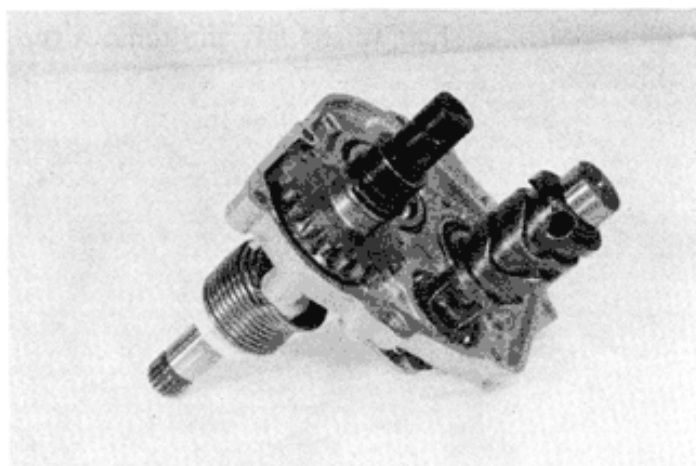

- Remove the kick starter return spring guide and return spring.

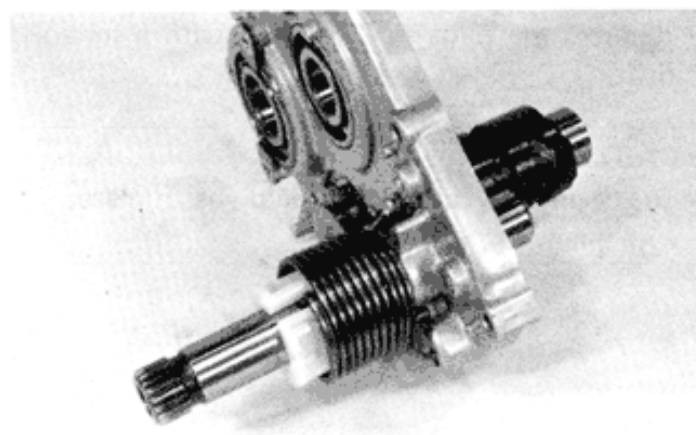

- Remove the kick starter shaft.

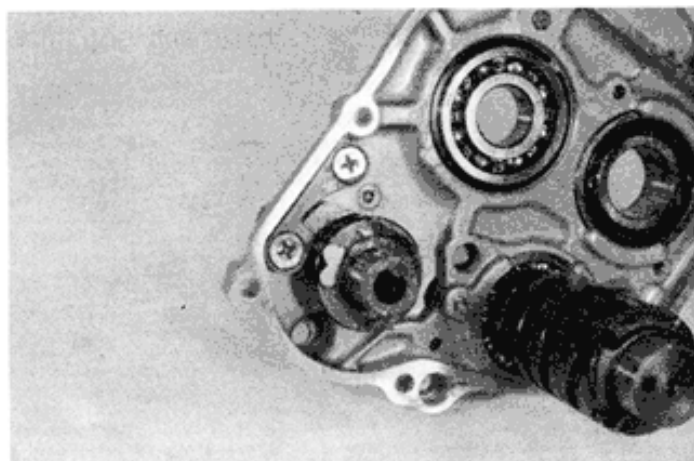

- Remove the gearshift cam stopper and its spring.
- Remove the gearshift cam retainer plate by using an impact driver.

09900-09003

Impact driver set

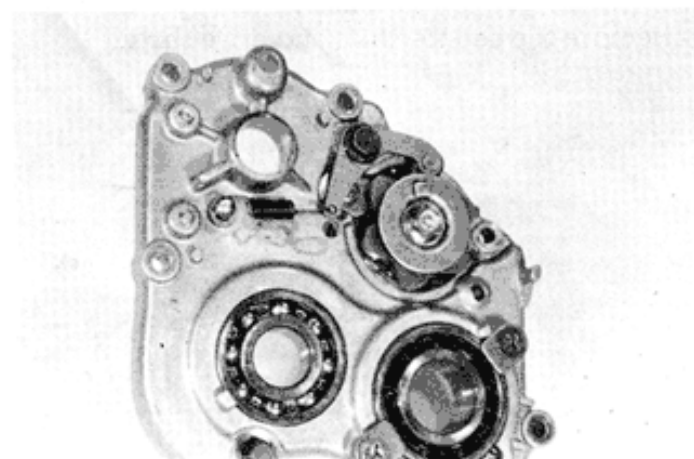

- Remove the gearshift cam pins and gearshift cam.

**NOTE:**

The neutral stopper pin ① is longer than the other pins.

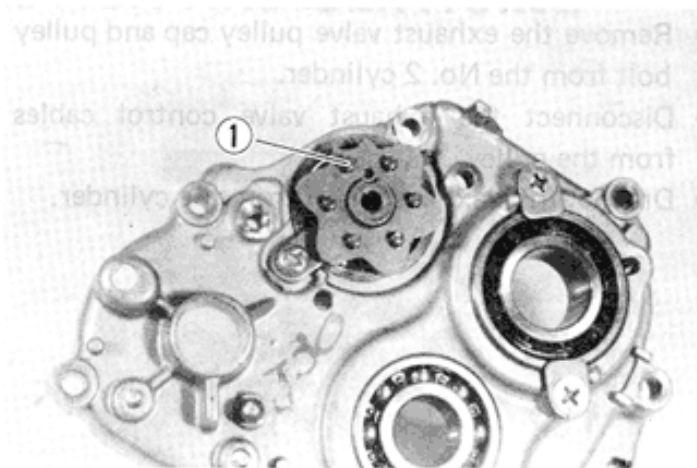

- Remove the respective bearings with a suitable drift.

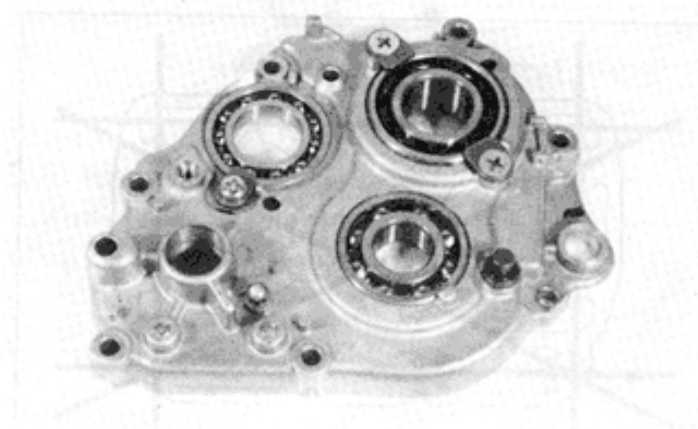

- Remove the clutch pinion stopper bolt ②.
- Tap the pinion from inside and remove the clutch pinion and oil seal.

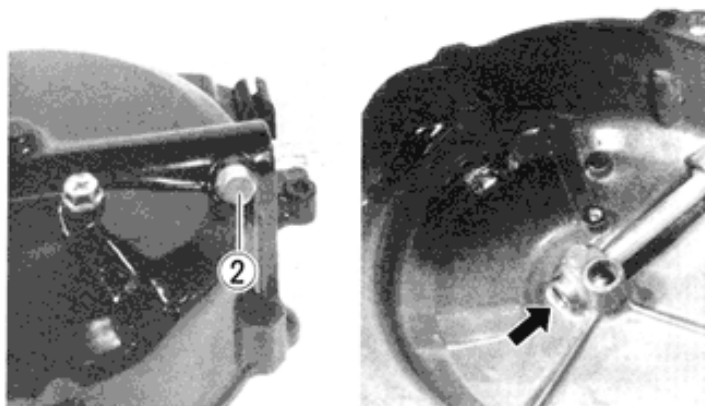

- Remove the exhaust valve pulley cap and pulley from the No. 4 cylinder.
- Disconnect the exhaust valve control cables from the pulley.
- Draw out the exhaust valve from the cylinder.

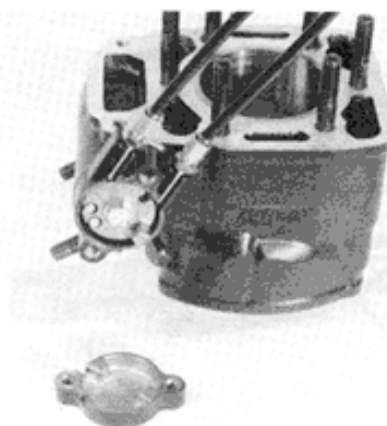

### 3-23 ENGINE

---

- Remove the exhaust valve pulley cap and pulley bolt from the No. 2 cylinder.
- Disconnect the exhaust valve control cables from the pulley.
- Draw out the exhaust valve from the cylinder.

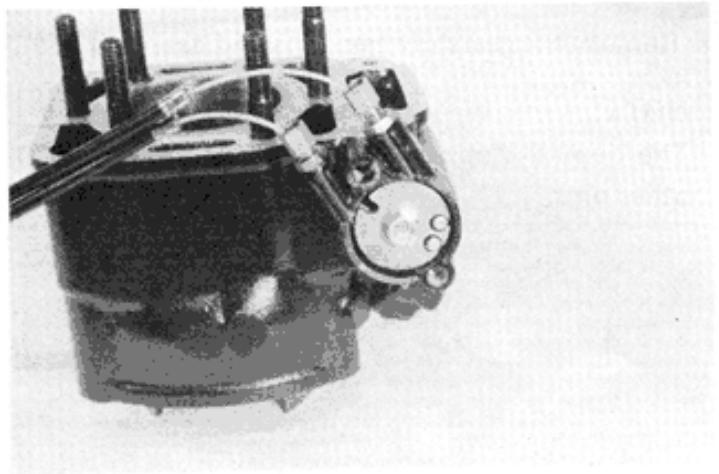

## ENGINE COMPONENTS INSPECTION AND SERVICING

### CYLINDER HEAD

- Remove the carbon and clean the cylinder head.
- Check the scratches on the mating surface.
- Check the gasketed surface of the cylinder head for distortion with a straightedge and thickness gauge, taking a clearance reading at several places indicated. If the largest reading at any position of the straightedge exceeds the limit, replace the cylinder head.

09900-20803	Thickness gauge
-------------	-----------------

Service Limit	0.1 mm
---------------	--------

- If the largest reading at any portion of the straightedge exceeds the limit, rework the surface by rubbing it against emery paper (of about # 400) laid flat on the surface plate in a lapping manner.
- The gasketed surface must be smooth and perfectly flat in order to secure a tight joint. A leaky joint can be the cause of reduced power output and increased fuel consumption.

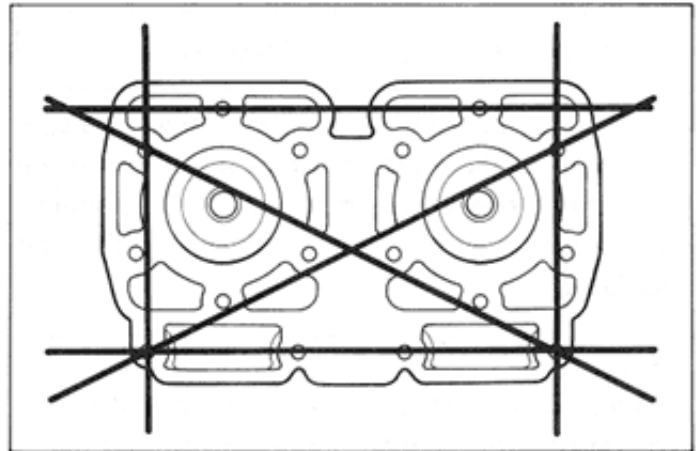
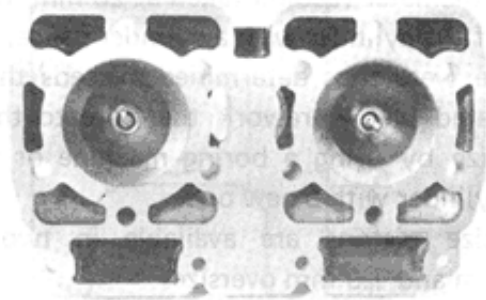

### CYLINDER AND EXHAUST VALVE

- Turn the exhaust valve by hand and check that the exhaust valve turns smoothly.
- Remove the exhaust valves from the respective cylinders.
- Decarbon the exhaust port, exhaust valves and the upper part of the cylinder, taking care not to damage the cylinder wall surface.
- Check the oil seal for any signs of exhaust gas leakage.
- Inspect the exhaust valve and cylinder sliding surface for nicks, scratches, wear or other damage.

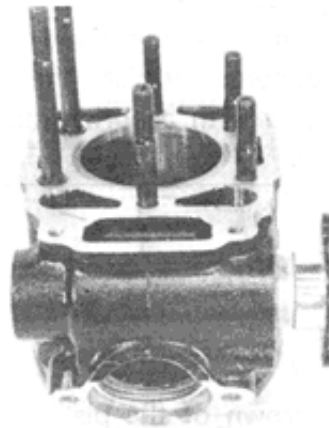

**CYLINDER BORE**

- The wear of the cylinder wall is determined from diameter reading taken at 20 mm from the top of the cylinder with a cylinder gauge.
- If the wear thus determined exceeds the limit indicated below, rework the bore to the next oversize by using a boring machine or replace the cylinder with a new one.
- Oversize pistons are available in two sizes: 0.5 mm and 1.0 mm oversizes.

09900-20508	Cylinder gauge set
-------------	--------------------

Service Limit	56.065 mm
---------------	-----------

- After reworking the bore to an oversize, be sure to chamfer the edges of ports and smooth the chamfered edges with emery paper. To chamfer, use a scraper, taking care not to nick the wall surface.

**NOTE:**  
 Minor surface flaws on the cylinder wall due to seizure or similar abnormalities can be corrected by grinding the flaws off with fine-grain emery paper. If the flaws are deep grooves or otherwise persist, the cylinder must be reworked with a boring machine to the next oversize.

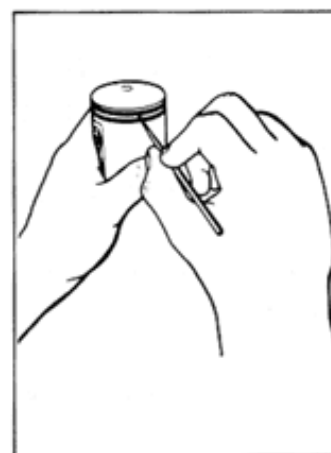
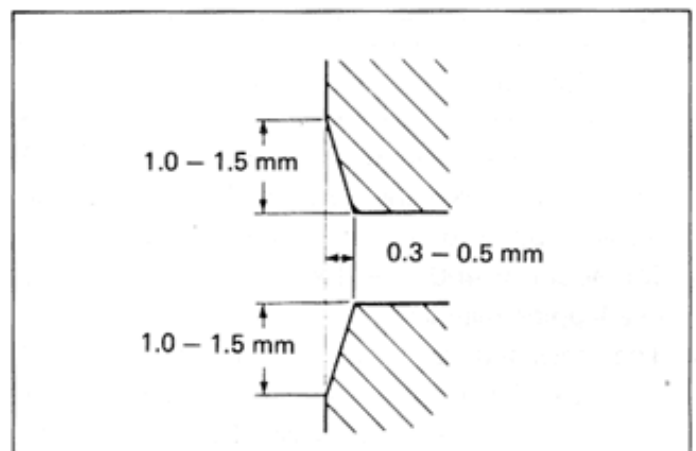
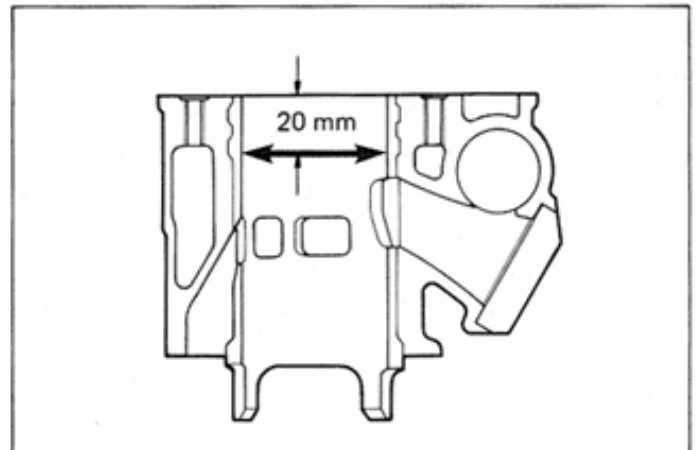

**PISTON**

**DECARBON**

- De-carbon the crown of the piston and piston ring grooves. After cleaning the grooves, fit the rings and rotate them in their respective grooves to be sure that they move smoothly.
- Carbon in groove is liable to cause the piston ring to get stuck in the groove, and this condition will lead to reduced engine power output.
- A piston whose sliding surface is badly grooved or scuffed due to overheating must be replaced.
- Shallow grooves or minor scuff can be removed by grinding with emery paper of about # 400.

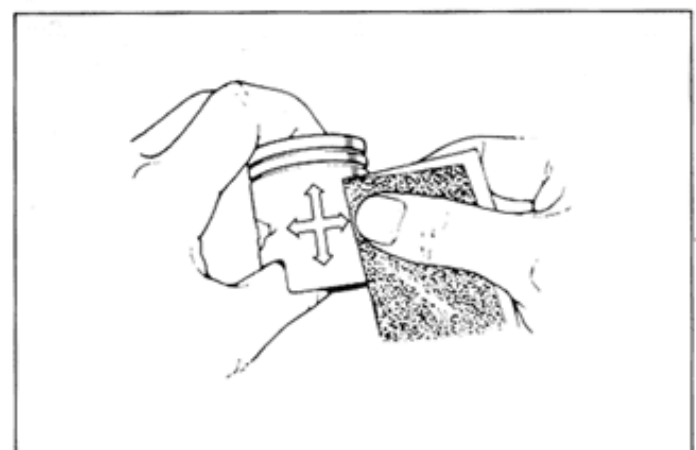

**PISTON DIAMETER**

- Using a micrometer, measure the piston outside diameter at the place 25 mm from the skirt end as shown in Fig.
- If the measurement is less than the limit, replace the piston with a new one.

09900-20203	Micrometer (50 – 75 mm)
-------------	-------------------------

Service Limit	55.880 mm
---------------	-----------

Piston oversize	0.5, 1.0 mm
-----------------	-------------

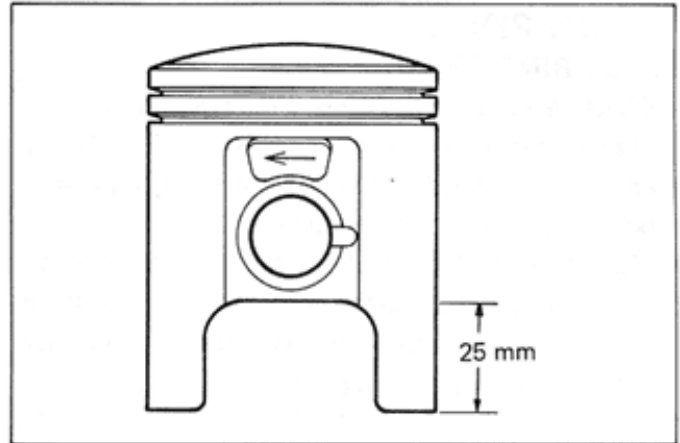
**PISTON-CYLINDER CLEARANCE**

- As a result of the above measurement, if the piston to cylinder clearance exceeds the limit shown in the table below, overhaul the cylinder and use an oversize piston, or replace both cylinder and piston with new ones.

Service Limit	0.120 mm
---------------	----------

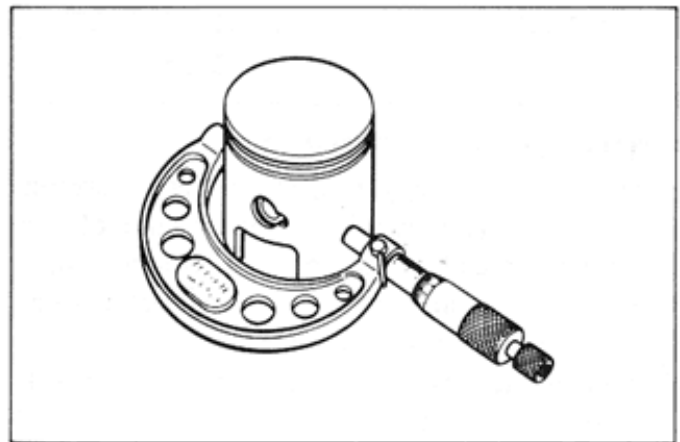
**PISTON PIN BORE**

- Using a caliper gauge, measure the piston pin bore inside diameter.
- If reading exceeds the following service limit, replace it with a new one.

Service Limit	14.030 mm
---------------	-----------

09900-20605	Dial calipers
-------------	---------------

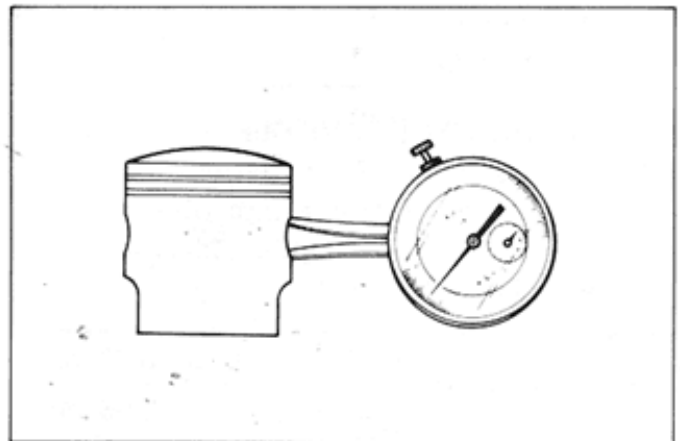
**PISTON PIN O.D.**

- Using a micrometer, measure the piston pin outside diameter at three positions.

09900-20205	Micrometer (0 – 25 mm)
-------------	------------------------

Service Limit	13.980 mm
---------------	-----------

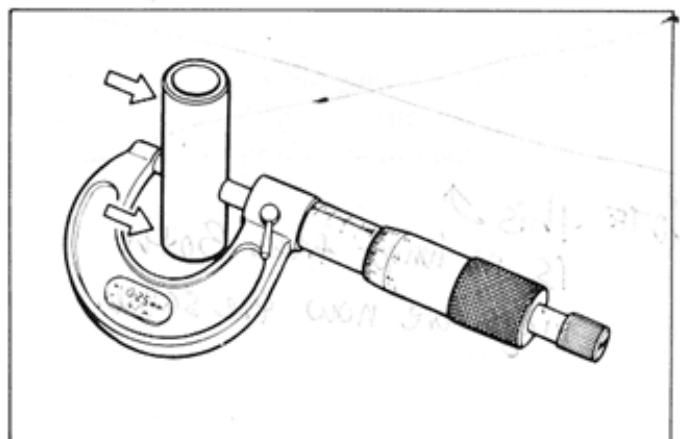

**PISTON RINGS**

**PISTON RING END GAP**

- Check each ring for end gap, reading the gap with a thickness gauge as shown in Fig. If the end gap is found to exceed the limit, indicated below, replace it with a new one.
- The end gap of each ring is to be measured with the ring fitted squarely into the cylinder bore and held at the least worn part near the cylinder bottom, as shown in Fig.

09900-20803	Thickness gauge
Service Limit	0.75 mm

**PISTON RING FREE END GAP**

- As the piston ring wears, its end gap increases reducing engine power output because of the resultant blowby through the enlarged gap. Here lies the importance of using piston rings with end gaps within the limit.
- Measure the piston ring free end gap to check the spring tension.

Service Limit (Top & 2nd rings)	4.0 mm
------------------------------------	--------

**PISTON RING TO GROOVE CLEARANCE**

- Fix the piston ring in the piston ring groove, measure the ring side clearance with the thickness gauge while matching the sliding surface of piston and ring.

Standard clearance	1st	0.03 – 0.07 mm
	2nd	0.01 – 0.05 mm

~~**NOTE:**  
1st ring and 2nd ring differ in the shape. Be sure to bring the "T"-marked side to top when fitting them to the piston.~~

*NOTE this is no longer true. Both rings are now the same.*

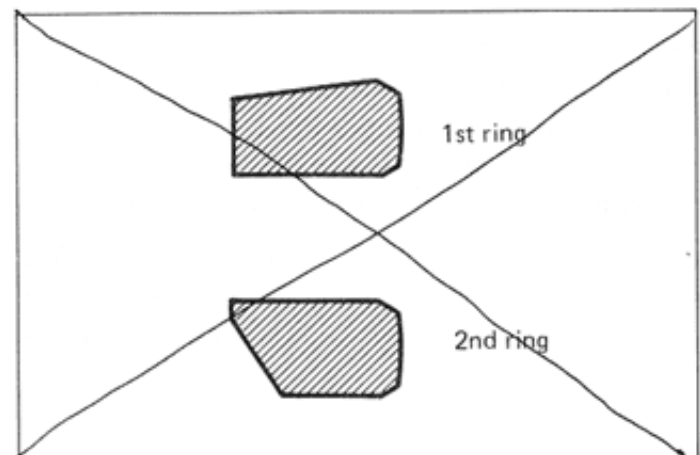
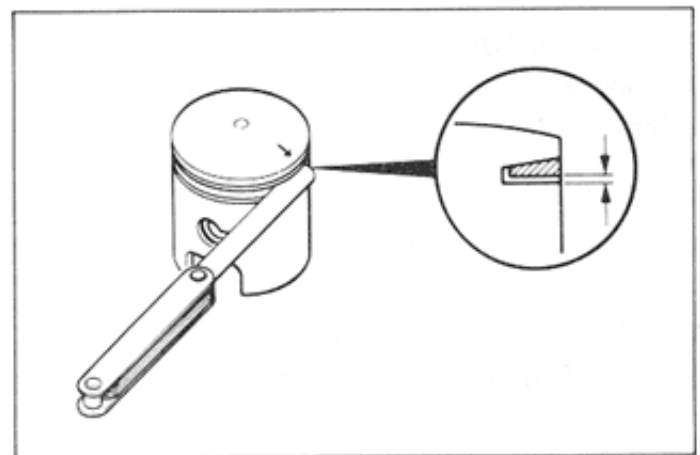
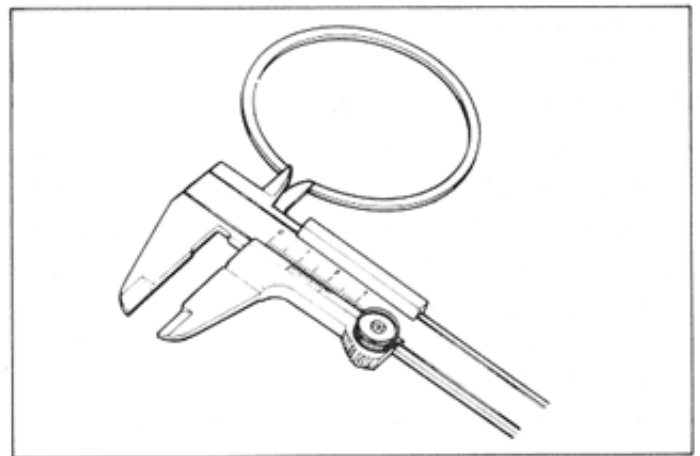
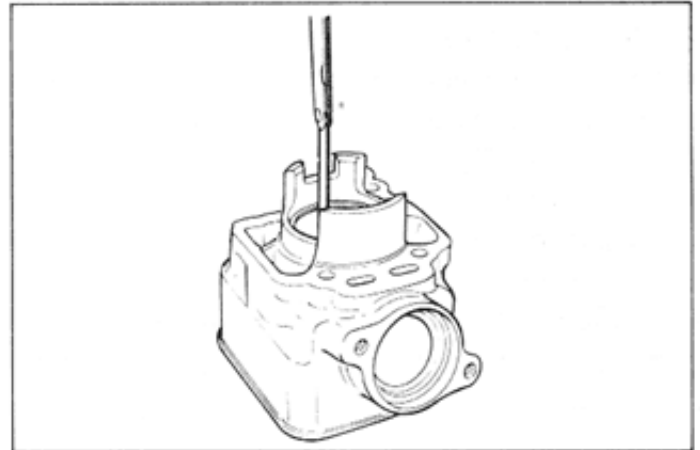

## OVERSIZE PISTON RING

- The following two types of oversize piston rings are used. They bear the following identification numbers.

Size	Mark
0.5 mm O.S.	50
1.0 mm O.S.	100

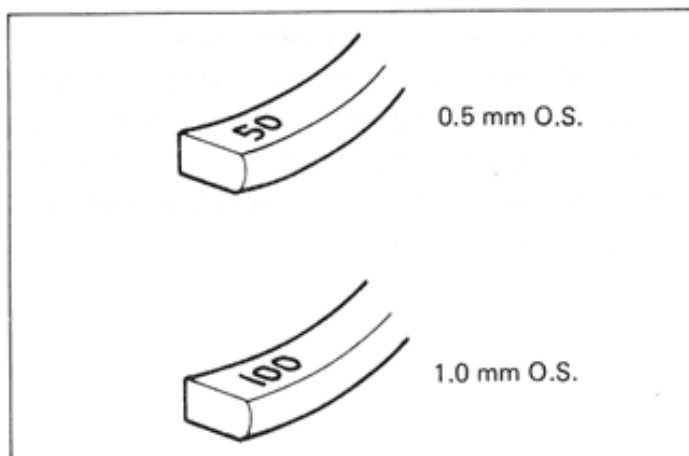

## BEARINGS

- Wash the bearing with cleaning solvent and lubricate with motor oil before inspecting.
- Turn the inner race and check to see that the inner race turns smoothly.
- If it does not turn lightly, quietly and smoothly, or if noise is heard, the bearing is defective and must be replaced with a new one.

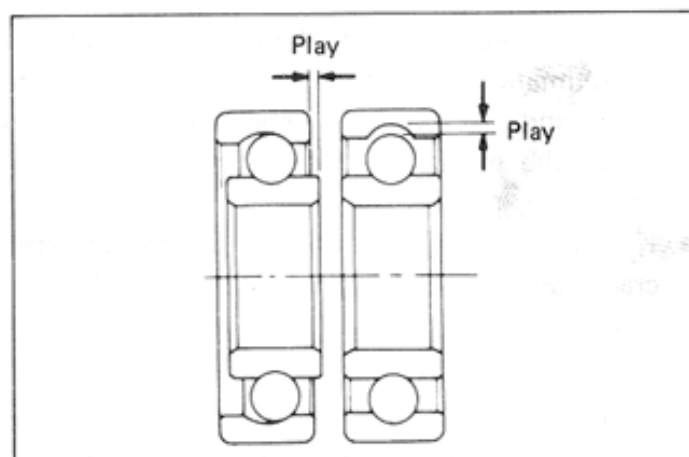

## OIL SEALS

- Damage to the lip ① of the oil seal may result in leakage of the fuel-air mixture or oil. Inspect for damage and be sure to replace damaged oil seals with new ones.

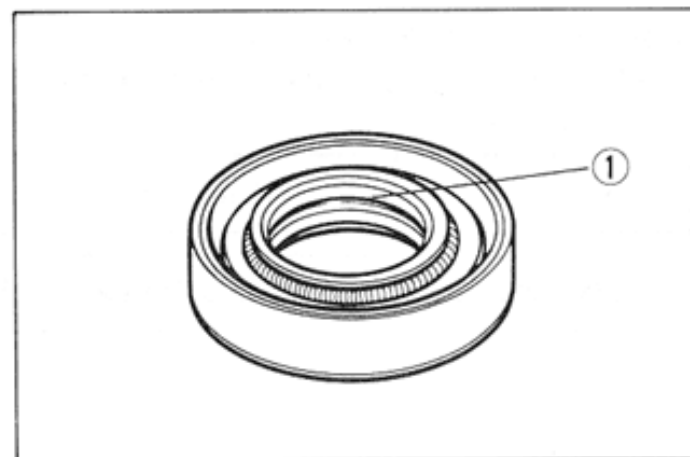

## CRANKSHAFT

### CRANKSHAFT RUNOUT

- Support crankshaft by "V" blocks ①, with the dial gauge ② rigged to read the runout as shown.

Service Limit	0.05 mm
---------------	---------

- Excessive crankshaft runout is often responsible for abnormal engine vibration. Such vibration shortens engine life.

09900-21304	V-block
09900-20701	Magnetic stand
09900-20606	Dial gauge (1/100 mm)

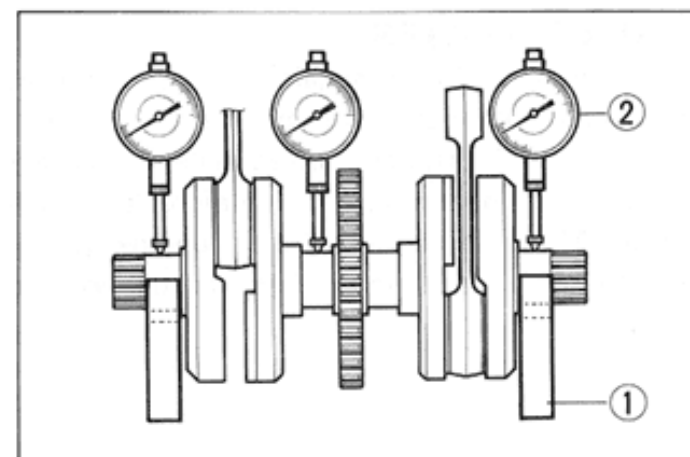

**CONDITION OF BIG END BEARING**

- Turn the crankshaft with the connecting rod to feel the smoothness of rotary motion in the big end. Move the rod up and down while holding the crankshaft rigidly to be sure that there is no rattle in the big end.

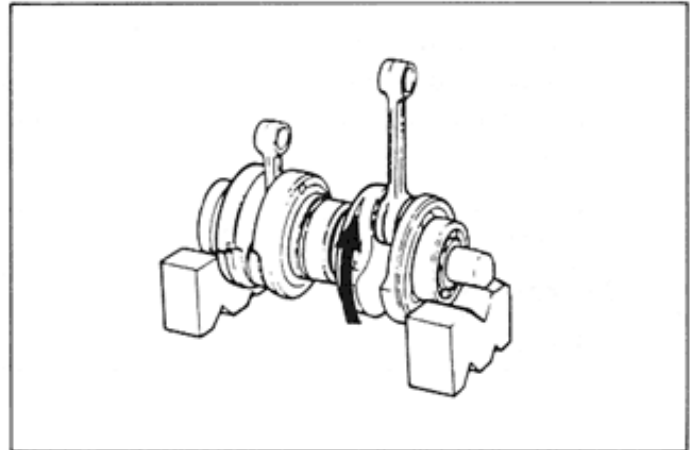

- Wear on the big end of the connecting rod can be estimated by checking the movement of the small end of the rod. This method can also check the extent of wear on the parts of the connecting rod's big end.
- If wear exceeds the limit, connecting rod, crank pin and crank pin bearing should all be replaced.

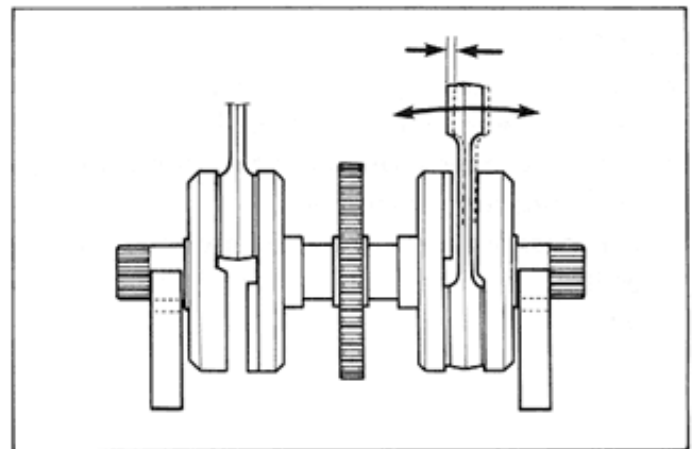

Service Limit	3.0 mm
---------------	--------

**CON-ROD SMALL END BORE I.D.**

- Using a caliper gauge, measure the con-rod small end diameter.

Service Limit	18.040 mm
---------------	-----------

09900-20605	Dial calipers
-------------	---------------

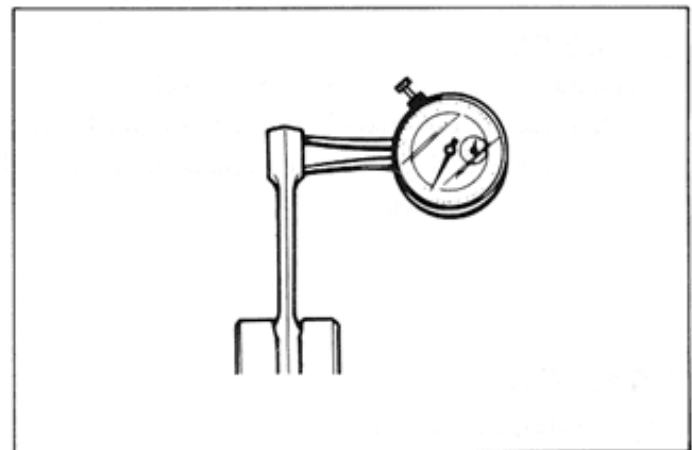

**CLUTCH PLATES**

Clutch plates in service remain in oily condition as they were lubricated with oil. Because of this condition, both drive and driven plates are subject to little wearing action and therefore last much longer. Their life depends largely on the quality of oil used in the clutch and also on the way the clutch is operated.

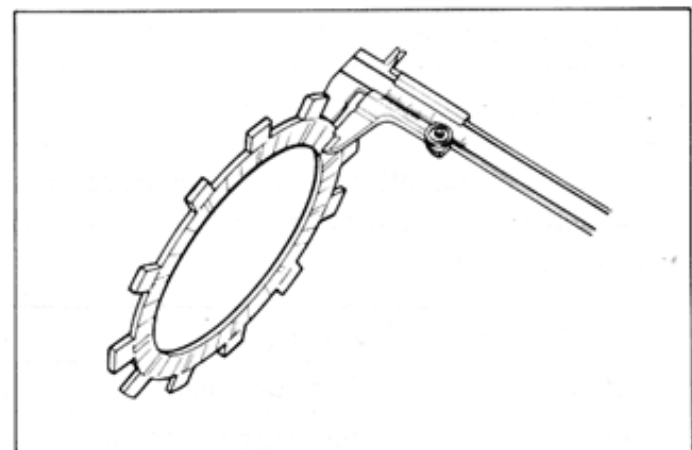

Checking thickness

These plates are expendable: they are meant to be replaced when found worn down or distorted to the respective limit: use a caliper to check thickness and a thickness gauge and surface plate to check distortion.

09900-20102	Vernier calipers
09900-20803	Thickness gauge

Unit: mm

Service Limit	Drive plate	Driven plate
Thickness	2.4	—
Distortion	—	0.1
Claw width	13.05	—

### CLUTCH SPRING FREE LENGTH

Measure the free length of each coil spring with vernier calipers, and compare the elastic strength of each with the specified limit. Replace all the springs if any spring is not within the limit.

#### Clutch spring free length

Service Limit	34.9 mm
---------------	---------

### CLUTCH BEARINGS

Inspect clutch bearing for any abnormality, particularly cracks, upon removal from the clutch, to decide whether it can be reused or should be replaced.

Smooth engagement and disengagement of the clutch depends much on the condition of this bearing.

#### NOTE:

Thrust washer is located between the pressure plate and thrust bearing.

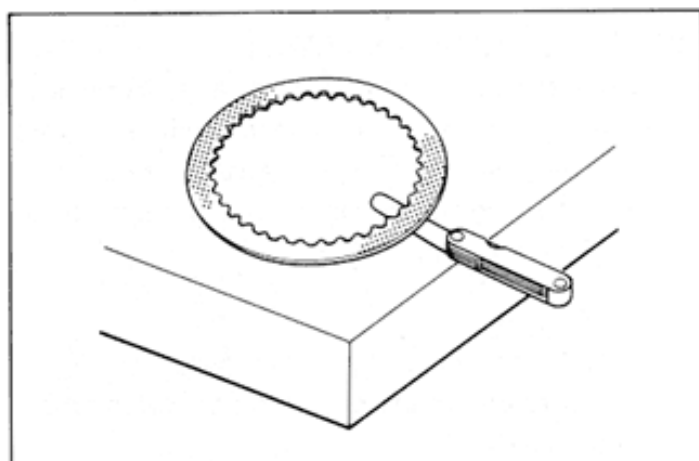

Checking distortion

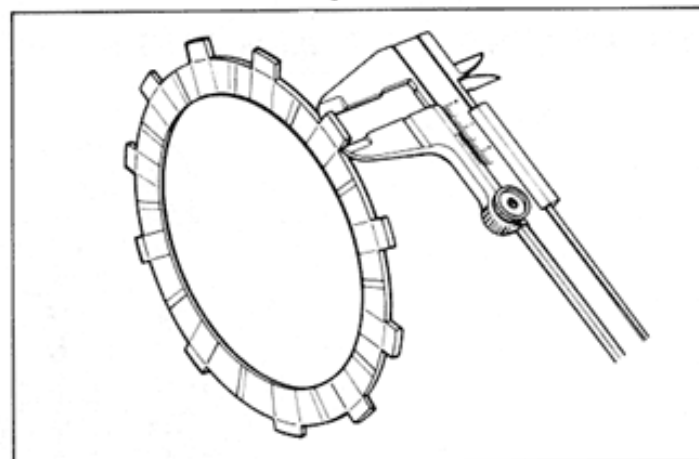

Checking claw width

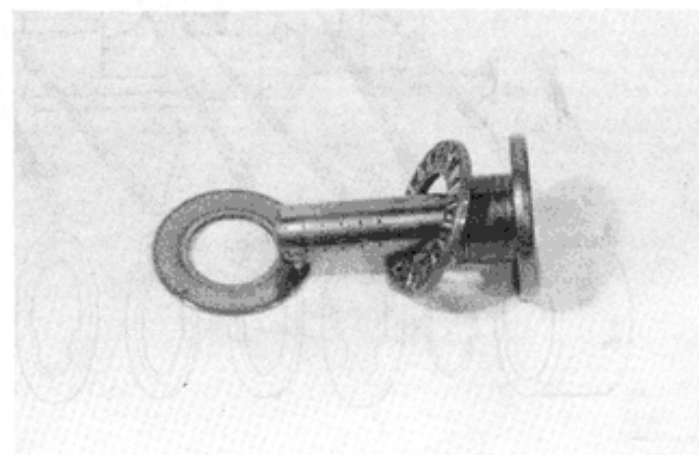
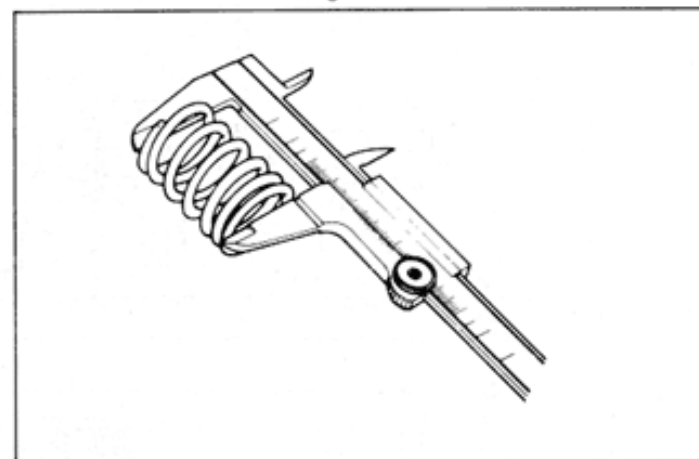

**SLEEVE HUB SPRING WASHER**

- Install the spring seat, spring, and driven plate in the clutch sleeve hub. Check that these three parts are positioned correctly as illustrated. While holding the driven plate with pliers, install the piano wire clip.

**NOTE:**

- \* Always use a new piano wire clip.
- \* Thicker driven plate is used for holding the wave washer.

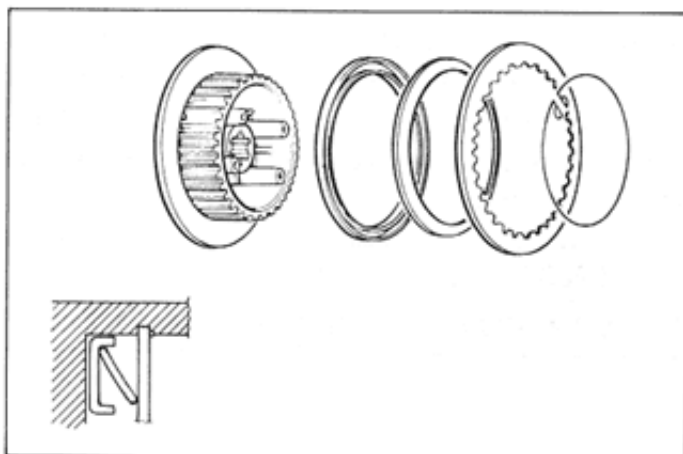
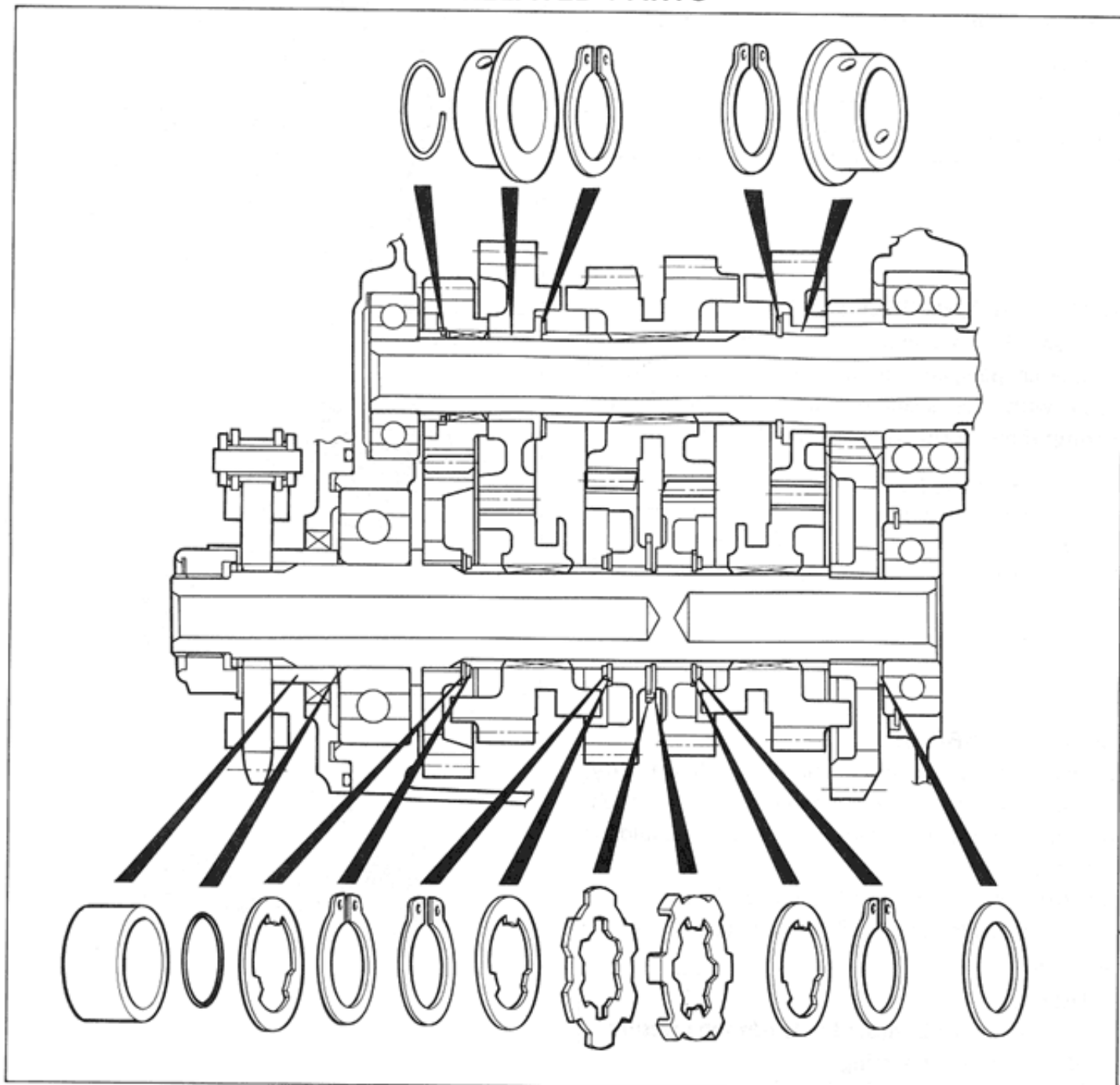
**TRANSMISSION GEARS AND RELATED PARTS**

## GEAR-SHIFTING FORK CLEARANCE

Using a thickness gauge, check the shifting fork clearance in the groove of its gear.

This clearance for each of the three shifting forks plays an important role in the smoothness and positiveness of shifting action. Each fork has its prongs fitted into the annular groove provided in its gear. In operation, there is sliding contact between fork and gear and, when a shifting action is initiated, the fork pushes the gear axially. Too much a clearance is, therefore, liable to cause the meshed gears to slip apart.

If the clearance checked is noted to exceed the limit specified, replace the fork or its gear, or both.

09900-20803	Thickness gauge
-------------	-----------------

### Shift fork – groove clearance

Service Limit	0.50 mm
---------------	---------

### Shift fork groove width

Standard	5.0 – 5.1 mm
----------	--------------

### Shift fork thickness

Standard	4.8 – 4.9 mm
----------	--------------

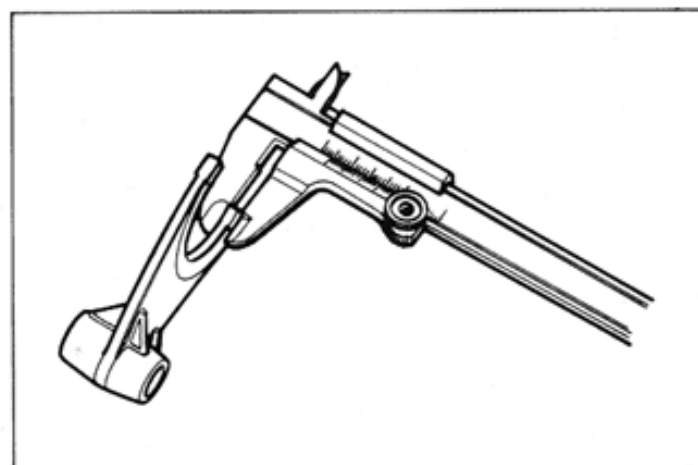
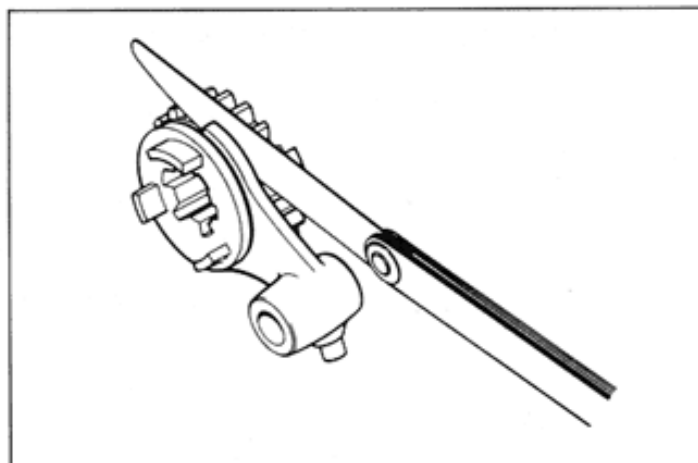

## COUNTERSHAFT DISASSEMBLY

- Using a snapping pliers, slide the circlip ① to the right side.
- Slide the top and 2nd drive gears to the right side.

09900-06104	Snapping pliers
-------------	-----------------

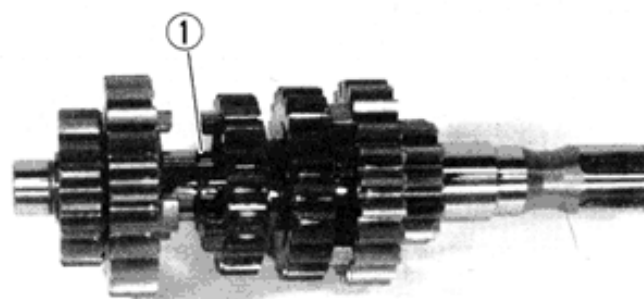

- Using a screw driver, remove the clip ① from the countershaft.

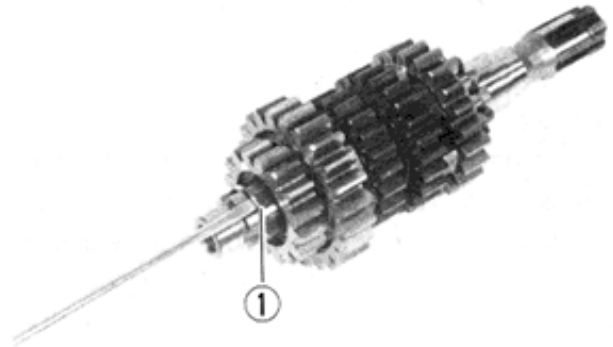

- Remove the 2nd drive gear ②, Top drive gear ③ from the countershaft.
- Remove the other gears from the countershaft.

09900-06107	Snapping pliers
-------------	-----------------

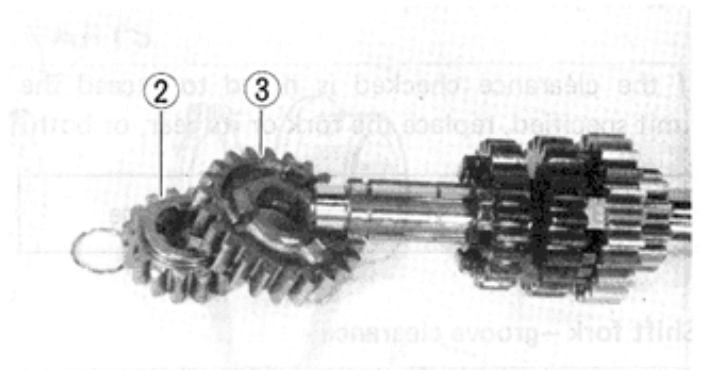

### DRIVE SHAFT DISASSEMBLY

- Remove the washer ④, 2nd driven gear ⑤, and top driven gears ⑥ from the drive shaft.

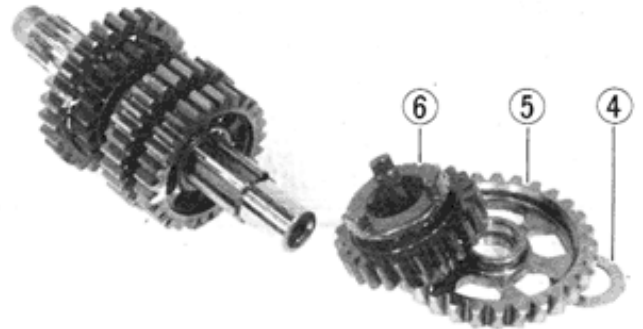

- After removing the 3rd driven gear, remove the pair of lock washers ⑦ and ⑧.

**NOTE:**  
When reinstalling the lock washers ⑦ and ⑧, insert lock washer ⑧ into the drive shaft, and turn and fit it into the groove. Then fit the lock washer ⑦ in the lock washer ⑧.

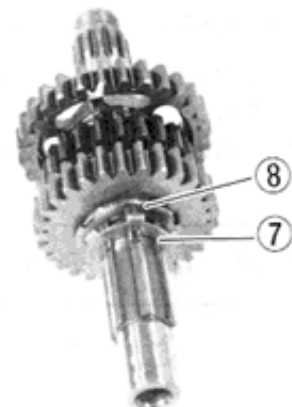

- When mounting circlip, pay attention to the direction of the circlip. Fit it to the side where the thrust is as shown in the figure with the rounded side against the gear surface.

**NOTE:**

Always use a new circlip.

**CAUTION:**

Never reuse a circlip after a circlip has been removed from a shaft. A used circlip should be discarded and a new circlip must be installed. When installing a new circlip, care must be taken not to expand the end gap larger than required to slip the circlip over the shaft. After installing a circlip, always insure that it is completely seated in its groove and securely fitted.

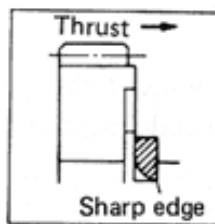

## ENGINE REASSEMBLY

This engine is reassembled by carrying out the steps of disassembly in the reverse order, but there are a number of steps which demand special descriptions or precautionary measures.

**NOTE:**

Apply engine oil to each running and sliding part before reassembling.

- Apply SUZUKI super grease "A" to the lip of oil seals lightly.

**CAUTION:**

Do not apply grease to the exhaust valve.

99000-25010	SUZUKI super grease "A"
-------------	-------------------------

- Install each exhaust valve to the respective cylinders.
- Turn the exhaust valve and set it open.
- The protrusion ① of the valve opening positions on the cylinder bore side so that both valves engage into each other at the valve ends ②.

- Connect the shorter cables to the exhaust valve pulley which has a stopper ③ and install the pulley to the exhaust valve of the No. 4 cylinder.
- Align the line mark ④ on the pulley with the index mark ⑤ and exhaust valve is opened.
- Tighten the exhaust valve pulley bolt to the specified torque.

Tightening torque	4 – 7 N·m (0.4 – 0.7 kg-m)
-------------------	-------------------------------

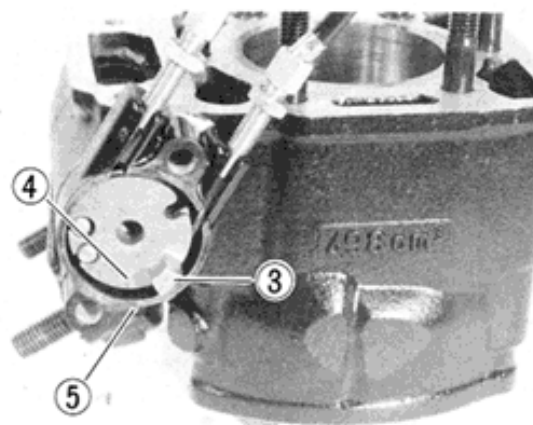
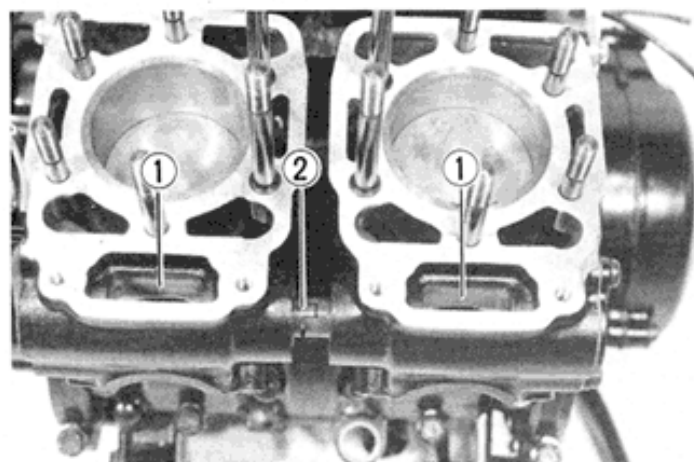
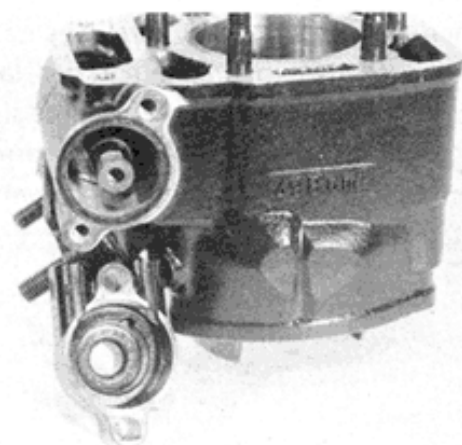

- Connect the longer cables to the pulley and install the pulley to the exhaust valve of the No. 2 cylinder in the same manner as No. 4 cylinder.

- ① : Line mark  
② : Index mark

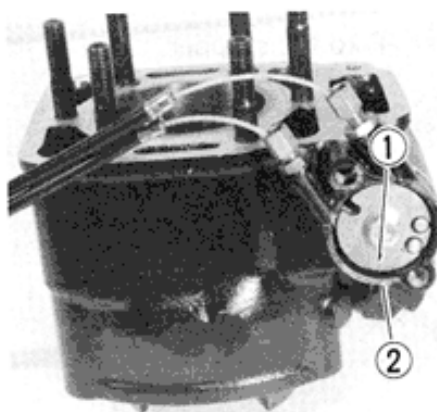

- Apply thread lock 1342 to the bearing stopper screws ③.

99000-32050	Thread lock 1342
-------------	------------------

- Install the gearshift cam to the transmission case cover.
- Install the gearshift cam stopper pins.

**NOTE:**

Install the longer pin to the neutral position ④ of the gearshift cam stopper.

- Install the gearshift cam stopper and spring. Check that the gearshift cam stopper moves smoothly.

Tightening torque	15 – 23 N·m (1.5 – 2.3 kg·m)
-------------------	---------------------------------

- Position the gearshift cam stopper to the neutral position ④.
- Align the recess ⑤ of the retainer plate with the neutral stopper pin and install the plate with a screw.
- Apply thread lock "1333" to the retainer plate screw and gearshift cam stopper bolt.

99000-32020	Thread lock "1333"
-------------	--------------------

- Slide the washer ⑥ on the kick starter shaft.

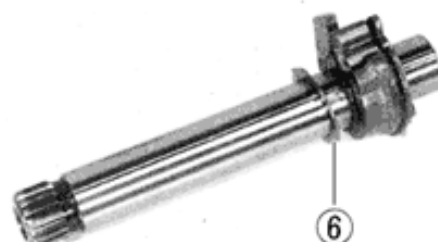
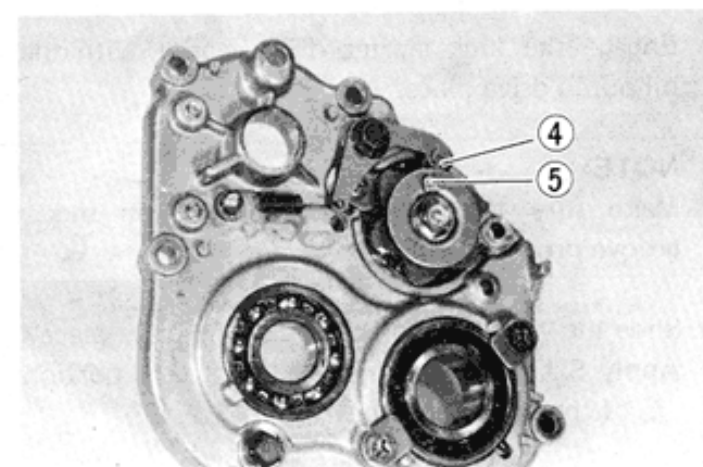
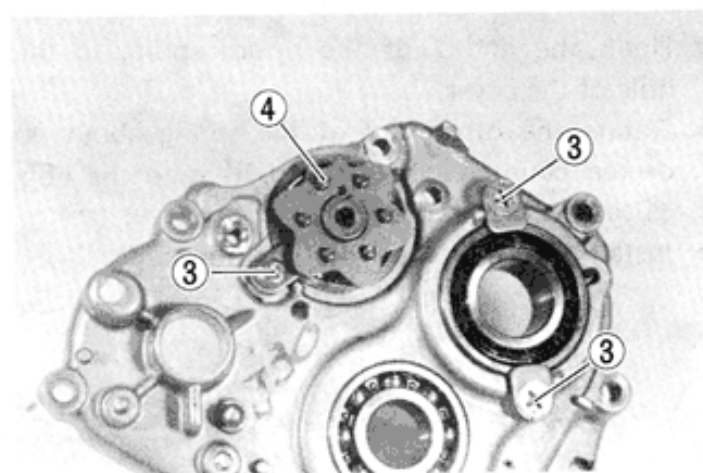

- Set the kick starter ① to the stopper.

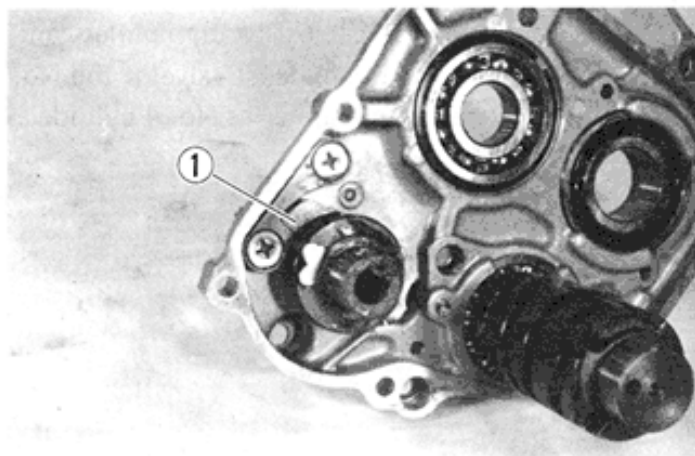

- Hook the end ② of the return spring to the hole of the cover.
- Rotate the other end of the spring about 90 degree counterclockwise and fit it to the hole ③ of the kick starter shaft.
- Install the kick starter return spring guide.

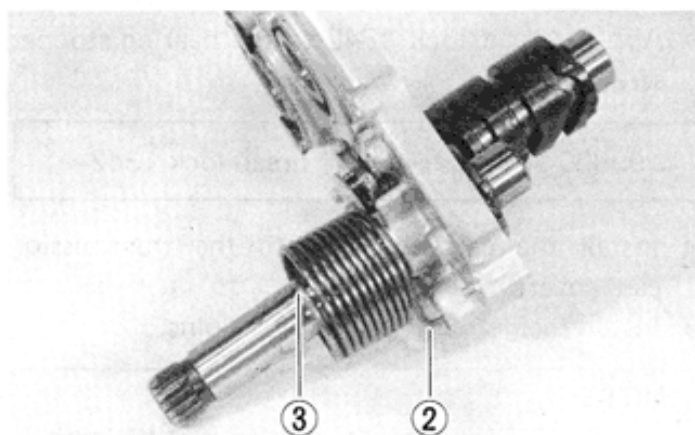

- Engage the kick starter drive gear ④ with the oil pump drive piece.

**NOTE:**  
Make sure that the circlip ⑤ seats in the groove properly.

- Slide the washer ⑥ on the oil pump drive piece.
- Apply SUZUKI Super grease "A" to the portion ⑦ of the kick starter gear.

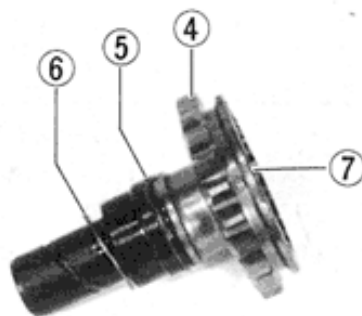

- Install the countershaft and drive shaft to the cover.

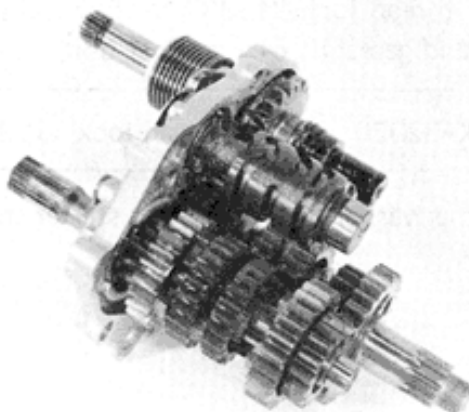

- Install the gearshift forks and fork shafts properly.
- Make sure that countershaft and drive shaft turns freely when the gears are in neutral.

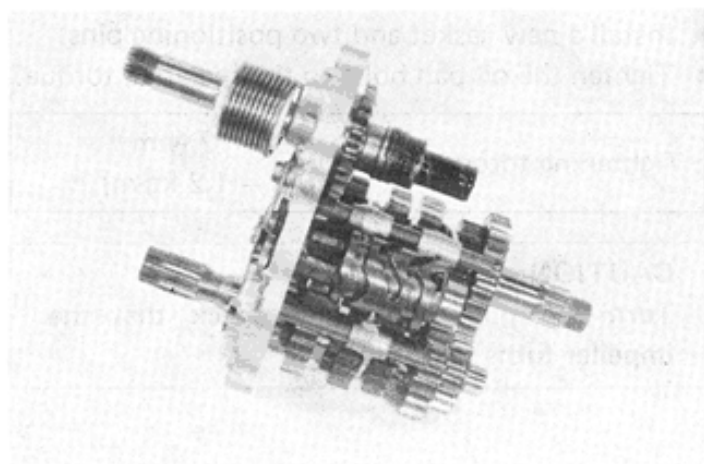

- Align the punch mark ① on the pilot driven gear with the punch mark ② on the pilot shaft.
- Install the pilot driven gear to the pilot shaft.

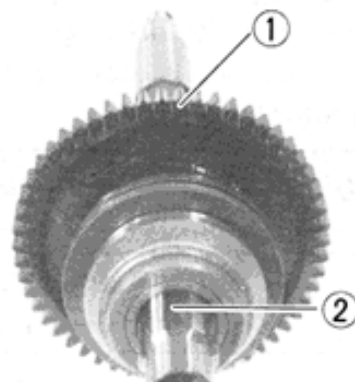

- Install the pilot shaft and bearing to the lower crankcase.

**NOTE:**

When installing the bearing to the lower crankcase, tap the bearing lightly with a plastic hammer.

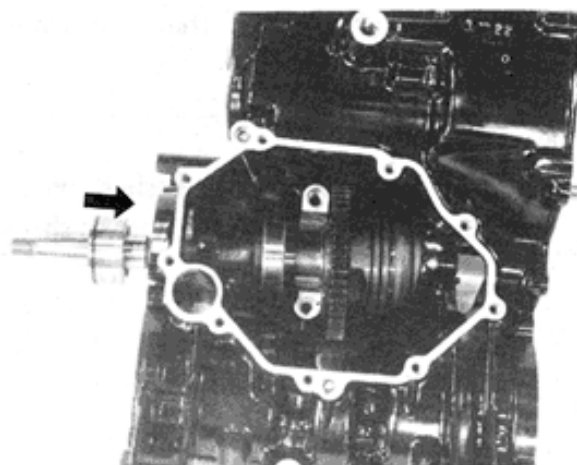

- Face the arrow mark ③ on the bearing holder forward.
- Tighten the bearing holder bolts to the specified torque.

Tightening torque

20 – 24 N·m  
(2.0 – 2.4 kg·m)

**CAUTION:**

Make sure that the pilot shaft turns smoothly.

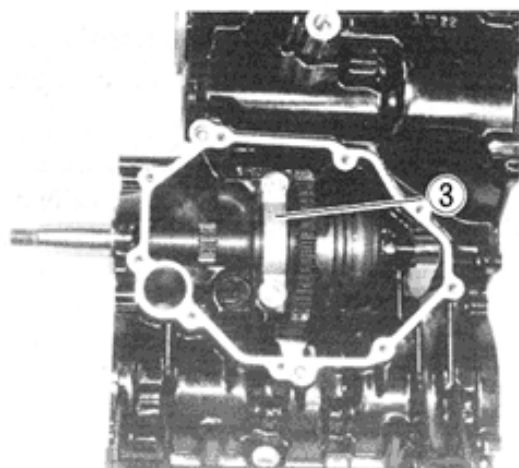

- Install a new gasket and two positioning pins.
- Tighten the oil pan bolts to the specified torque.

Tightening torque	8 – 12 N·m (0.8 – 1.2 kg-m)
-------------------	--------------------------------

**CAUTION:**  
Turn the pilot shaft and check that the impeller turns smoothly.

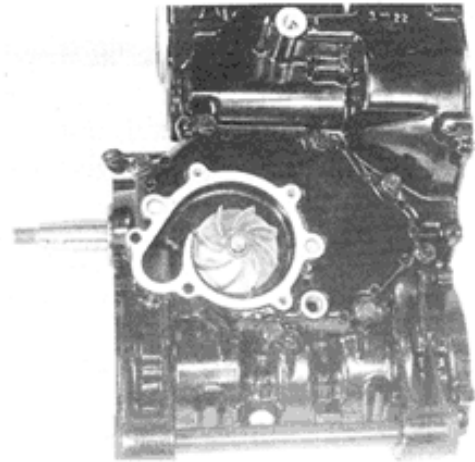

- Install the primary drive gear, wave washer to the pilot shaft.
- Tighten the primary drive gear bolt to the specified torque while holding the magneto rotor with rotor holder.

09930-40113	Rotor holder
-------------	--------------

Tightening torque	90 – 110 N·m (9.0 – 11.0 kg-m)
-------------------	-----------------------------------

- After installing the primary drive gear, turn the pilot shaft and check that the water pump impeller turns smoothly.

**NOTE:**  
When installing the wave washer, be sure to face its concaved side to the gear as shown.

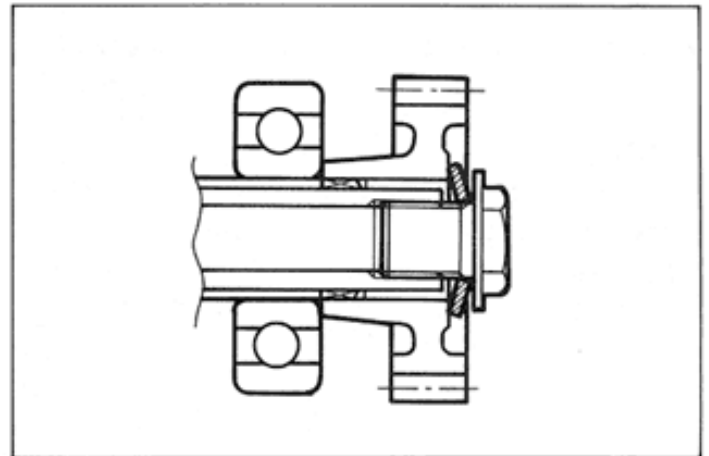
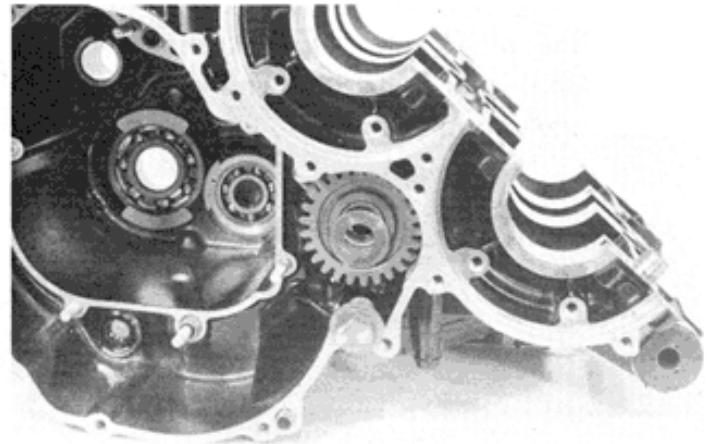

- Install a new O-ring and two positioning pins.
- Tighten the water pump cover bolts to the specified torque.

Tightening torque	8 – 12 N·m (0.8 – 1.2 kg-m)
-------------------	--------------------------------

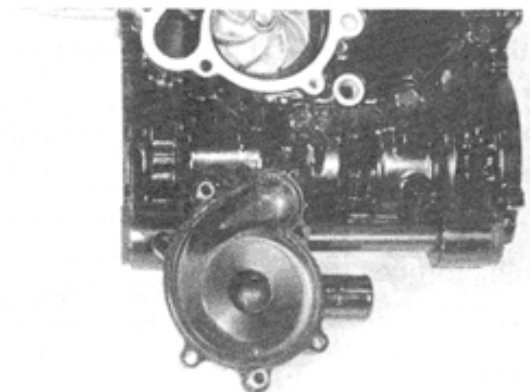

- Install the transmission assembly to the lower crankcase.

**NOTE:**

Apply transmission oil to the gears, shafts and bearings.

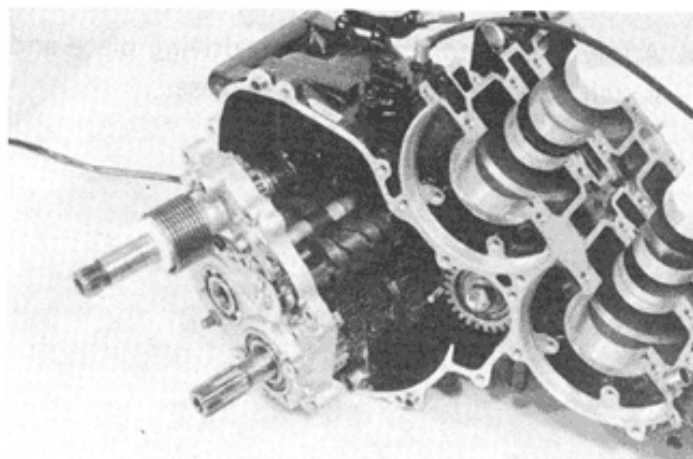

- Tighten the case nuts to the specified torque.
- Each nut needs the lock washer.
- After tightening the nuts, positively bend the locking tab.

**NOTE:**

Install the gearshift cam stopper plate to the position (A).

Tightening torque	8 – 12 N·m (0.8 – 1.2 kg·m)
-------------------	--------------------------------

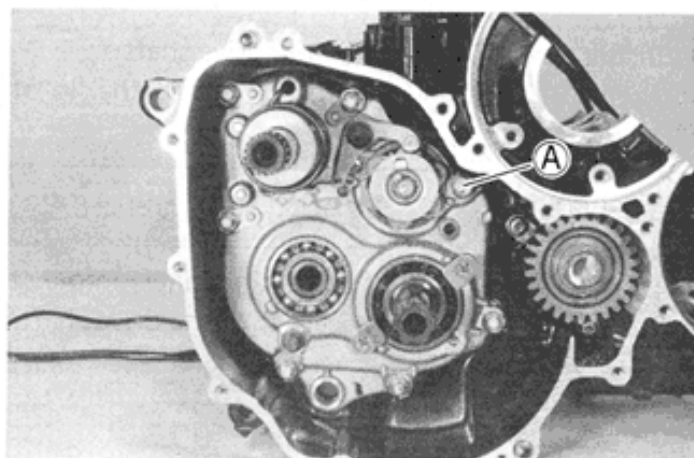

- Install the gearshift shaft to the proper position.

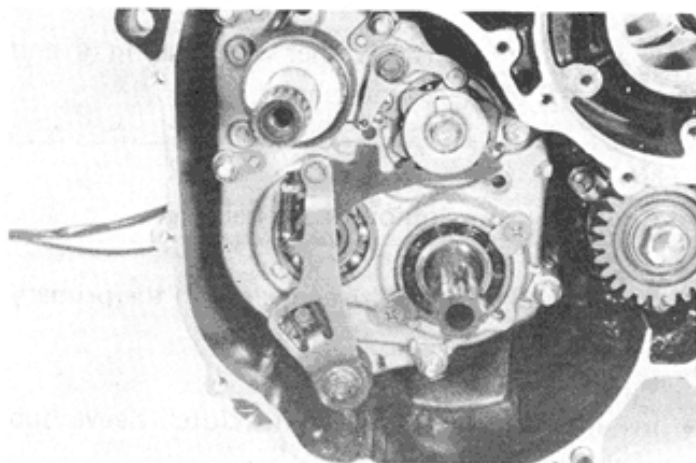

- Install the neutral switch spring, switch contact and switch body.

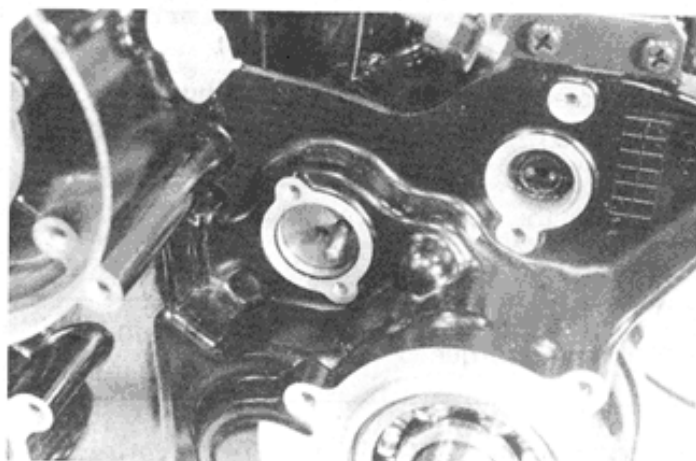

- Apply grease to the oil pump driving piece and install the oil pump to the crankcase.
- Use a new O-ring.

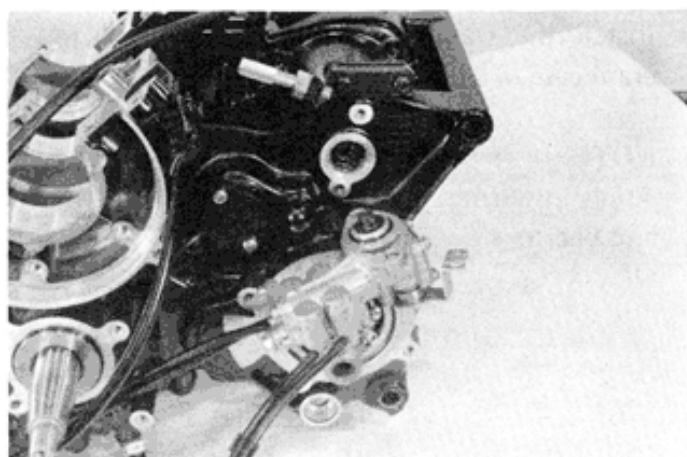

- Install a new O-ring ① to the drive shaft.
- Apply SUZUKI super grease "A" to the lip of oil seal ②.

99000-25010	SUZUKI super grease "A"
-------------	-------------------------

- Install a new O-ring ③ to the inner sprocket cover and install the spacer ④ to the drive shaft.

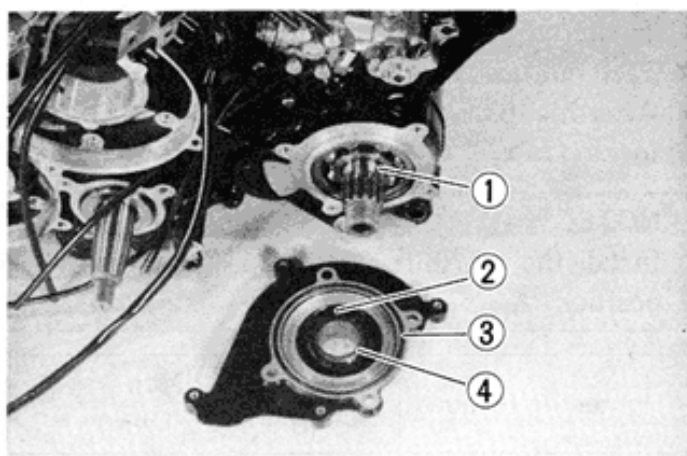

- Install the thrust washer ⑤, bearing ⑥ and spacer ⑦ to the countershaft.

**NOTE:**  
Apply transmission oil to the bearing.

- Engage the primary driven gear with the primary drive gear.
- Install the thrust washer and clutch sleeve hub to the countershaft.

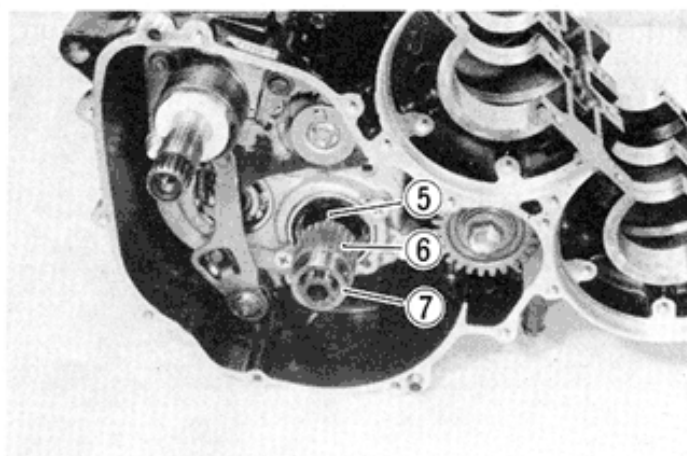

**NOTE:**  
For assembling the clutch sleeve hub, refer to page 3-31.

- Tighten the clutch sleeve hub nut to the specified torque.

Tightening torque	50 – 70 N·m (5.0 – 7.0 kg·m)
-------------------	---------------------------------

- Bend the lock washer positively.

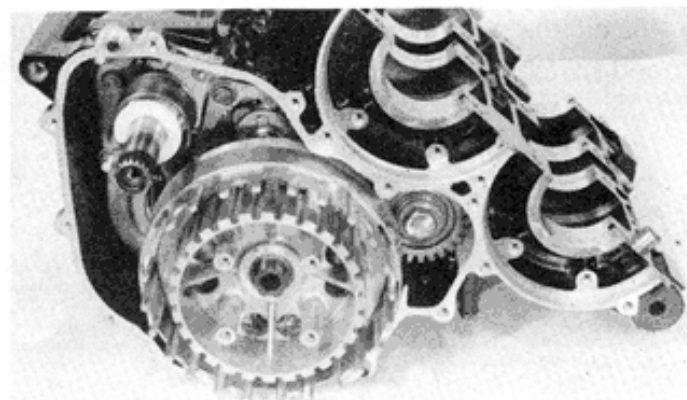

- Insert clutch drive plate and driven plate one by one into sleeve hub in the prescribed order, cork plate first.

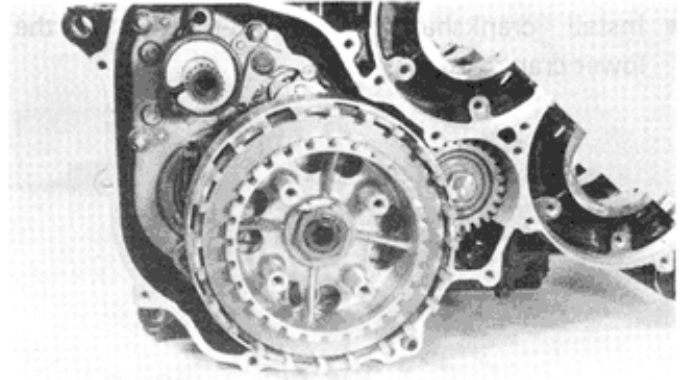

- Insert clutch release rack, bearing and thrust washer into pressure plate, and install clip ① in groove of clutch release rack.

**NOTE:**

Thrust washer is located between the pressure plate and thrust bearing.

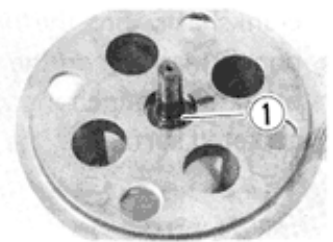

- Fit the pressure plate into sleeve hub so that there is no clearance between cork plate and pressure plate.
- Tighten clutch spring bolts in the order shown in photo.

**NOTE:**

Tighten clutch spring bolts in the manner indicated, tightening them by degrees until they attain a uniform tightness.

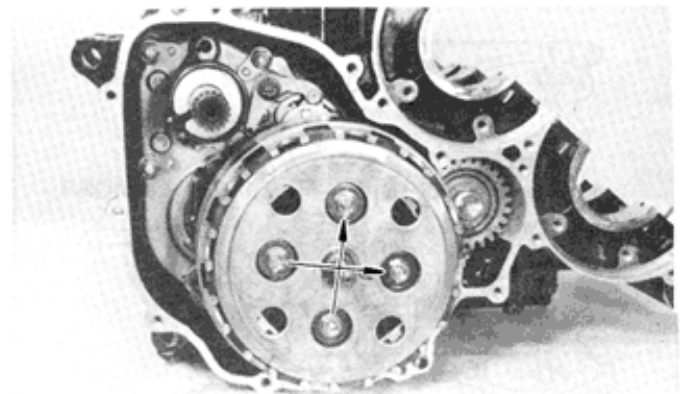

Tightening torque

8 – 12 N·m  
(0.8 – 1.2 kg·m)

- Install a new gasket and positioning pins.
- Apply grease to the lip of oil seal of the kick starter shaft.
- Engage the teeth of clutch release rack with those of pinion gear at the clutch cover side, and replace clutch cover. Make sure that the rack and pinion gears engage positively. To install cover, tap lightly with plastic hammer, and tighten screws.

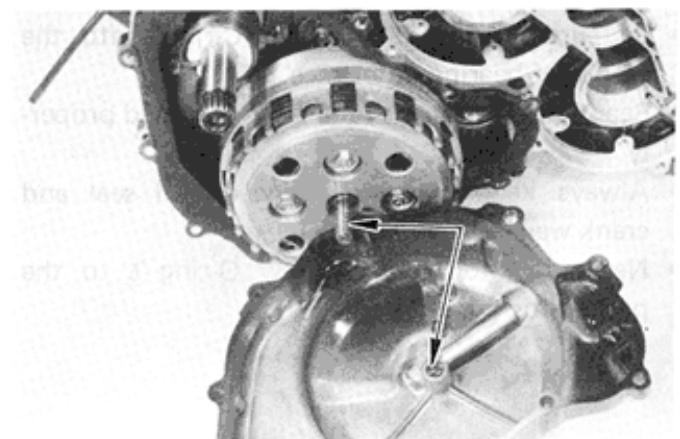

- Install crankshaft bearing C-rings ① to the lower crankcase.

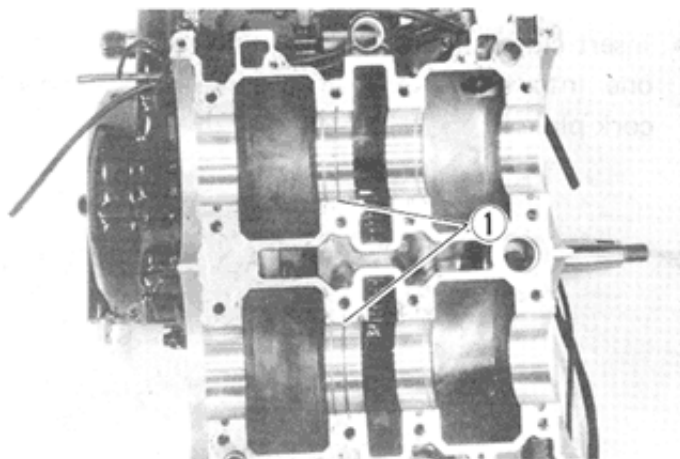

- Temporarily mount rotor with the key on the pilot shaft.
- Turn pilot shaft and bring the engraved line ② on rotor to the index line ③ of lower crankcase.
- Hold the pilot shaft in position and mount two crankshafts on the lower crankcase so that punch mark ④ on the pilot drive gear meet each other and punch-marked teeth flush with the gasketed surface of the lower crankcase.

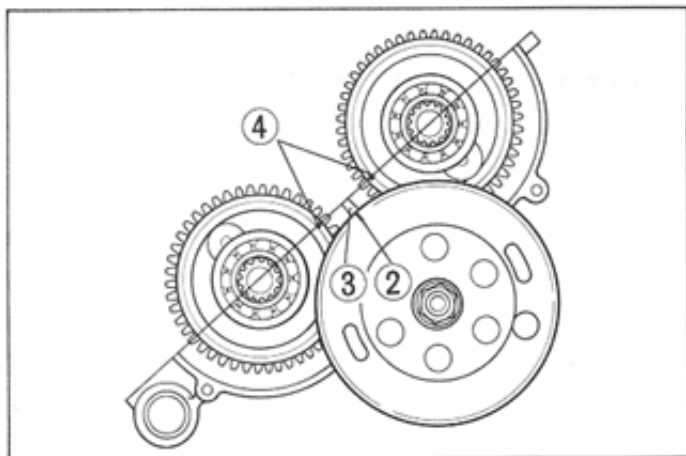
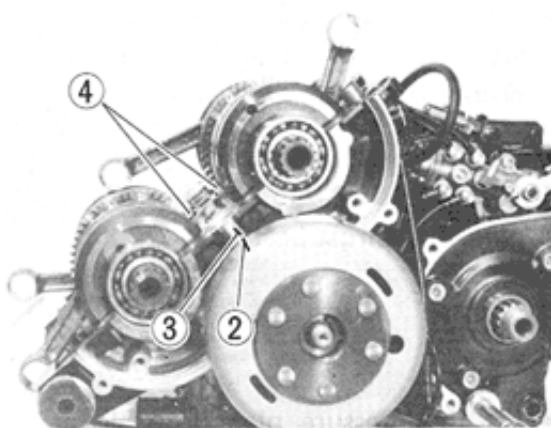

- Be sure to install the two C-rings into the groove of bearing outer race.
- Bearing dowel pins should be positioned properly.
- Always keep clearance between oil seal and crank web.
- Never fail to install a new O-ring ⑤ to the proper position.

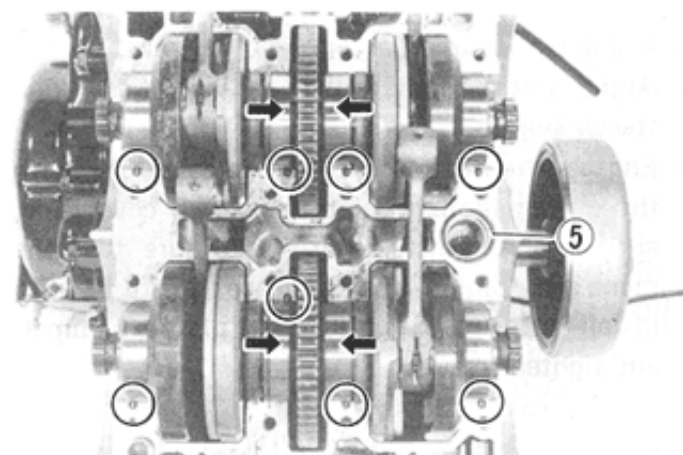

- Clean the mating surfaces of the crankcases before matching the upper and lower ones.
- Install two positioning pins.
- Apply SUZUKI BOND No. 1207B to the mating surface of the upper crankcase in the following procedure.

99000-31140

SUZUKI Bond No. 1207B

**NOTE:**

Use of SUZUKI BOND No. 1207B is as follows:

- \* Make surfaces free from moisture, oil, dust and other foreign materials.
  - \* Spread on surfaces thinly to form an even layer, and assemble the crankcases within few minutes.
  - \* Apply to distorted surfaces as it forms a comparatively thick film.
- When securing the lower crankcase, tighten the 8-mm bolts and the 6-mm bolts in the ascending order of numbers assigned to these bolts, tightening each bolt a little at a time to equalize the pressure. Tighten all the securing bolts to the specified torque values.
  - Install the copper gaskets to the positions that are indicated by asterisk (\*) mark.

**Tightening torque**

		N·m	kg·m
6 mm bolt		9 – 13	0.9 – 1.3
8 mm bolt	Initial	12 – 16	1.2 – 1.6
	Final	20 – 24	2.0 – 2.4

- Install a new gasket to the inner valve seat.

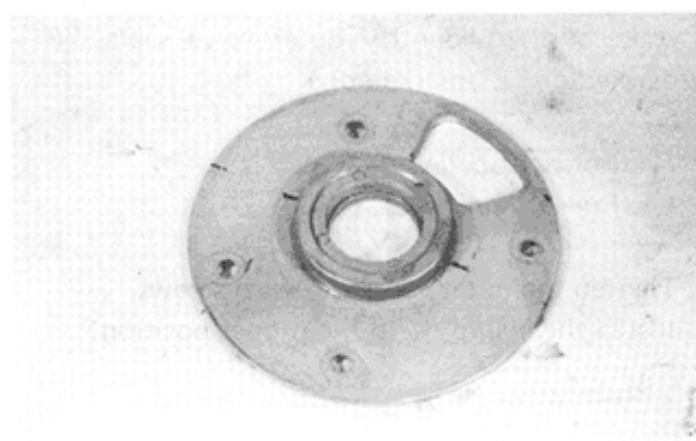
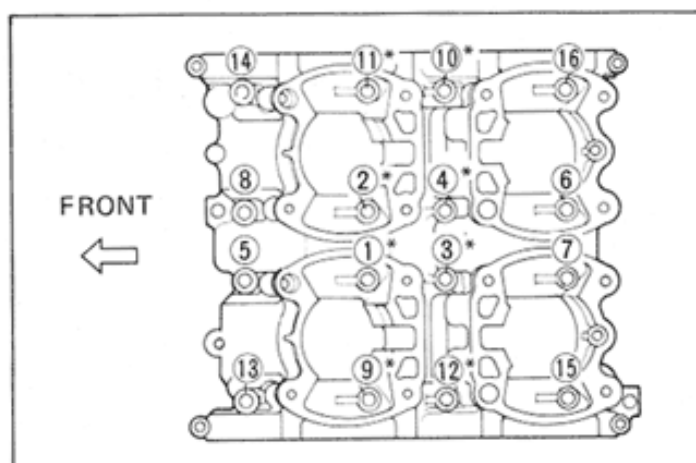
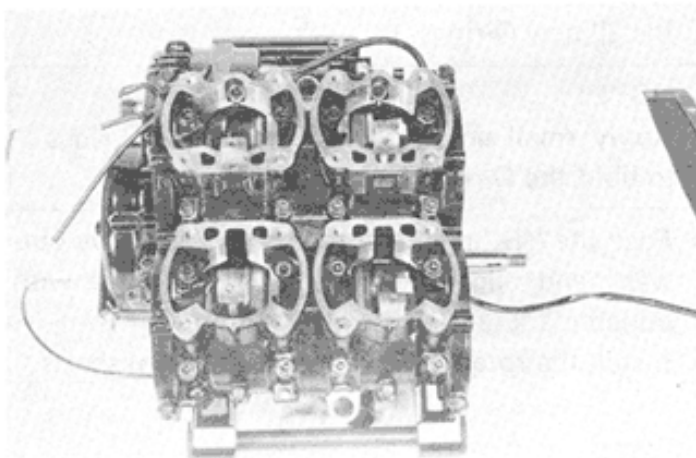
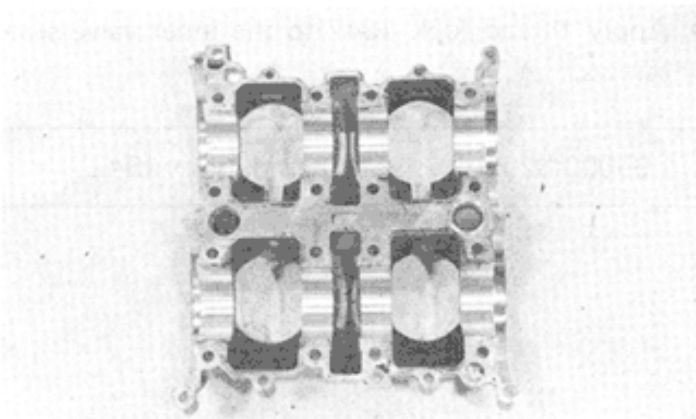

- Apply thread lock 1342 to the inner valve seat screws.

99000-32050	Thread lock "1342"
-------------	--------------------

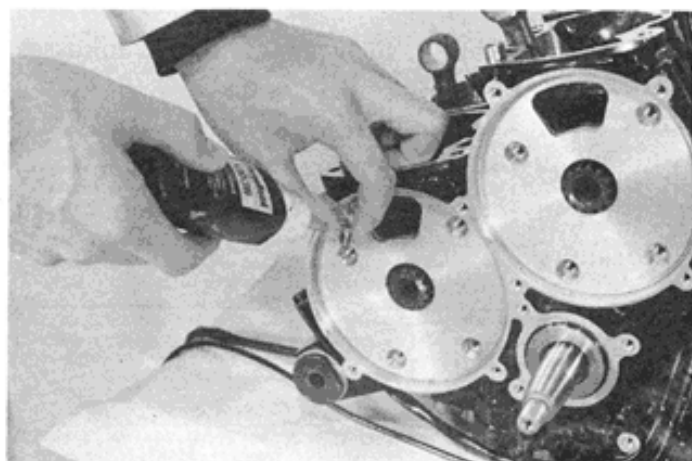

- Install new O-rings ①.

**NOTE:**  
Apply small amount of grease to the O-rings to hold the O-rings in position.

- Face the "R" mark on the rotary disc valve outward and align the cut ② of the valve with punch mark ③ on the crankshaft end.
- Install the rotary disc valves to the crankshafts.

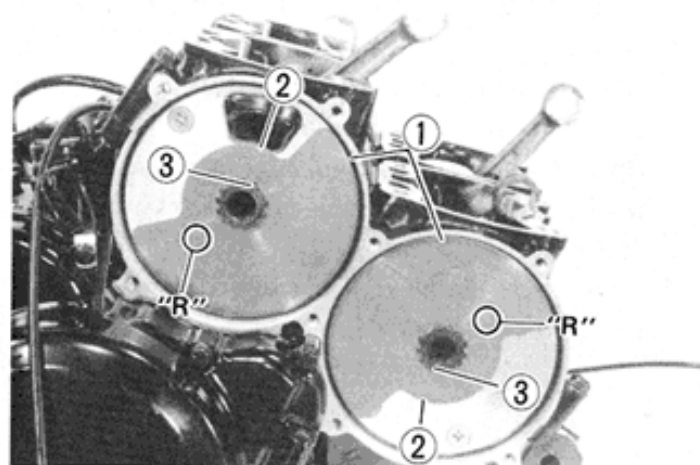

**NOTE:**  
For the left cylinders, face the "L" mark of the valve outward.

- Apply engine oil to the valve seat and rotary disc valves.

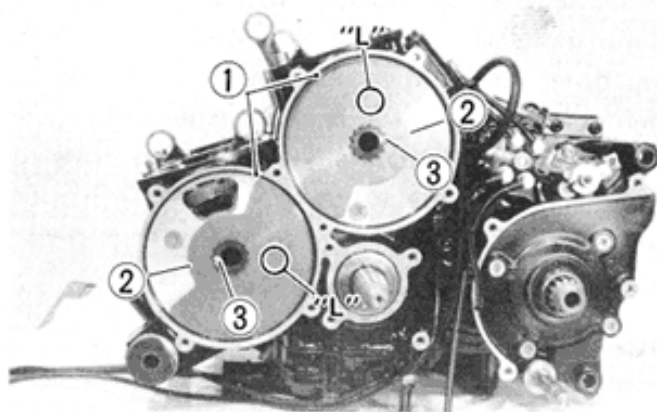

- Make sure to identify outer valve seats, "R"-marked or "L"-marked one.

R : For right cylinders  
L : For left cylinders

- Tighten the outer valve seat with screws.
- Install the clamp ④ to the proper position.

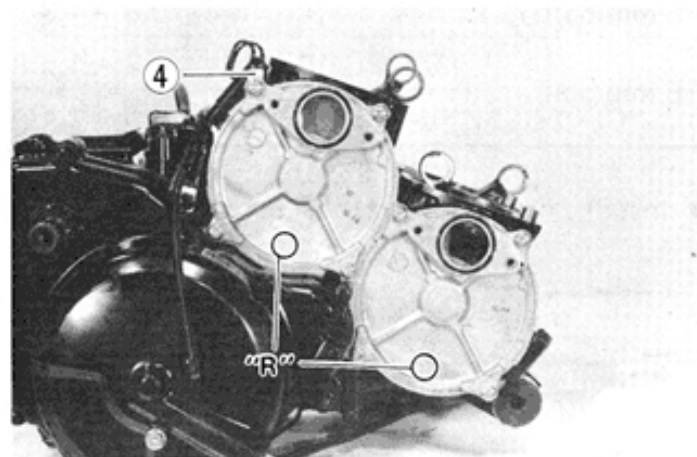

Install the two clamps to the proper positions.

- Install the magneto inner cover and magneto stator.
- Apply thread lock "1342" to the stator screws.

99000-32050	Thread lock "1342"
-------------	--------------------

- Route the stator lead wire properly.

- Degrease the tapered portion of the rotor and also the crankshaft. Use non-flammable cleaning solvent to wipe off the oily or greasy matter to make them completely dry.
- Align the key groove with the key and install the rotor to the crankshaft.
- Secure the rotor by tightening the nut to the specified torque.
- Apply thread lock 1324 to the nut.

99000-32120	Thread lock "1324"
-------------	--------------------

Tightening torque	120 – 140 N·m 12.0 – 14.0 kg·m
-------------------	-----------------------------------

- Install a rubber seal properly and tighten the magneto cover screws.

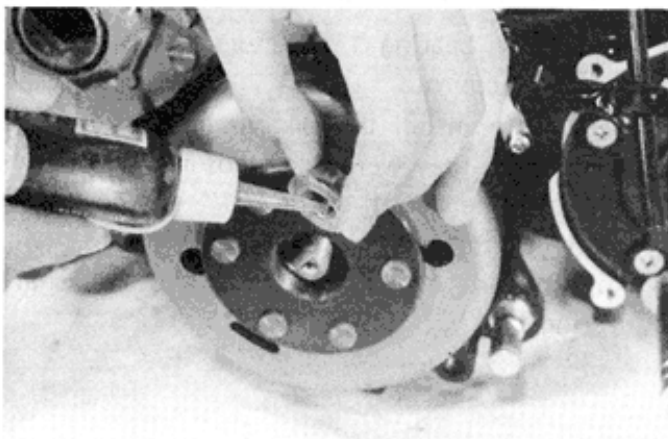
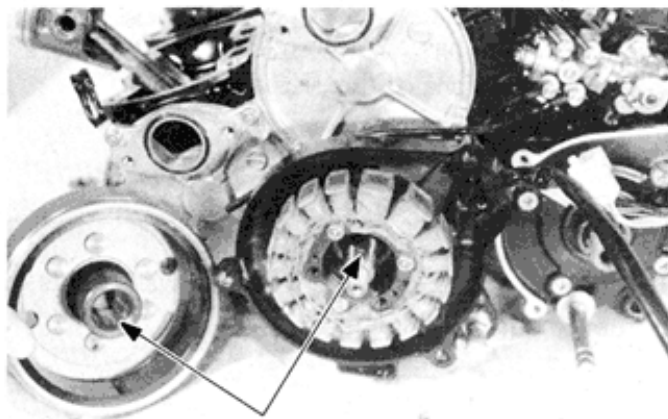
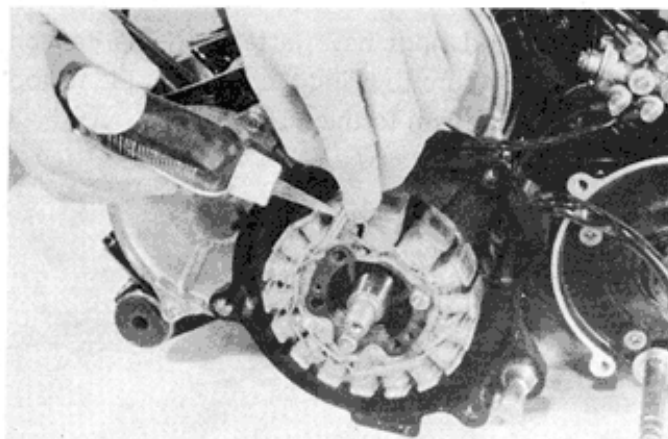
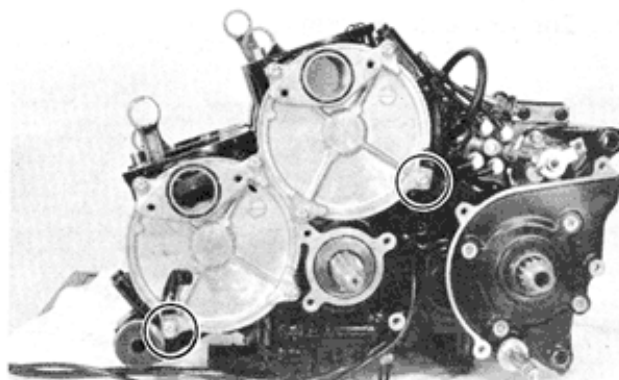

- Mount the piston rings in the order of expander ring, 2nd ring and top ring.

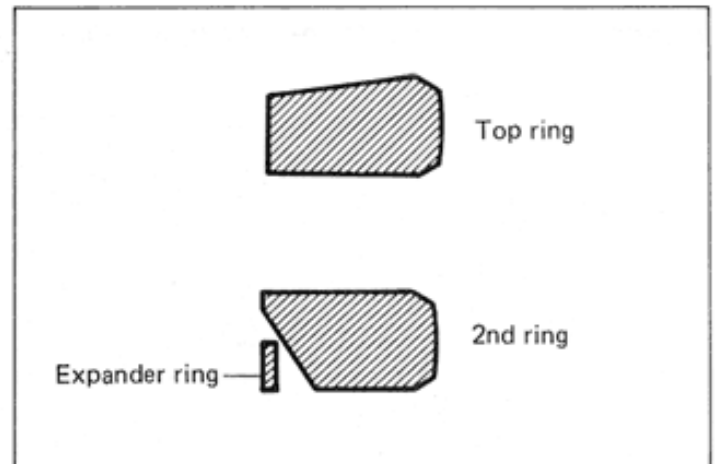

- Top and 2nd rings have letter "T" marked on the side. Be sure to bring the marked side to top when fitting them to the piston.

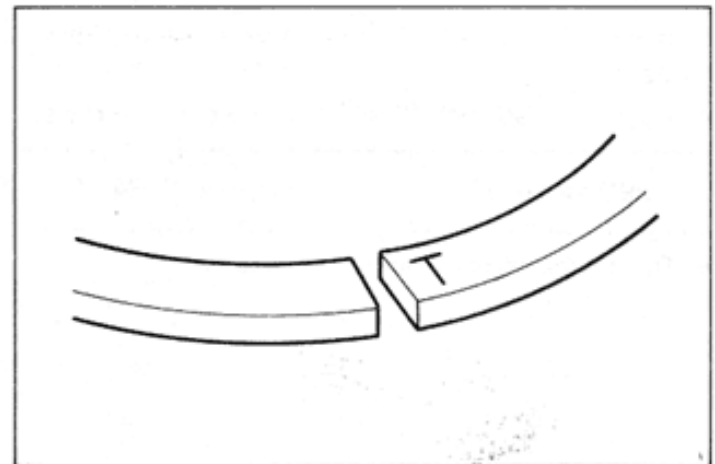

- Each piston has a letter mark "F" or "R" on the inner surface of the piston skirt.

- "F" : For front cylinders
- "R" : For rear cylinders

- The arrow mark on the piston side wall points to the exhaust port side.

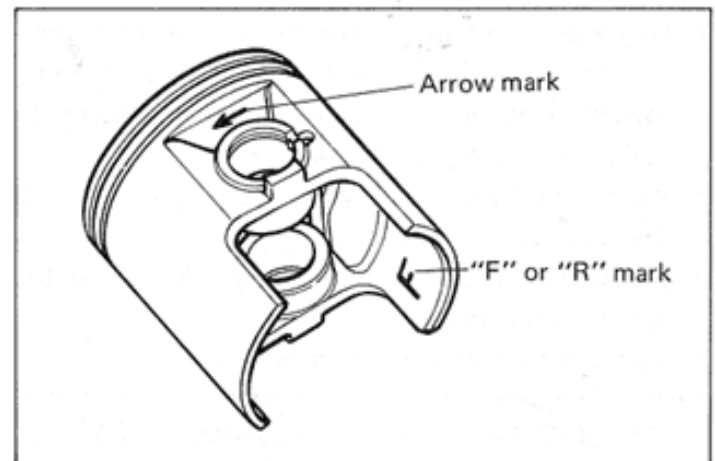

- Install the bearing ① and two thrust washers ② to the conrod.
- Be sure to install the pistons in the cylinders from which they were taken out in disassembly, refer to the letter mark, "1" through "4", scribed on the piston.
- Apply engine oil to the conrod and crankshaft bearings.

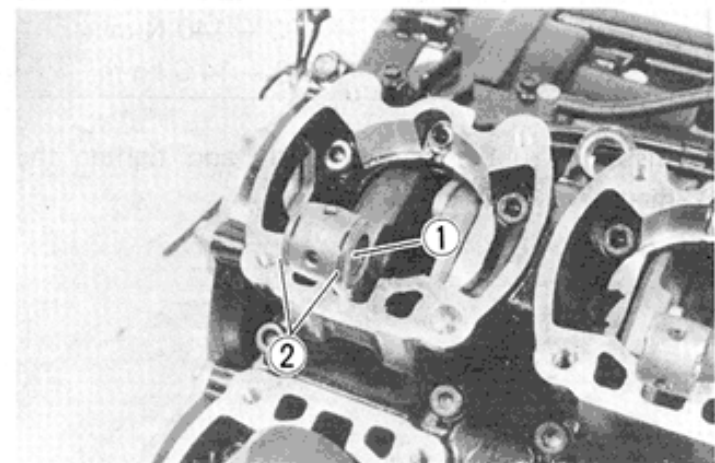

- The circlip should be mounted in such a position that the mating ends of the circlip do not coincide with the groove portion ① of the piston.
- Before inserting the piston in the cylinder, be sure to apply oil to the outer surface of the piston ring grooves.

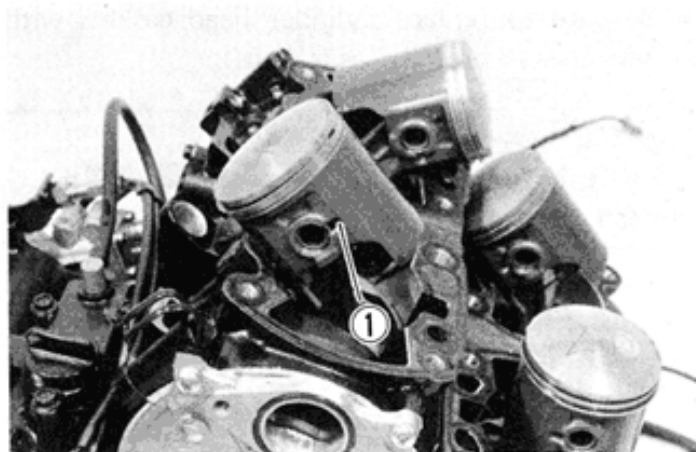

- It is extremely important that, when the piston is fed into the cylinder, each ring in place should be so positioned as to hug the locating pin.
- Install new gaskets and positioning pins properly.

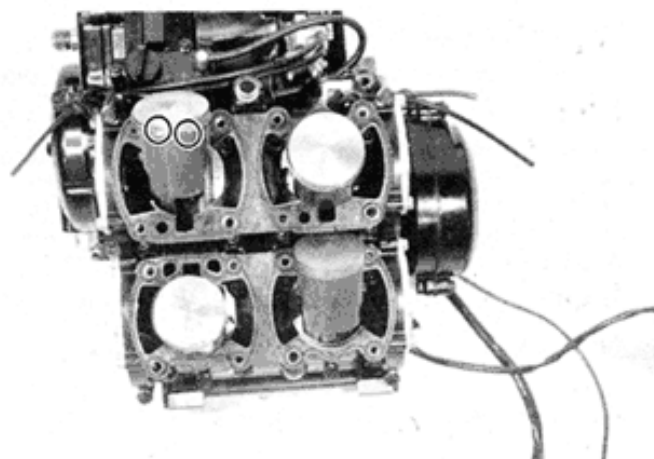

- Install the cylinders to the respective positions.
- Tighten the cylinder in the criss-cross manner to the specified torque.

Ⓐ Longer bolt

Tightening torque	23 – 27 N·m (2.3 – 2.7 kg·m)
-------------------	---------------------------------

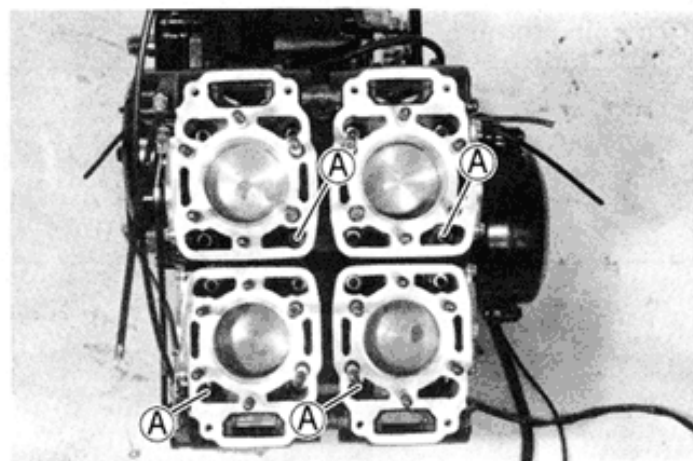

- Install new O-rings to the cylinder stud bolts Ⓑ.

Ⓑ O-ring

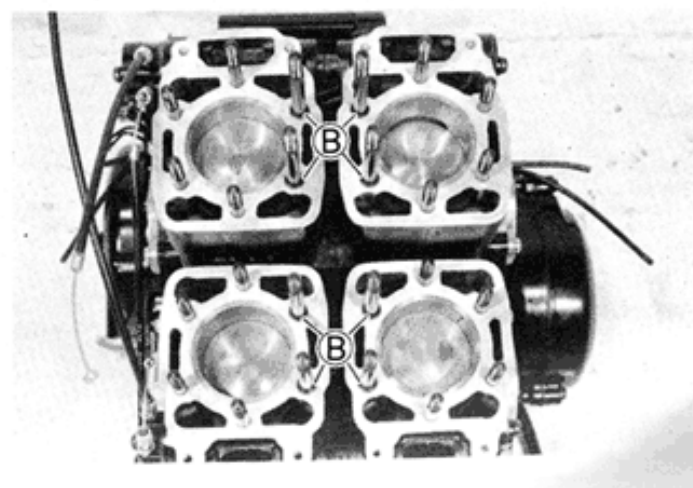

- Be sure to replace cylinder head gaskets with new ones to prevent gas leakage.

**NOTE:**

Be sure to identify the top surface of the head gasket with "UP"-mark ①.

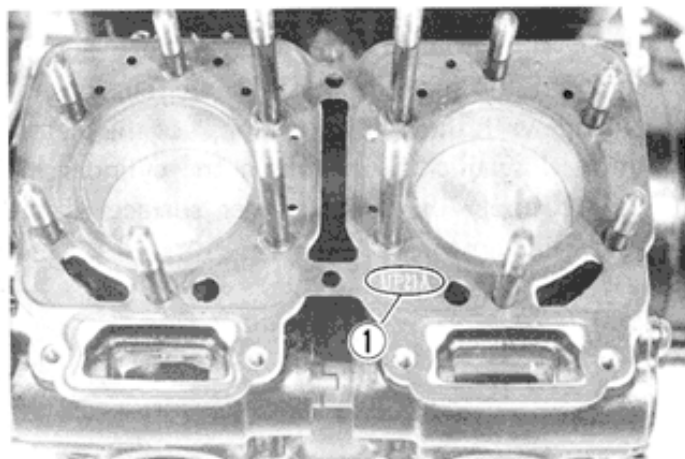

- Install the two cylinder heads.
- Install the thermostat and connect the water hose.
- Tighten the cylinder head nuts and bolts to the specified torque value.

**NOTE:**

Install copper washer with the cylinder head nuts.

- Tighten the water hose clamps.

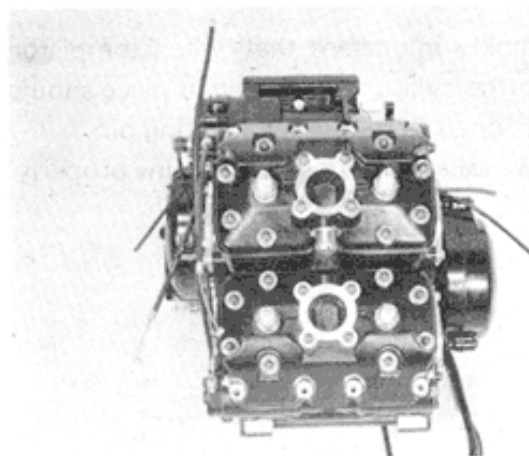

**Tightening torque**

Bolt	10 – 12 N·m (1.0 – 1.2 kg·m)
Nut	20 – 24 N·m (2.0 – 2.4 kg·m)

Tightening order of rear cylinder head

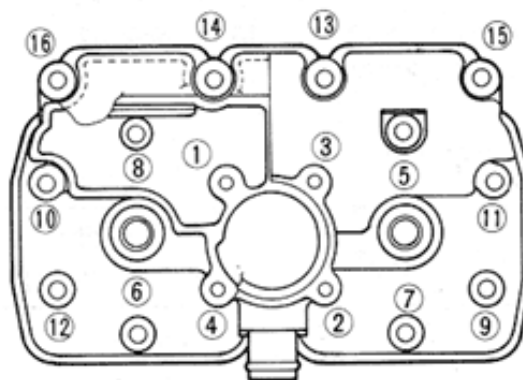

Front cylinder head

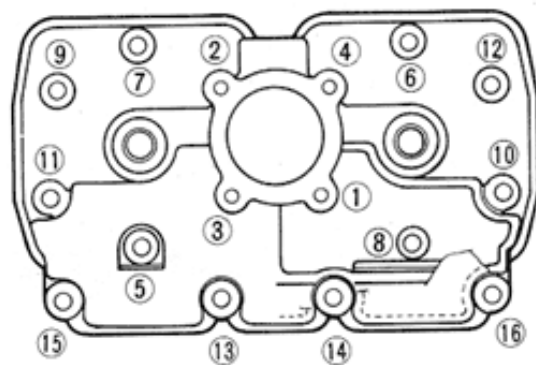

- Apply grease to the steel balls and spring, and assemble these parts.

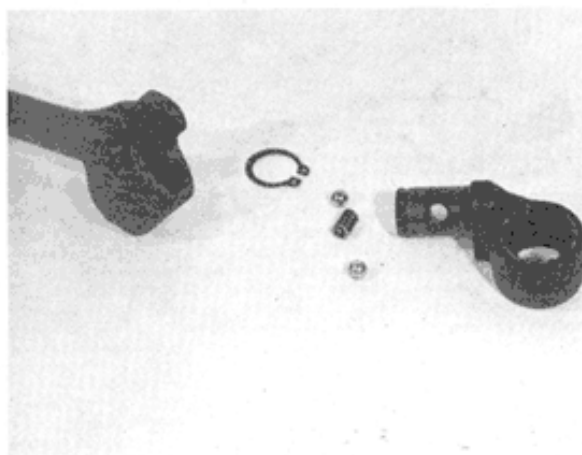

- Install the kick starter lever to the specified torque.

Tightening torque	18 – 28 N·m (1.8 – 2.8 kg·m)
-------------------	---------------------------------

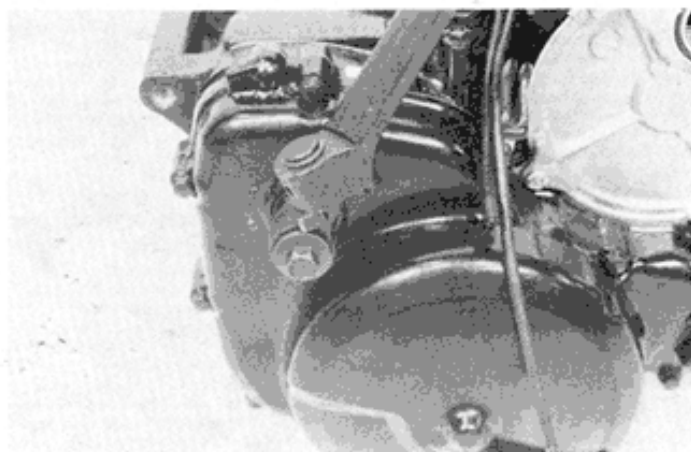

# COOLING SYSTEM

## CONTENTS

<i>COOLING SYSTEM</i> .....	4- 1
<i>COOLING SOLUTION</i> .....	4- 2
<i>RADIATOR AND WATER HOSES</i> .....	4- 3
<i>THERMOSTAT</i> .....	4- 4
<i>WATER PUMP</i> .....	4- 6
<i>WATER TEMPERATURE METER AND TEMPERATURE GAUGE</i> .....	4-11

## COOLING SYSTEM

### DESCRIPTION

The engine is cooled by coolant set in forced recirculation through jackets formed in the cylinder and head, and through the radiator. For the water pump, a high-capacity centrifugal pump is used. The radiator is a tube-and fin type made aluminum material, which is characterized by lightness in weight and good heat dissipation.

The thermostat is of wax pellet type, complete with a valve as the means of temperature-dependent control over the flow of coolant through the radiator. The valve is actuated by the temperature-sensitive wax contained in the pellet.

The thermostat is in the closed condition, so that water recirculates through the route comprising pump, engine, by-pass holes of the thermostat and radiator in the regulated condition.

As the coolant temperature rises to  $65^{\circ}\text{C}$  and the thermostat valve unseats, the normal coolant flow is established. At about  $80^{\circ}\text{C}$  of coolant temperature, the thermostat becomes completely open and the most of heat is released to the atmosphere through the radiator core.

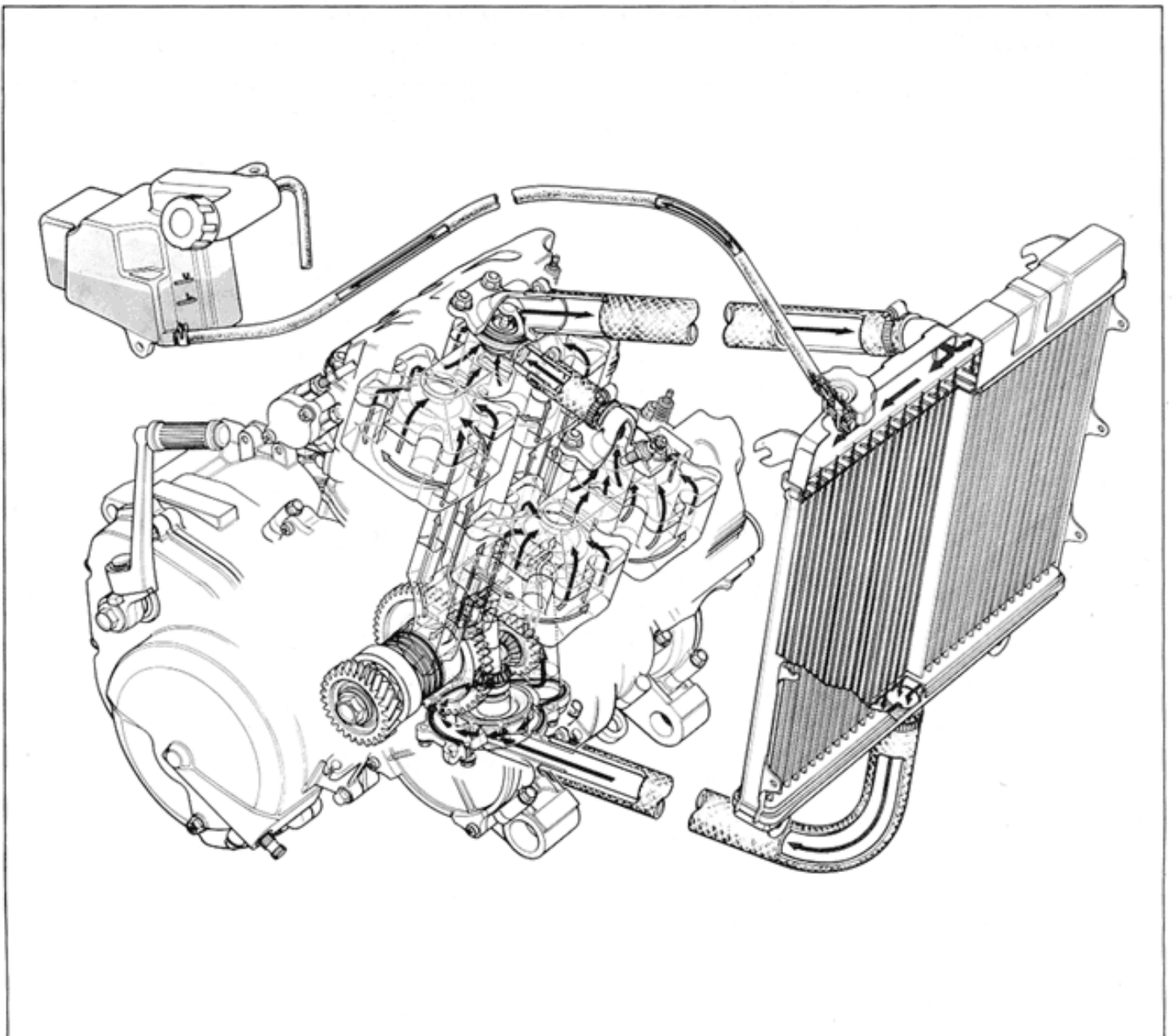

## COOLING SOLUTION

At the time of manufacture, the cooling system is filled with a 50 : 50 solution of distilled water and anti-freeze/summer coolant. This 50 : 50 mixture will provide excellent heat protection, and will protect the cooling system from freezing at temperatures above  $-31^{\circ}\text{C}$ .

If the motorcycle is to be exposed to temperatures below  $-31^{\circ}\text{C}$ , this mixing ratio should be increased up to 55% or 60% according to the Fig. 2.

**NOTE:**

Also included in the cooling solution at the time of manufacture is bar's leak material to help ensure protection against coolant leakage.

**NOTE:**

The characteristics of different anti-freezes vary. Read the label to know the protection you will have.

**CAUTION:**

Do not put in more than 60% anti-freeze or less than 50%. Do not mix different brands of anti-freeze.

### ANTI-LEAKAGE MATERIAL

The anti-freeze is characterized by very high values of permeability and accident leakage of the cooling system is highly likely. The anti-leakage substance is used to prevent such a possible leakage and every new motorcycle is serviced with "Bar's Leaks". The same material or its equivalent should be added in the radiator when coolant is changed. "Bar's Leaks" is available as one of spare parts in solid form. A suitable amount for use is 2 packs per model and in the case of a liquid anti-leakage material available in the market, 60 – 70 ml (cc) should be used.

99000-24240

Bar's Leaks

**CAUTION:**

Anti-leakage material should not be added except the time of the renewal of cooling system coolant.

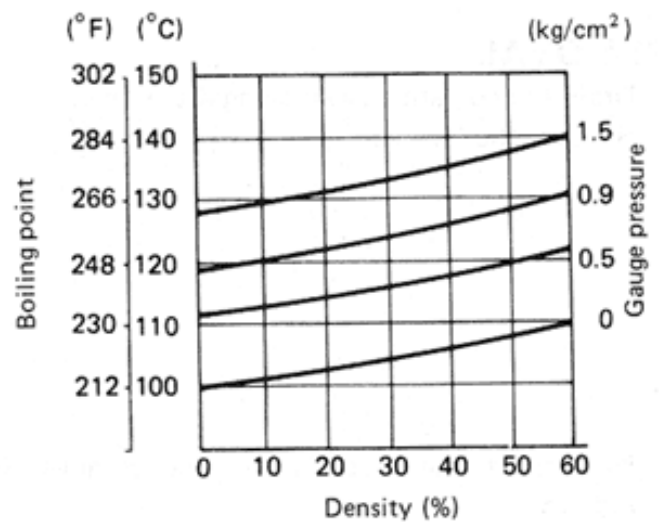

Fig. 1 Coolant density-boiling point curve.

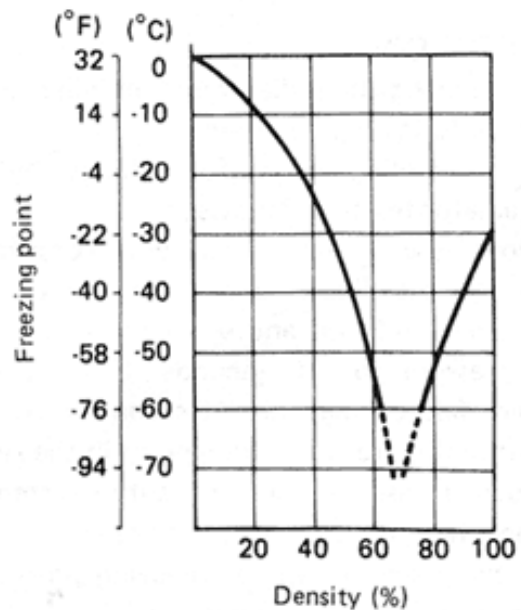
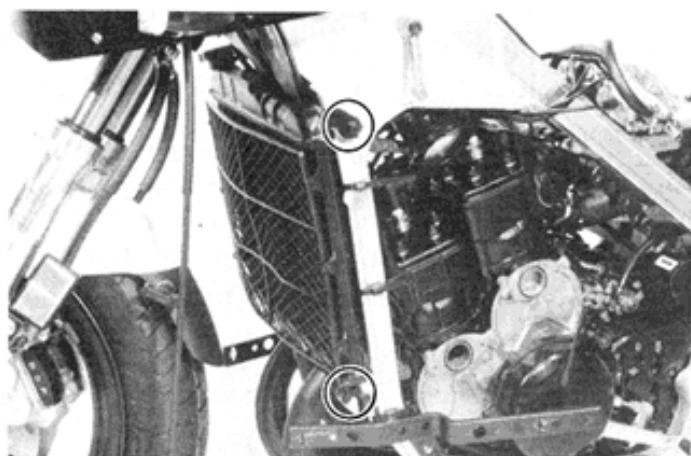

Fig. 2 Coolant density-freezing point curve.

## RADIATOR AND WATER HOSES

### REMOVAL

- Drain the coolant by removing drain plug.
  - Remove the fairings.
- 
- Disconnect the water hoses and remove the radiator.



### INSPECTION

Before removing the radiator and draining coolant, inspect the following two items.

1. Test the cooling system for tightness by using the radiator tester as follows:  
Remove the radiator cap, and connect the tester to the filler. Give a pressure of about  $1 \text{ kg/cm}^2$  (14.2 psi) and see if the system holds this pressure for 10 seconds. If the pressure should fall during this 10-second interval, it means that there is a leaking point in the system; In such a case, inspect the entire system and replace the leaking component or part.
2. Test the radiator cap for relieving pressure by using the radiator tester in the following manner: Fit the cap to the tester, as shown, and build up pressure slowly by operating the tester. Make sure that the pressure build-up stops at  $0.9 \pm 0.1 \text{ kg/cm}^2$  and that, with the tester held at a standstill, the cap is capable of that pressure for at least 10 seconds. Replace the cap if it is found not to satisfy either of these two requirements.

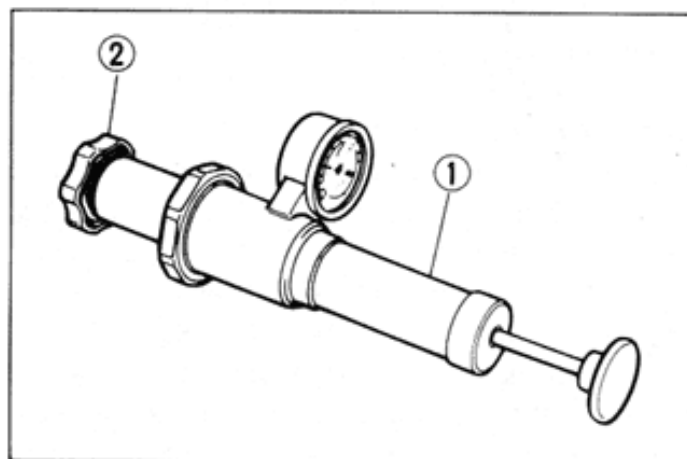

① Radiator cap tester ② Radiator cap

Radiator cap valve release pressure	$90 \pm 15 \text{ kPa}$ $(0.90 \pm 0.15 \text{ kg/cm}^2)$ $(12.8 \pm 2.1 \text{ psi})$
-------------------------------------	--

3. Road dirt or trash stuck to the fins must be removed. Use of compressed air is recommended for this cleaning. Fins bent down or dented can be repaired by straightening them with the blade of a small screwdriver.
4. Any water hose found in cracked condition or flattened must be replaced.

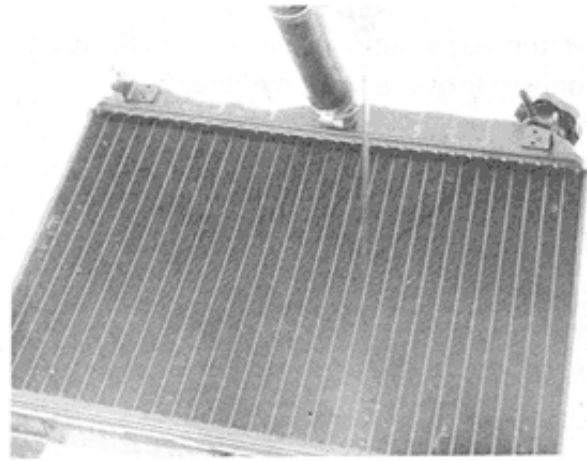

## RADIATOR HOSE

Inspect for leakage from the radiator hose connecting (joint) section and from the radiator hose itself and fork kinks in the radiator hose.

If any leakage from the radiator hose are detected, the radiator hose should be replaced.

Any leakages from the connecting (joint) section should be corrected by proper tightening.

## INSTALLATION

The radiator is to be installed in the reverse order of the removal procedure. After installing the radiator, be sure to add coolant: refer to page 2-10 for refilling information.

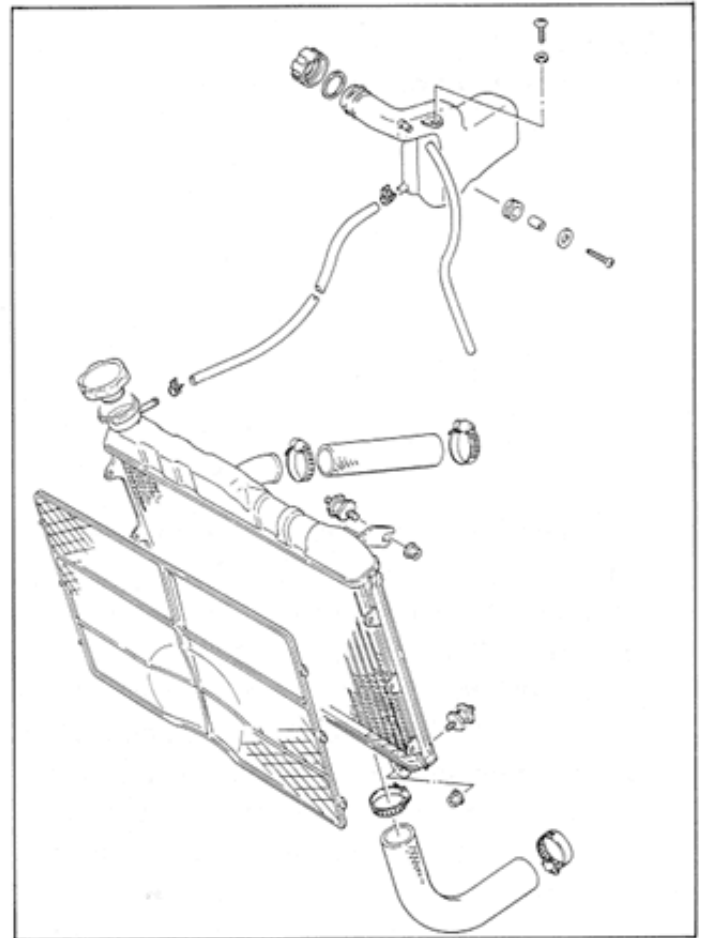

## THERMOSTAT

### REMOVAL

- Drain the coolant.
- Remove the water hoses and radiator.
- Remove the thermostat cover from the cylinder head.

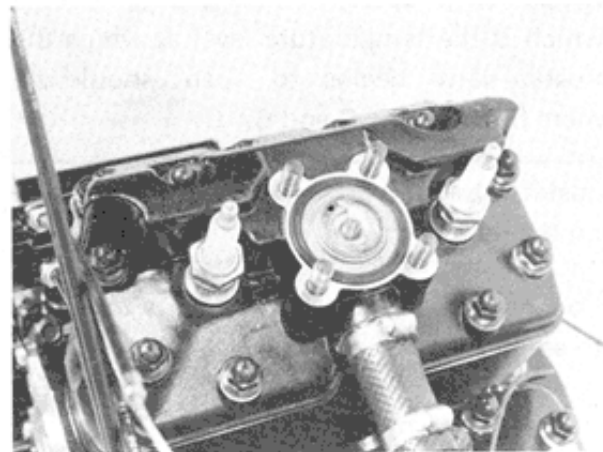

- Remove the water temp. gauge ① from the water hose connector of the front cylinder head.

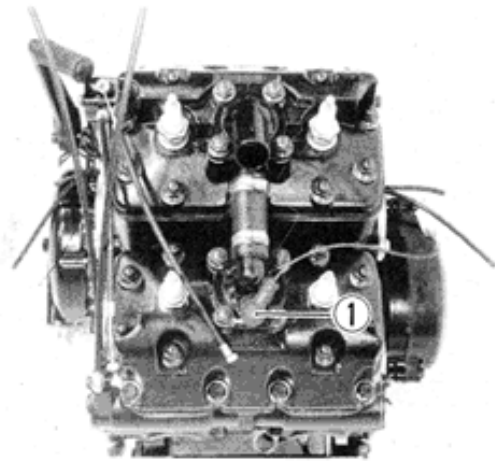

### INSPECTION

Inspect the thermostat pellet for signs of cracking.

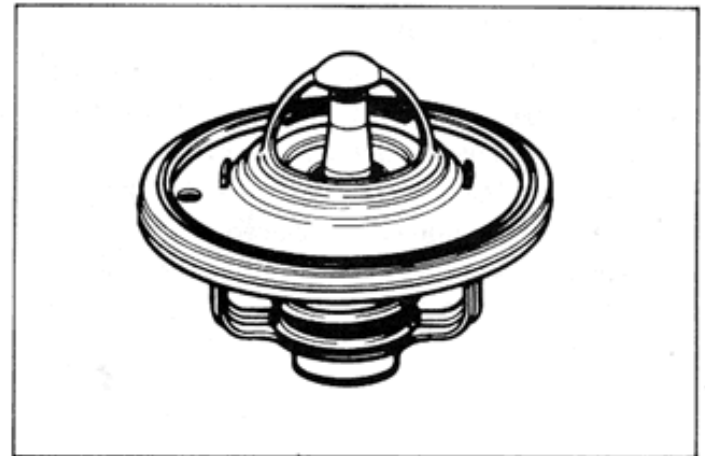

Test the thermostat at the bench for control action, in the following manner.

- Pass a fine thread between valve and seat, as shown in the illustration.
- Immerse the thermostat in the water contained in the pan, as shown in the illustration. Note that the immersed thermostat is in suspension. Heat the water by placing the pan on a stove and observe the rising temperature on the thermometer.
- Read the thermometer just when the thermostat drops to the bottom of the pan. This reading, which is the temperature level at which the thermostat valve begins to open, should be anywhere between 63°C and 67°C.

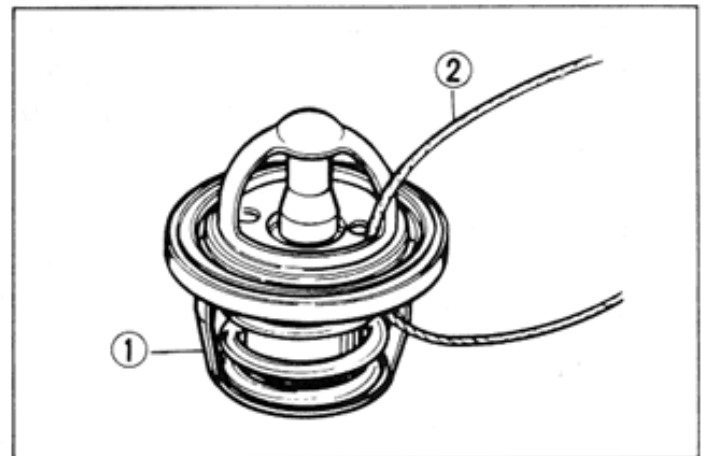

① Thermostat ② Fine thread

Thermostat valve opening temperature	$65^{\circ} \pm 2^{\circ} \text{C}$
--------------------------------------	-------------------------------------

- Keep on heating the water to raise its temperature to and beyond 80°C.

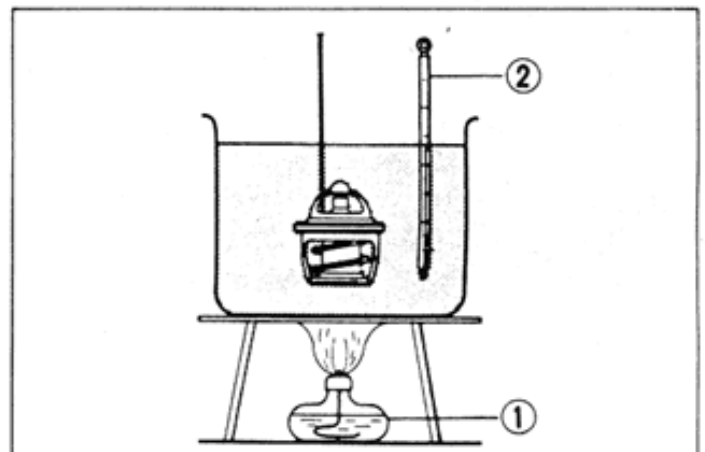

① Stove ② Thermometer

- Just when the water reaches 80°C, the thermostat valve should have lifted by at least 8.0 mm.

Thermostat valve lift	Over 8.0 mm at 80°C
-----------------------	---------------------

- A thermostat failing to satisfy either of the two requirements (start-to-open temperature and valve lift) must be replaced.

Tighten the thermostat cover bolts to the specification.

Tightening torque	20 – 24 N·m (2.0 – 2.4 kg·m)
-------------------	---------------------------------

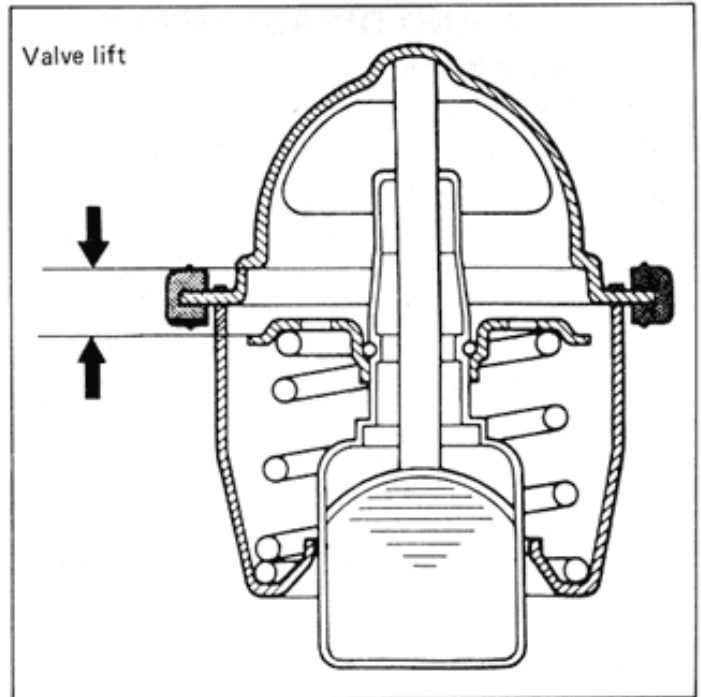

## WATER PUMP

The diagram shows an exploded view of a water pump assembly. The main components are labeled with circled numbers 1 through 8. A legend on the right side of the diagram identifies these parts:

- ① Water pump driven gear
- ② Water pump drive bevel gear
- ③ Housing
- ④ Water pump shaft
- ⑤ Bearing
- ⑥ Oil seal
- ⑦ Mechanical seal
- ⑧ Impeller

On the left side of the diagram, there are three specific assembly points labeled A, B, and C, each with a corresponding bolt or nut. A separate table provides the tightening torque for these points.

Item	N·m	kg·m
Ⓐ	7 – 11	0.7 – 1.1
Ⓑ	4 – 7	0.4 – 0.7
Ⓒ	15 – 20	1.5 – 2.0

## REMOVAL AND DISASSEMBLY

- Remove the fairings.
- Drain the coolant and remove the radiator.
- Remove the exhaust pipes and mufflers for Nos. 1 and 2 cylinders.
- Drain the transmission oil.
- Remove the water pump cover and remove the water pump assembly.
- Remove the impeller while holding the water pump driven gear.

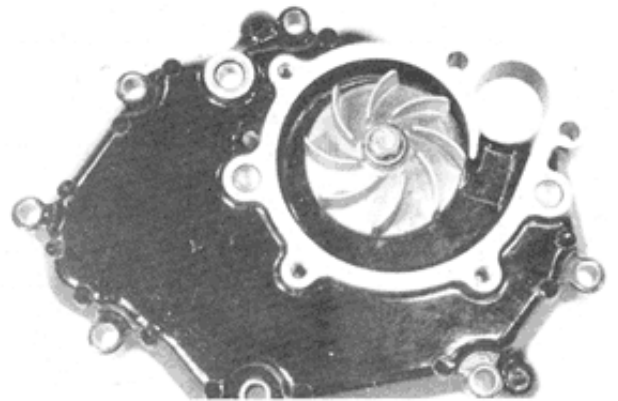
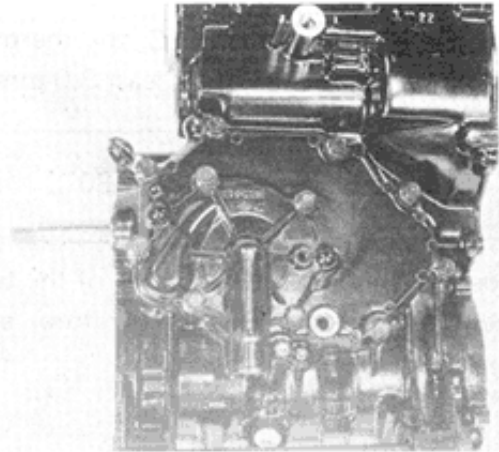

- Remove the water pump driven gear ① using the snapping pliers.

09900-06107	Snapping pliers
-------------	-----------------

- Remove the water pump drive bevel gear ② from the shaft.

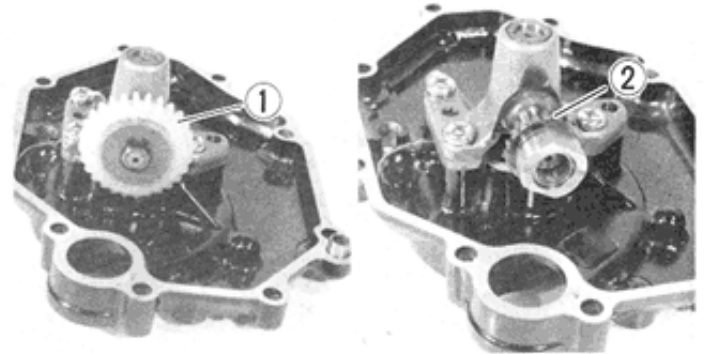

- Using impact driver, remove the housing ③, bearing and water pump shaft ④.

09900-09003	Impact driver set
-------------	-------------------

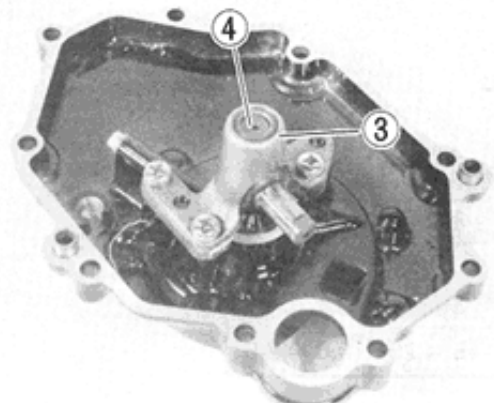

- Remove the oil seal ① using a screw driver.

**NOTE:**

The removed oil seal should be replaced with a new one.

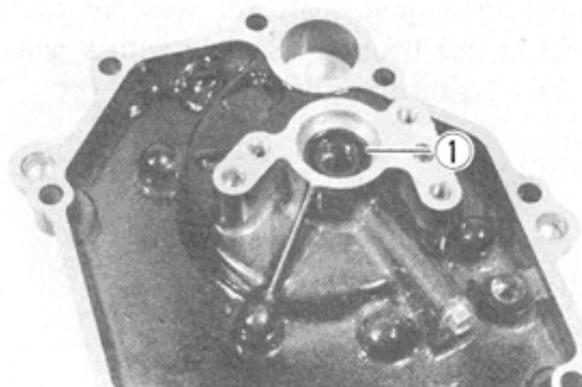

- Remove the water pump mechanical seal using a suitable drift.

**NOTE:**

The removed mechanical seal should be replaced with a new one.

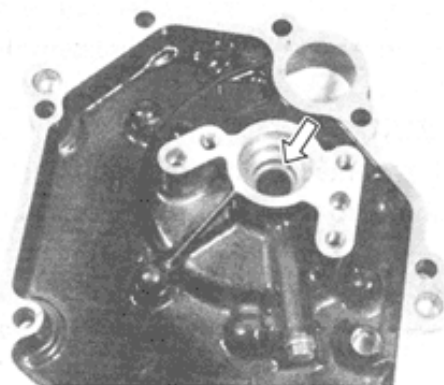
**INSPECTION**

Visually inspect the mechanical seal, seal washer and oil seal.

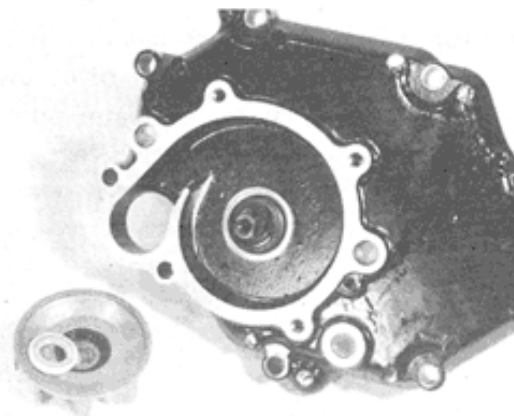

Turn the water pump driven gear by hand and check to see that water pump shaft turns smoothly. Replace the bearing or bevel gears if there is something unusual.

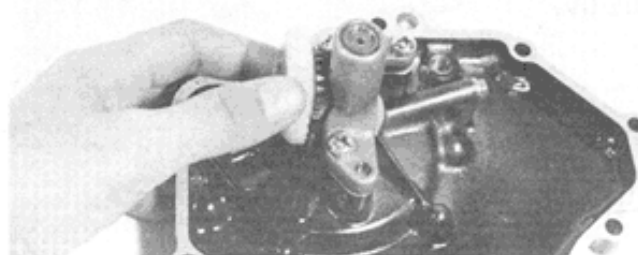

- Inspect the water pump shaft bushing and water pump drive gear shaft for wear or scuffing. Replace the housing assembly with a new one if there is something unusual.

### REASSEMBLY

Reassemble and remount the water pump related parts in the reverse order of disassembly and removal.

- Apply SUZUKI Bond No. 1207B to the sealing surface of the mechanical seal and install the mechanical seal to the water pump case.

99000-31140	SUZUKI Bond No. 1207B
-------------	-----------------------

- Apply SUZUKI Super grease "A" or transmission oil lightly to the lip of a new oil seal and install a oil seal to the water pump case in the proper direction.

- Install the bearing and water pump shaft to the water pump case.
- After installing the water pump shaft, check to see that the water pump shaft turns lightly and quietly.

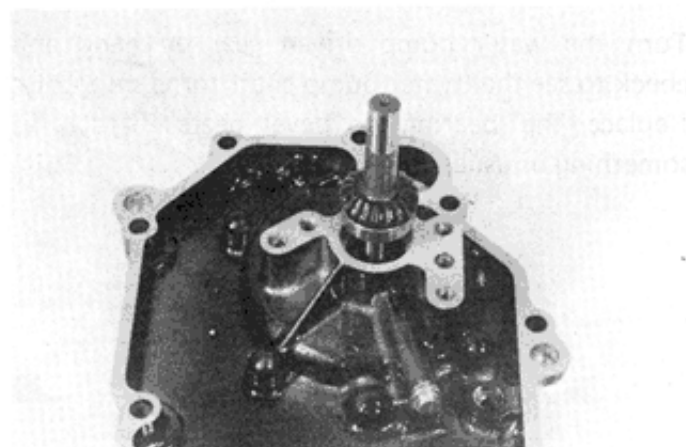
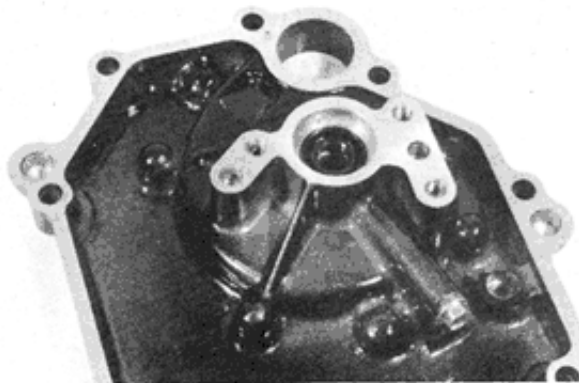
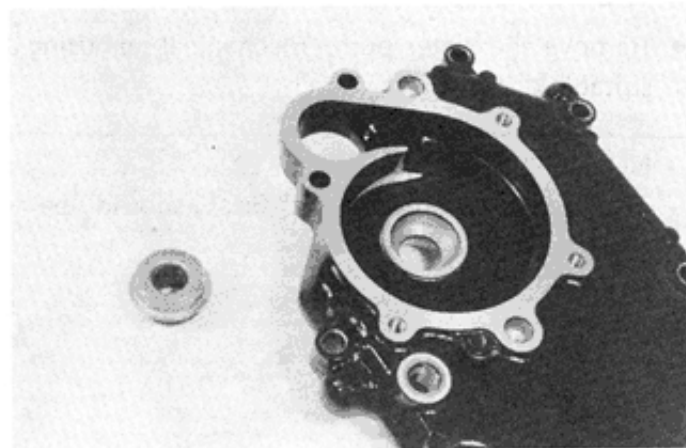

- Apply transmission oil to the water pump shaft and housing bushing lightly.
- Install a positioning pin and install the housing through the water pump drive shaft.
- Apply SUZUKI Thread Lock 1333 to the housing screws.

99000-32020

Thread lock "1333"

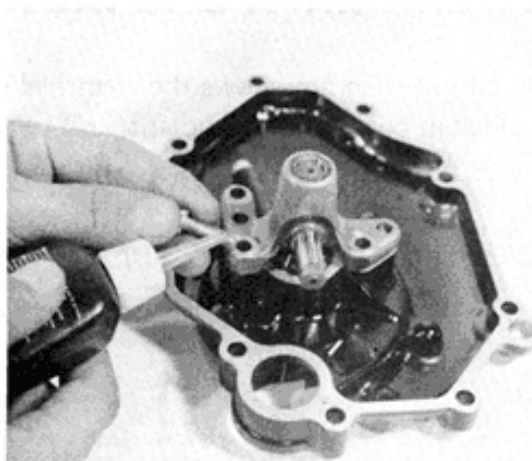

- Turn the water pump driven gear by hand and make sure that water pump shaft turns smoothly, If the water pump shaft does not turn smoothly, lightly tap the water pump shaft from the impeller side.

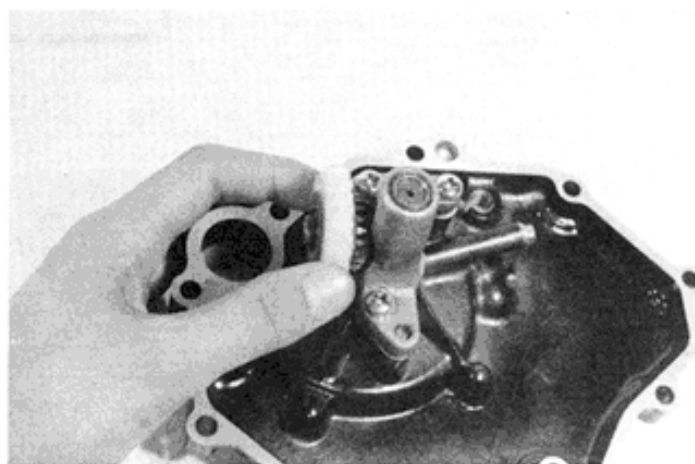

- Use a new gasket ① for impeller center bolt. When installing the gasket, face the iron side to the spring washer and bolt head.

Tightening torque

7 – 11 N·m  
(0.7 – 1.1 kg-m)

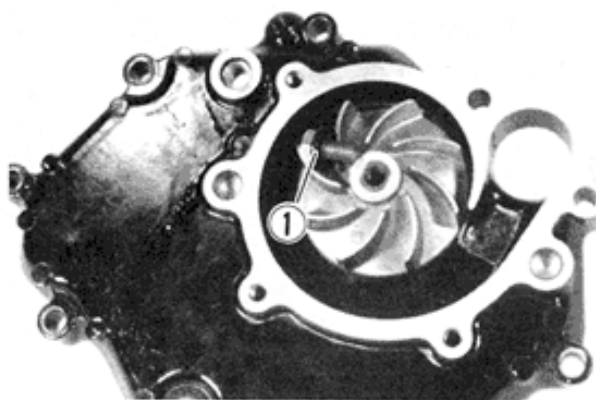

- Install a new O-ring and tighten the water pump cover bolt to the specified torque.

Tightening torque

8 – 12 N·m  
(0.8 – 1.2 kg-m)

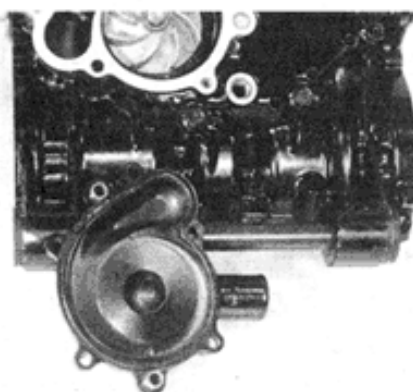

## WATER TEMPERATURE METER AND TEMPERATURE GAUGE

The following circuit diagram shows the electrical wiring for the thermometer. The major components are temperature gauge in contact with coolant; and temperature indicator (water temperature meter).

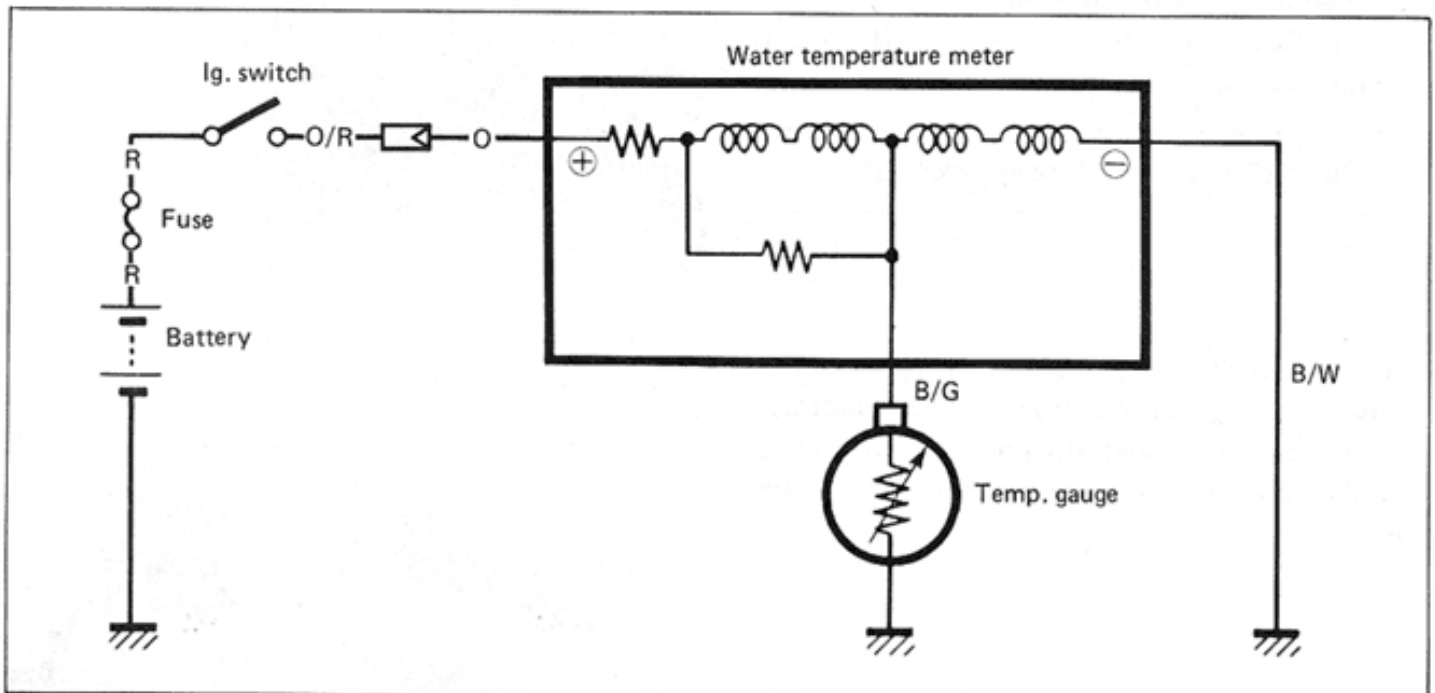

### INSPECTION

Remove the temperature gauge from the front cylinder head cap.

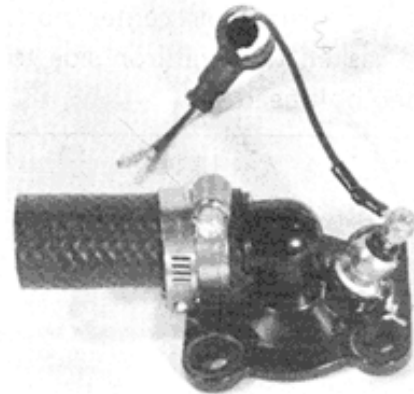

Test the temperature gauge sensor at the bench to see if its ohmic value changes, as specified, with temperature. The test is to be run as follows: Connect the temperature gauge to the ohmmeter and place it in the oil contained in a pan, which is placed on a stove; heat the oil to raise its temperature slowly, reading the thermometer placed in the pan and also the ohmmeter. A temperature gauge whose ohmic value does not change in the proportion indicated in the following table must be replaced.

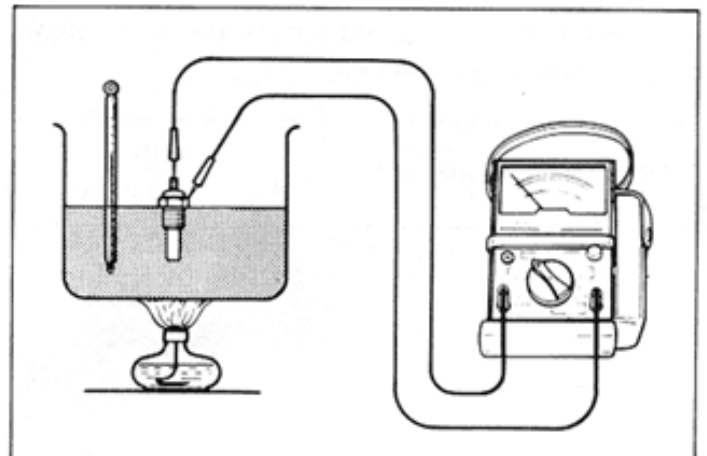

### Temperature gauge specification

Oil temp. °C	Standard resistance ( $\Omega$ )
50	Approx. $226 \pm 30\%$
115	$26.4 \pm 10\%$

If the resistance noted to show infinity or too much difference in resistance value, temperature gauge must be replaced.

For inspecting the water temperature meter, refer to page 6-12.

### REASSEMBLY

Apply SUZUKI Bond No. 1207B to the thread portion of the temperature gauge and install it to the water hose connector.

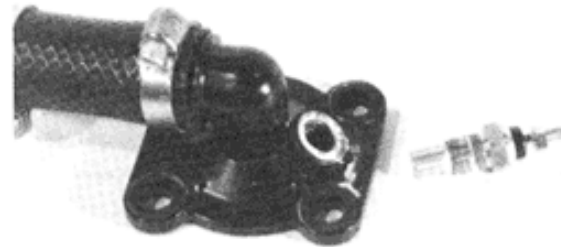

#### CAUTION:

Take special care when handling the temperature gauge. It may cause damage if it gets a sharp impact.

99000-31140	SUZUKI Bond No. 1207B
Tightening torque	12 – 18 N·m (1.2 – 1.8 kg·m)

# FUEL AND LUBRICATION SYSTEM

## CONTENTS

<i>FUEL TANK AND FUEL COCK</i> .....	5- 1
<i>CARBURETOR</i> .....	5- 2
<i>CONSTRUCTION</i> .....	5- 2
<i>SPECIFICATIONS</i> .....	5- 3
<i>I.D. NO. LOCATION</i> .....	5- 3
<i>REMOVAL AND DISASSEMBLY</i> .....	5- 4
<i>NEEDLE VALVE INSPECTION</i> .....	5- 6
<i>FLOAT HEIGHT ADJUSTMENT</i> .....	5- 7
<i>REASSEMBLY AND REMOUNTING</i> .....	5- 7
<i>FUEL LEVEL INSPECTION</i> .....	5- 8
<i>BALANCING CARBURETORS</i> .....	5- 9
<i>OIL PUMP</i> .....	5-10
<i>BLEEDING AIR FROM THE OIL PUMP CIRCUIT</i> .....	5-10
<i>CHECKING OIL PUMP</i> .....	5-10

## FUEL TANK AND FUEL COCK

The fuel tank is provided with a tank cap and fuel filter. An air vent is provided in the tank cap to supply gasoline smoothly to the carburetor. The fuel cock has the structure as shown in the illustration. A valve is provided at the bottom of the fuel tank which is linked to the fuel cock lever and can switch over to "OFF", "ON" and "RES". With the valve ON (normal), the main passage opens. With the valve OFF, both holes close.

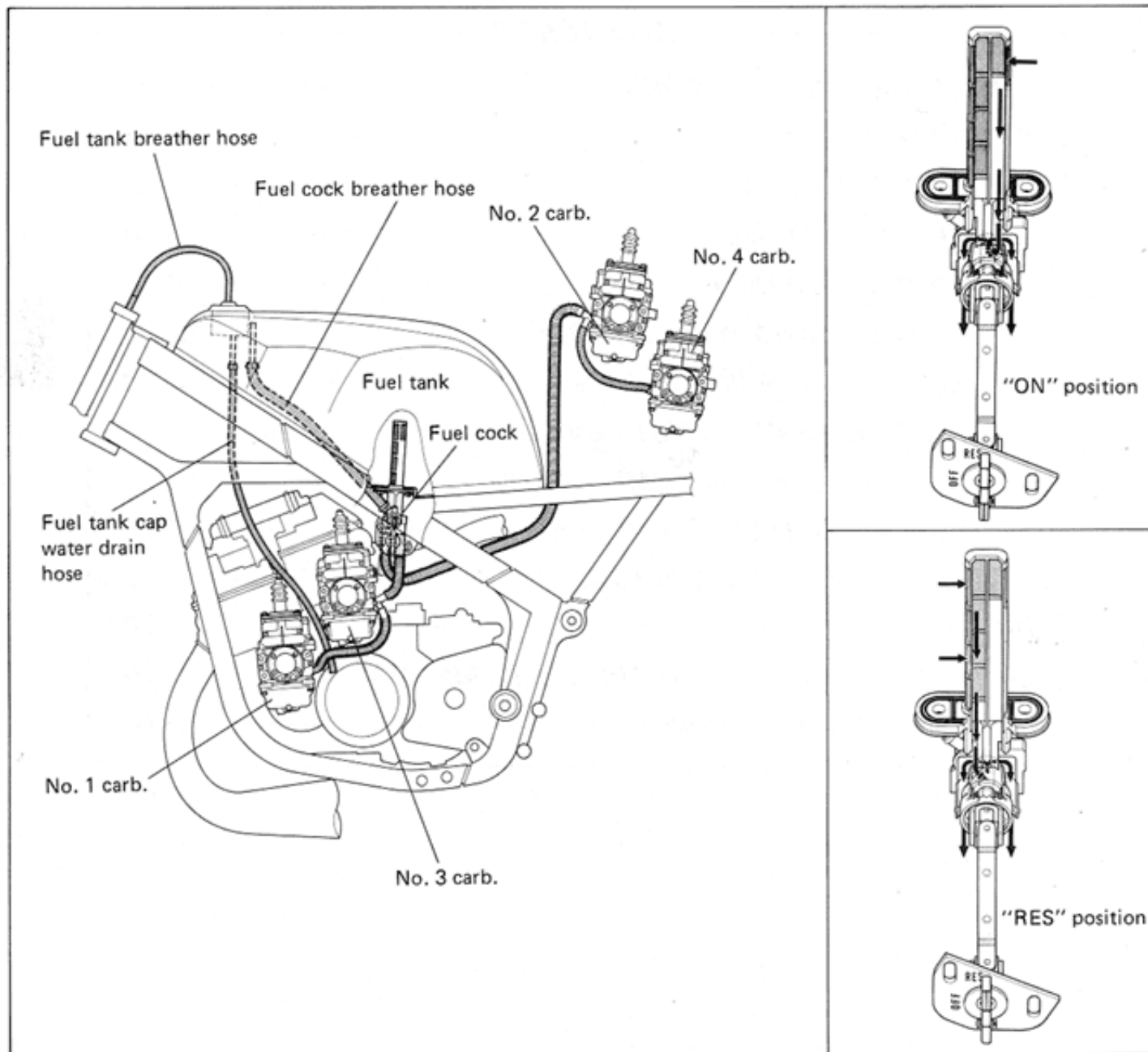

### CLEAN

The fuel cock filter will collect impurities, and therefore must be periodically checked and cleaned. The fuel tank should be cleaned at the same time the fuel cock filter is being cleaned.

### INSPECTION

If the fuel leaks from around the fuel cock or from the filter connection part of cock, gasket may be damaged. Visually inspect these parts, and replace them if necessary. Examine the air vent in the fuel cock to see if it is obstructed. Use compressed air to clean an obstructed vent.

# CARBURETOR CONSTRUCTION

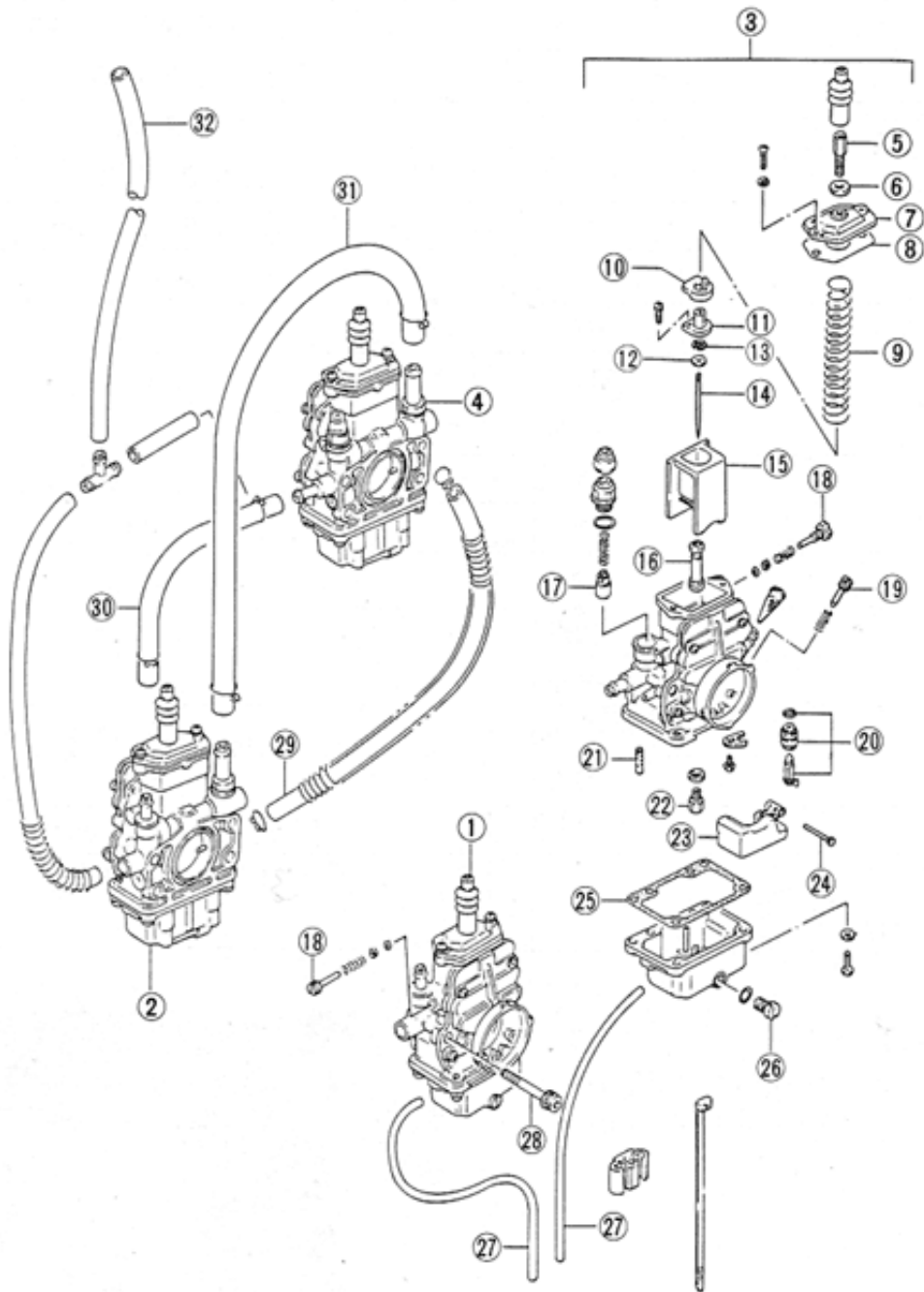

- |                                |                       |                            |
|--------------------------------|-----------------------|----------------------------|
| ① Carburetor assembly No. 1    | ⑫ Washer              | ⑳ Float                    |
| ② Carburetor assembly No. 2    | ⑬ E-ring              | ㉑ Float pin                |
| ③ Carburetor assembly No. 3    | ⑭ Jet needle          | ㉒ Gasket                   |
| ④ Carburetor assembly No. 4    | ⑮ Throttle valve      | ㉓ Drain screw              |
| ⑤ Throttle cable adjuster      | ⑯ Needle jet          | ㉔ Overflow pipe            |
| ⑥ Lock nut                     | ⑰ Starter plunger     | ㉕ Carburetor mounting bolt |
| ⑦ Carburetor top cap           | ⑱ Throttle stop screw | ㉖ Fuel hose                |
| ⑧ Gasket                       | ⑲ Pilot air screw     | ㉗ Starter hose             |
| ⑨ Throttle valve return spring | ㉑ Needle valve        | ㉘ S.I.P.C. hose            |
| ⑩ Cable holder                 | ㉒ Pilot jet           | ㉙ Breather hose            |
| ⑪ Jet needle stopper plate     | ㉓ Main jet            |                            |

## SPECIFICATIONS

ITEM		SPECIFICATION
Type		MIKUNI VM28SH
I.D. No.		21A00
Bore		28 mm
Idle r/min		1,500 ± 150 r/min
Fuel level		5.5 ± 0.5 mm
Float height		17.0 ± 1.0 mm
Main jet	(M.J.)	# 120
Main air jet	(M.A.J)	0.5 mm
Jet needle	(J.N.)	5CM1-2nd
Needle jet	(N.J.)	P - 5
Cut-away	(C.A.)	2.0
Pilot jet	(P.J.)	# 25
By-pass	(B.P.)	1.2 mm
Pilot outlet	(P.O.)	0.6 mm
Valve seat	(V.S.)	2.5 mm
Starter jet	(G.S.)	# 50
Pilot air screw	(P.A.S.)	PRE-SET (1-5/8 turns back)
Choke cable play		0.5 - 1.0 mm
Throttle cable play		0.5 - 1.0 mm

## I.D. NO. LOCATION

Each carburetor has I.D. Number ① stamped on the carburetor body according to its specifications.

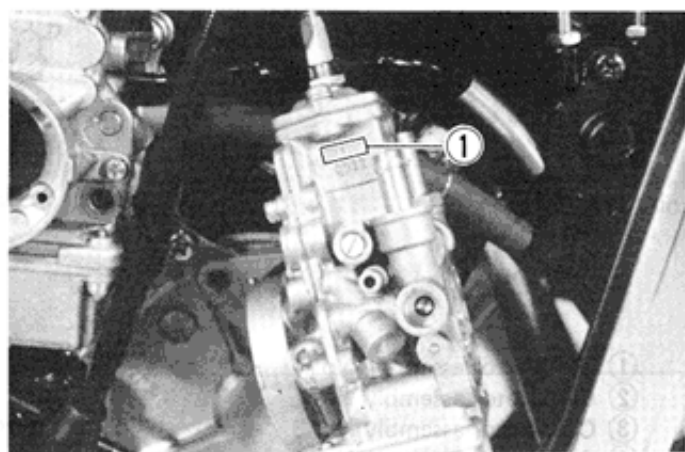

**REMOVAL AND DISASSEMBLY**

- Remove the middle fairings. (Refer to page 7-2.)
- Turn the fuel cock to "OFF" position.
- Remove the intake pipe by loosening clamp screws.

**NOTE:**

Identify the four throttle valves removed as No. 1 through No. 4, in order to make sure each will be restored to the carburetor from which it was taken out.

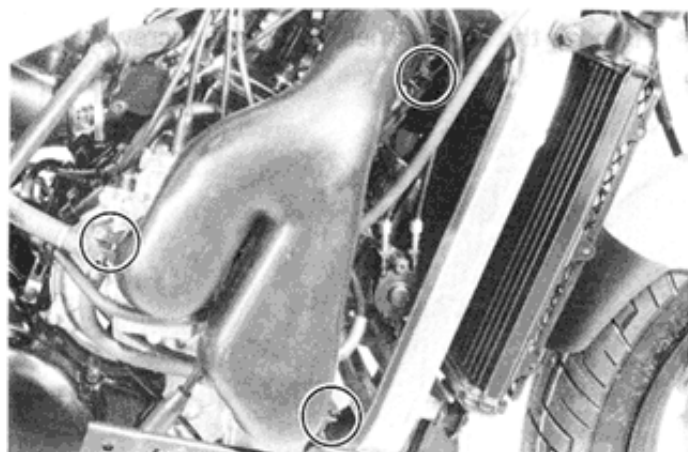

- Disconnect the fuel hose ①.
- Disconnect the throttle cables ② and choke cable ③.
- Take out the two carburetors by loosening carburetor mounting bolts.

**NOTE:**

When disconnecting the throttle cables and choke cable, it is necessary to remove the carburetor top caps and starter plunger.

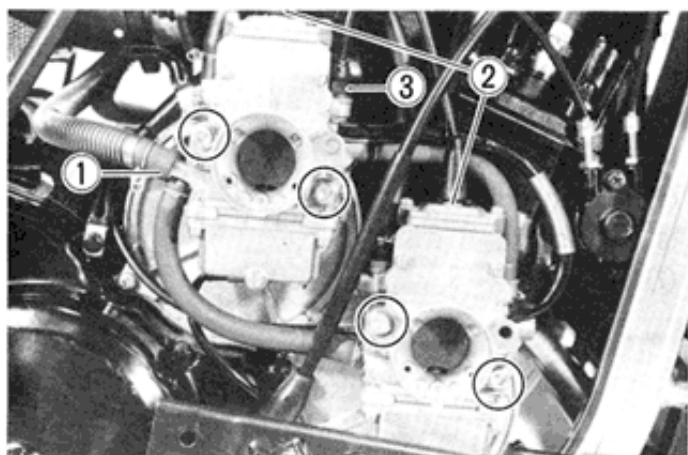

- Separate the two carburetors by disconnecting fuel hose ①, starter hose ②, S.I.P.C. hose ③ and breather hose ④.

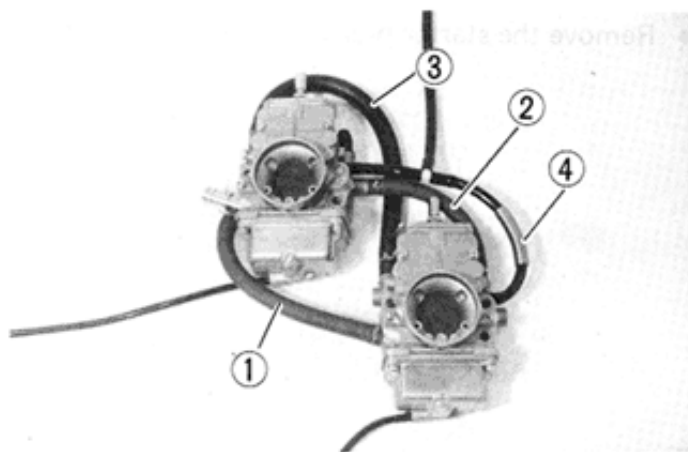

- Remove the carburetor top cap and take out the throttle valve ① and return spring ②.

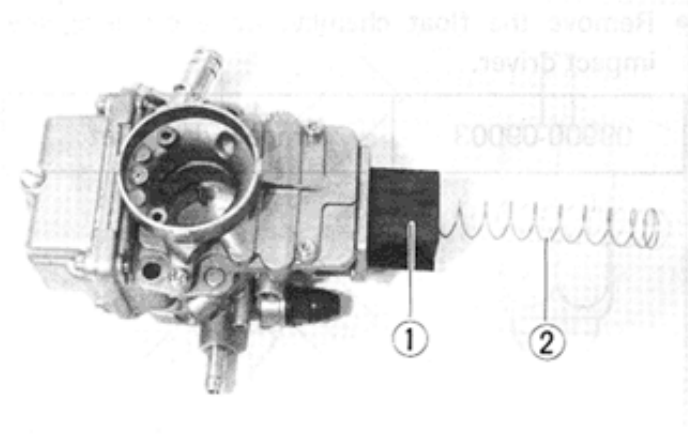

- Remove the two jet needle stopper screws.

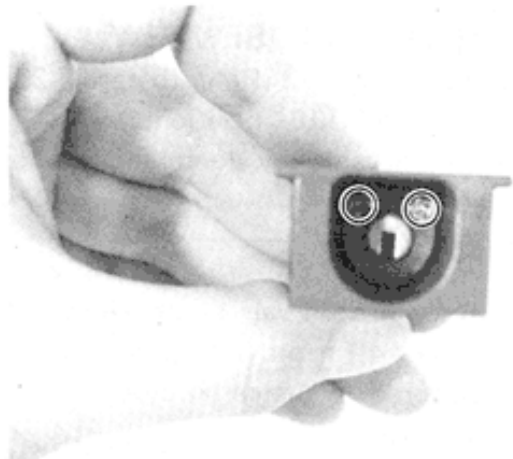

- ① : Throttle valve
- ② : Stopper plate
- ③ : Screw
- ④ : Cable holder
- ⑤ : Jet needle
- ⑥ : Washer
- ⑦ : E-ring

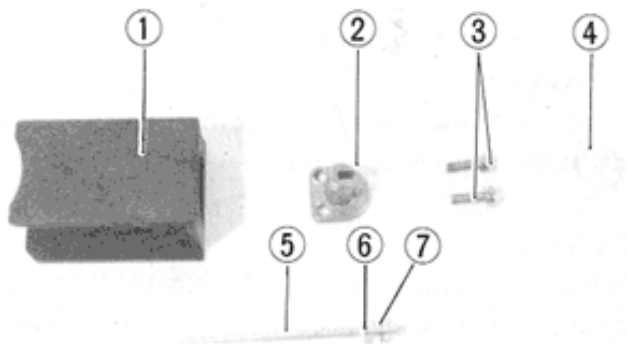

- Remove the starter plunger ① and spring ②.

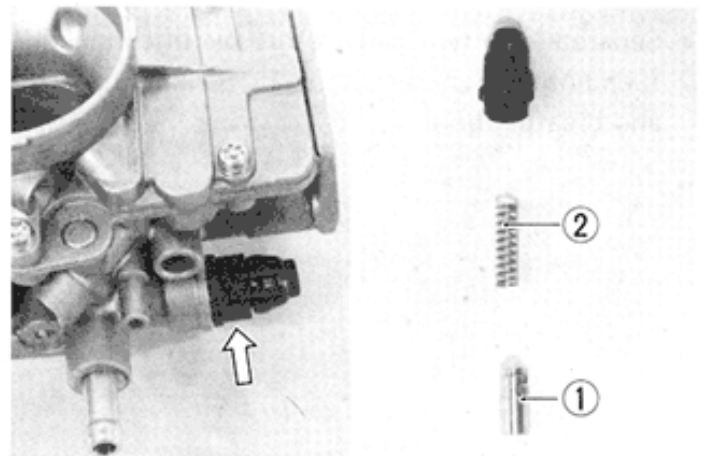

- Remove the float chamber body by using the impact driver.

09900-09003	Impact driver set
-------------	-------------------

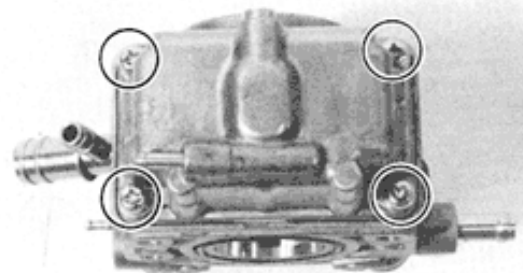

- Pull out the float pin ① and remove the float.

**CAUTION:**

When removing the float pin, be careful not to damage the carburetor body.

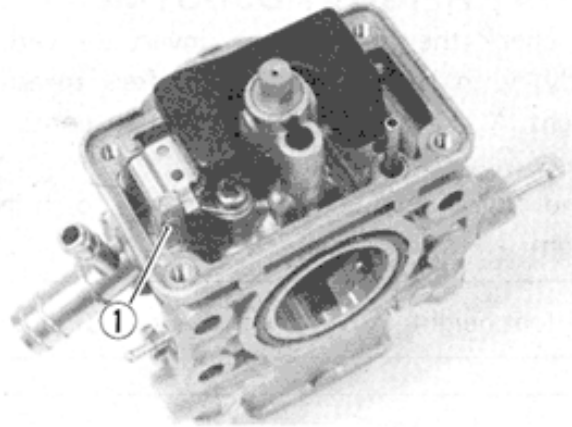

- Remove the main jet ① and take out the needle jet from the bore side.
- Remove the pilot jet ②.
- Remove the needle valve retainer screw ③ and take out the needle valve ④.
- Check following items for any damage or clogging.
  - \* Pilot jet
  - \* Main jet
  - \* Main air jet
  - \* Needle jet air bleeding holes
  - \* Float
  - \* Needle valve O-ring
  - \* CCI oil outlet nozzle hole
  - \* Gasket and O-ring
  - \* Pilot outlet and by-pass hole
  - \* Fuel pipe O-rings

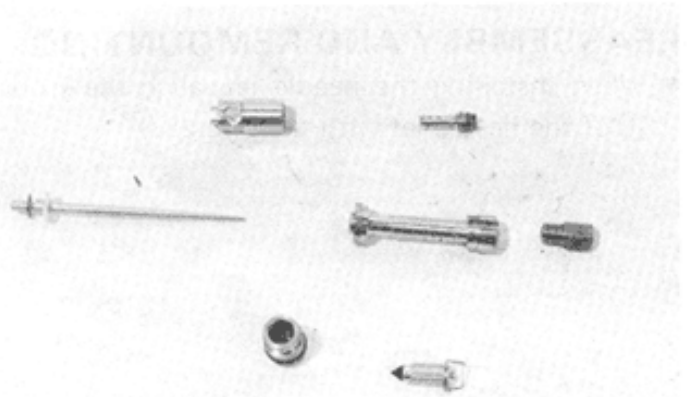
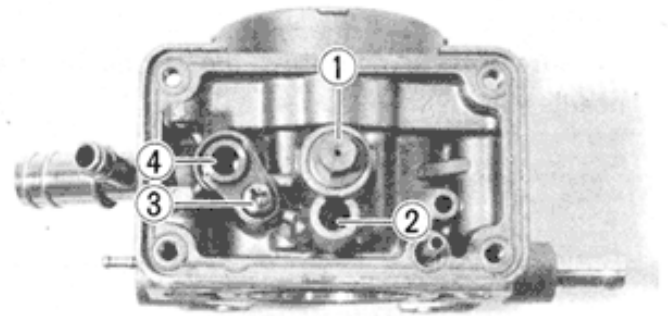

**NEEDLE VALVE INSPECTION**

If foreign matter is caught between the valve seat and the needle, the gasoline will continue flowing and cause it to overflow. If the seat and needle are worn beyond the permissible limits, similar trouble will occur. Conversely, if the needle sticks, the gasoline will not flow into the float chamber. Clean the float chamber and float parts with gasoline. If the needle is worn as shown in the illustration, replace it together with a valve seat. Clean the fuel passage of the mixing chamber with compressed air.

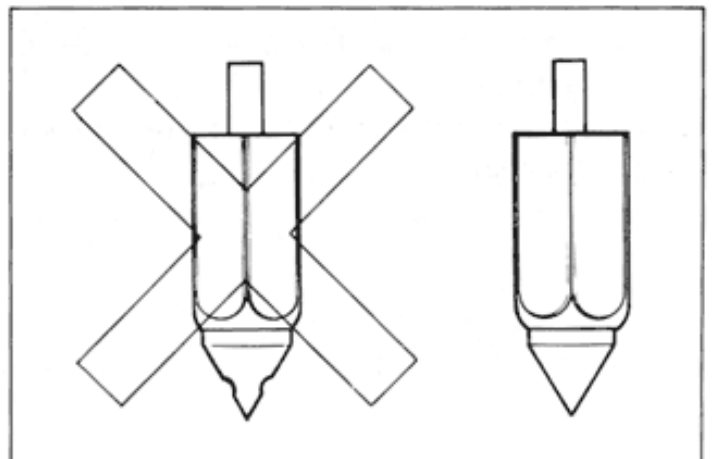

### FLOAT HEIGHT ADJUSTMENT

To check the float height, invert the carburetor body, with the float arm kept free, measure the height **A** while float arm is just in contact with needle valve by using calipers.

Bend the tongue **1** as necessary to bring the height **A** to this value.

Float height <b>A</b>	17.0 ± 1.0 mm
-----------------------	---------------

09900-20102	Vernier calipers
-------------	------------------

**NOTE:**

Be sure not to compress the spring in the needle valve.

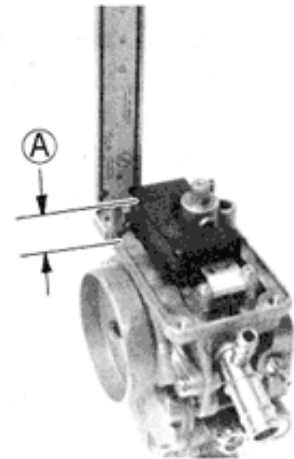

### REASSEMBLY AND REMOUNTING

- When installing the needle jet, align the groove **1** of the needle jet with the pin **2**.

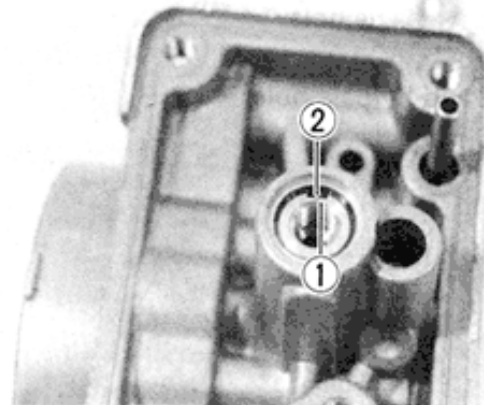

- There are numbers on the cables which indicate the cylinder number. Connect each cable to each carburetor according to the numbers.

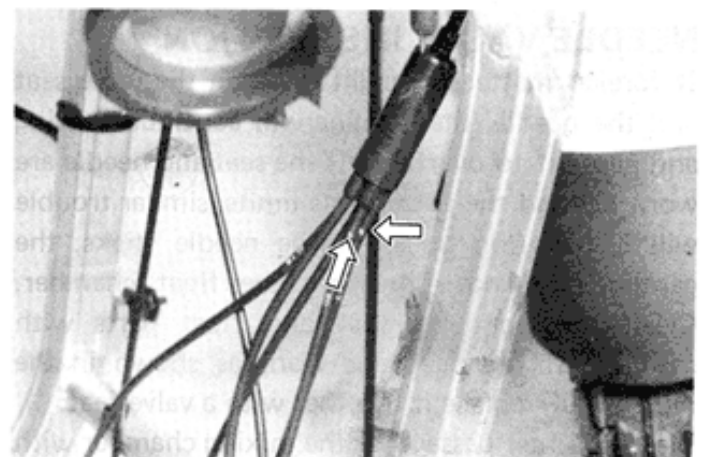

- Tighten the carburetor mounting bolts to the specified torque. (Refer to page 3-9)

Carburetor mounting bolts tightening torque	7 – 9 N·m (0.7 – 0.9 kg·m)
---	-------------------------------

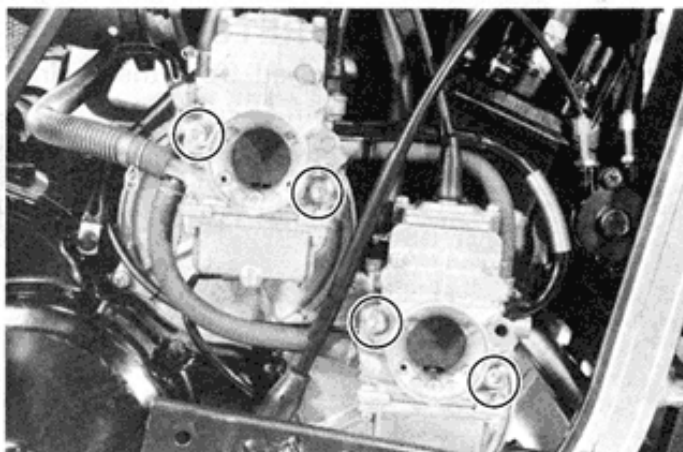

- After all work is completed, the following adjustments are necessary.

- \* Balancing carburetors ..... Page 5-9
- \* Throttle cable play ..... Page 2-7
- \* Engine idle r/min ..... Page 2-6

### FUEL LEVEL INSPECTION

- Remove carburetor drain plug and install the fuel level gauge.

09913-14511	Fuel level gauge
-------------	------------------

- Run the engine at the idling speed (1,350 – 1,650 r/min), and measure the distance **A** holding the motorcycle upright with the middle line of the level gauge aligned with the mating surface of front bowl as shown in photo. **A** should be within the specified range.

Distance <b>A</b>	5.5 ± 0.5 mm
-------------------	--------------

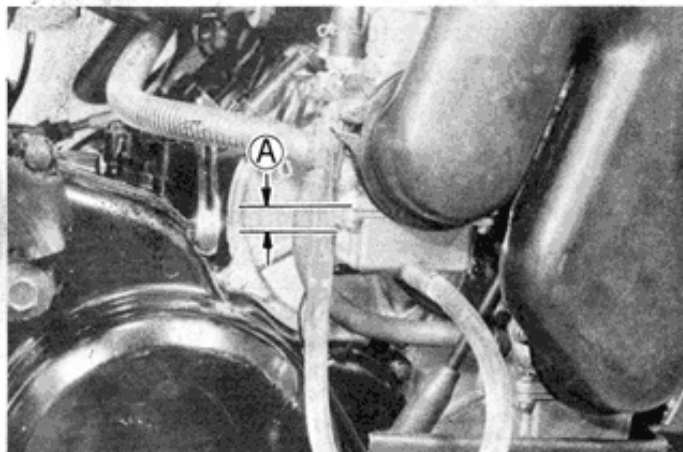

## BALANCING CARBURETORS

If the carburetors are removed from the engine, it is necessary to balance the four carburetors.

- Remove the four carburetors from the engine.
- Loosen the four throttle stop screws.
- Loosen the lock nut ① and turn in the throttle cable adjuster ② to have enough play in the cable for four carburetors.
- Make sure that the four throttle valves close fully.
- Turn the throttle stop screw to have the clearance 0.5 mm between the lower side of the carburetor bore and the lower side of the throttle valve for four carburetors.

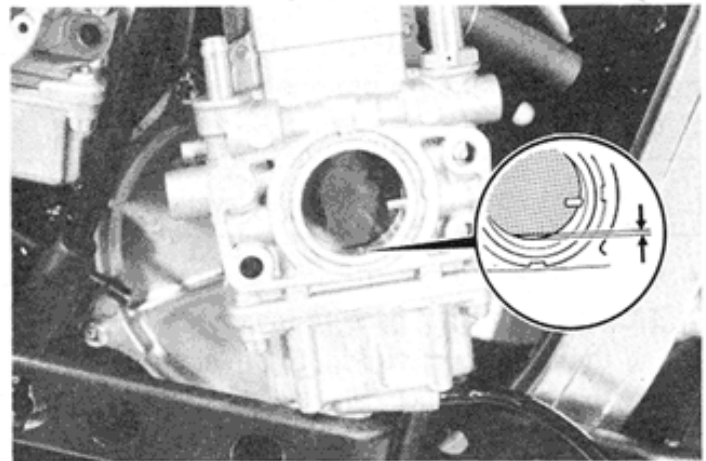
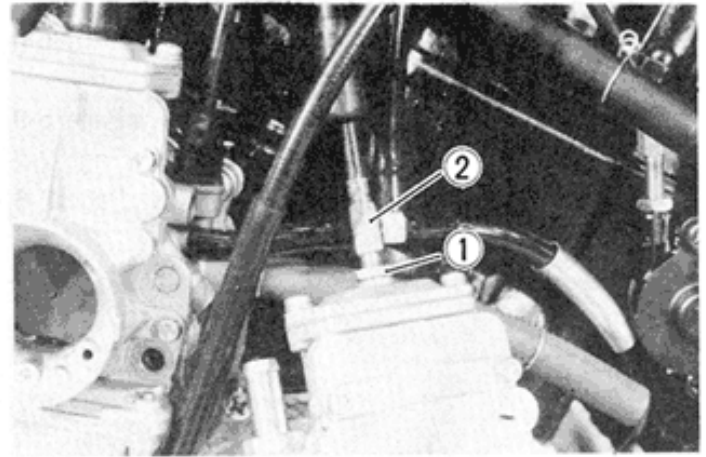
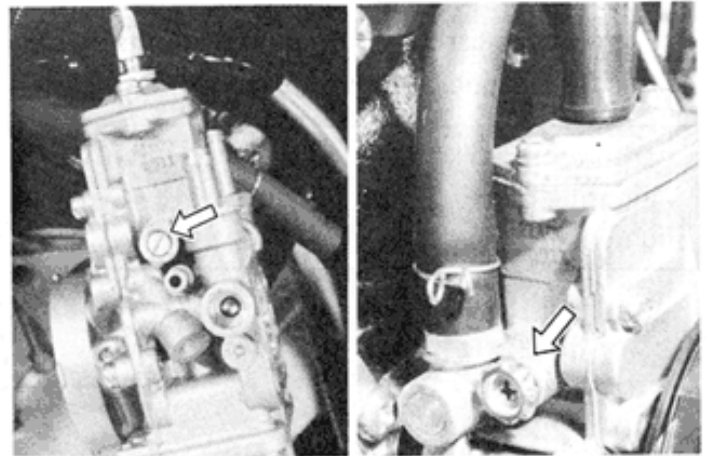

Throttle valve setting position	0.5 mm from the bottom of the main bore
---------------------------------	---

- Install the carburetors to the engine.
- Adjust the throttle cable play. (See page 2-7)
- Confirm that the four dot marks on the throttle valves come to the upper side of the carburetor bore by turning the throttle grip. And at the same time confirm that the line of the oil pump lever aligns the line of the oil pump body when the four dot marks coming to the upper side of the carburetor bore.

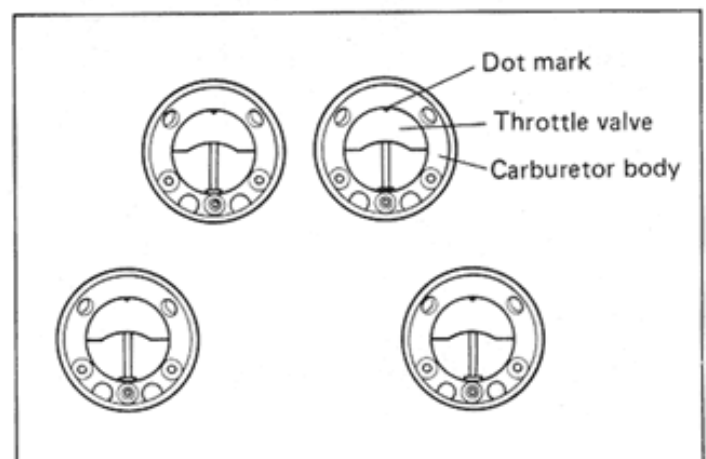

## OIL PUMP

### BLEEDING AIR FROM THE OIL PUMP CIRCUIT

Whenever evidence is noted of some air having leaked into the oil pipe from the oil tank in a machine brought in for servicing, or if the oil pump has to be removed for servicing, be sure to carry out an air bleeding operation with the oil pump in place before returning the machine to the user.

To bleed the air, hold the machine in standstill condition. Loosen the screw ① to let out the air and after making sure that the trapped air has all been bled, tighten the screw good and hard.

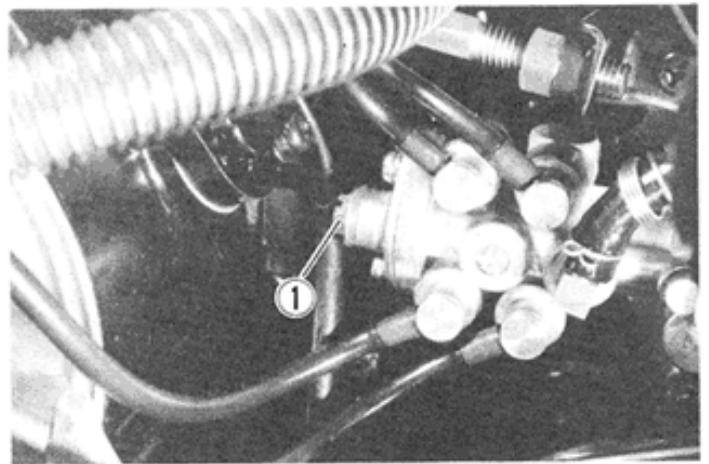

### CHECKING OIL PUMP

Use the special tool, and check the pump for capacity by measuring the amount of oil the pump draws during the specified interval.

- Have the tool filled with SUZUKI CCI or CCI SUPER OIL and connect it to the suction side of the pump.
- Run the engine at 2 000 r/min.
- Holding engine speed at the same 2 000 r/min., move the lever up to the fully open position ② and let the pump draw for 1 minute. For this operation, the reading taken on the device should be 3.2 – 4.0 ml.

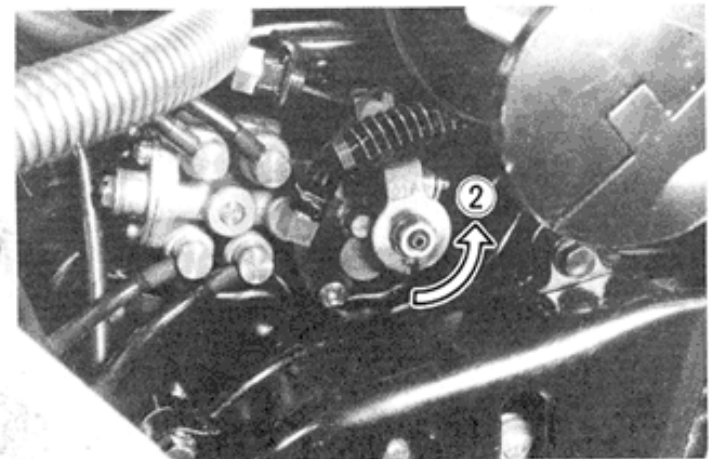
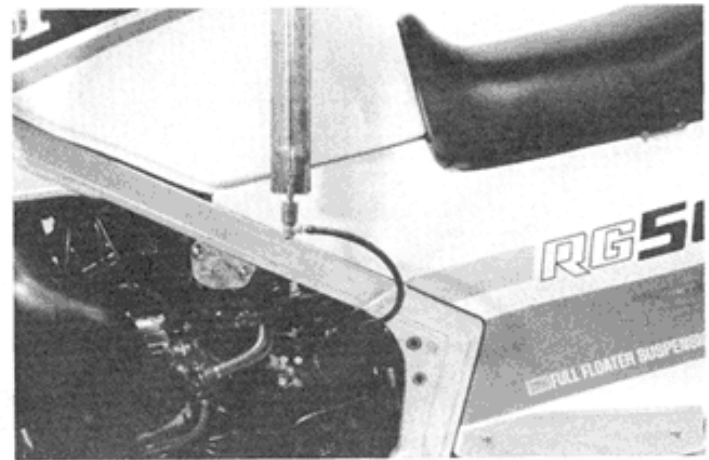

09900-21602

CCI oil gauge

Oil discharge  
amount3.2 – 4.0 ml at 2 000  
r/min for 1 minute

#### NOTE:

Adjust both throttle and oil pump control cables' play after replacing the oil pump.  
(See page 2-7 and 2-8)

# **ELECTRICAL SYSTEM**

## **CONTENTS**

<b>CHARGING SYSTEM</b> .....	<b>6- 1</b>
<b>IGNITION SYSTEM</b> .....	<b>6- 5</b>
<b>AUTOMATIC EXHAUST VALVE CONTROL UNIT AND ACTUATOR</b> .....	<b>6- 8</b>
<b>WATER TEMPERATURE METER</b> .....	<b>6-12</b>
<b>OIL LEVEL GAUGE</b> .....	<b>6-14</b>
<b>LAMPS</b> .....	<b>6-15</b>
<b>SPEEDOMETER</b> .....	<b>6-16</b>
<b>SWITCHES</b> .....	<b>6-18</b>
<b>BATTERY</b> .....	<b>6-19</b>

## CHARGING SYSTEM

### DESCRIPTION

The circuit of the charging system is indicated in figure, which is composed of an AC generator, regulator/rectifier unit and battery.

The AC current generated from AC generator is rectified by rectifier and is turned into DC current, then it charges the battery.

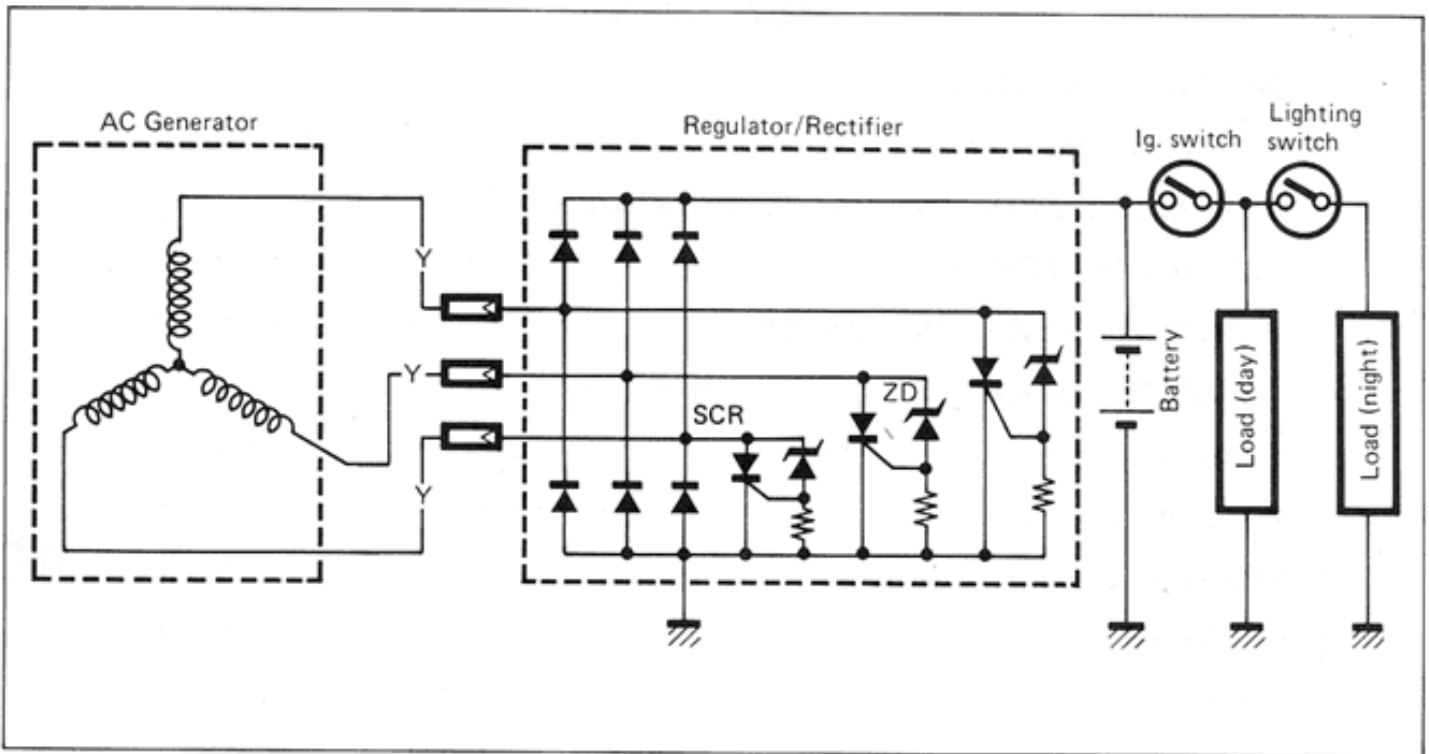

### Function of Regulator

While the engine r/min is low and the generated voltage of AC generator is lower than the adjusted voltage of Regulator, the regulator does not function, incidentally the generated current charges the battery directly.

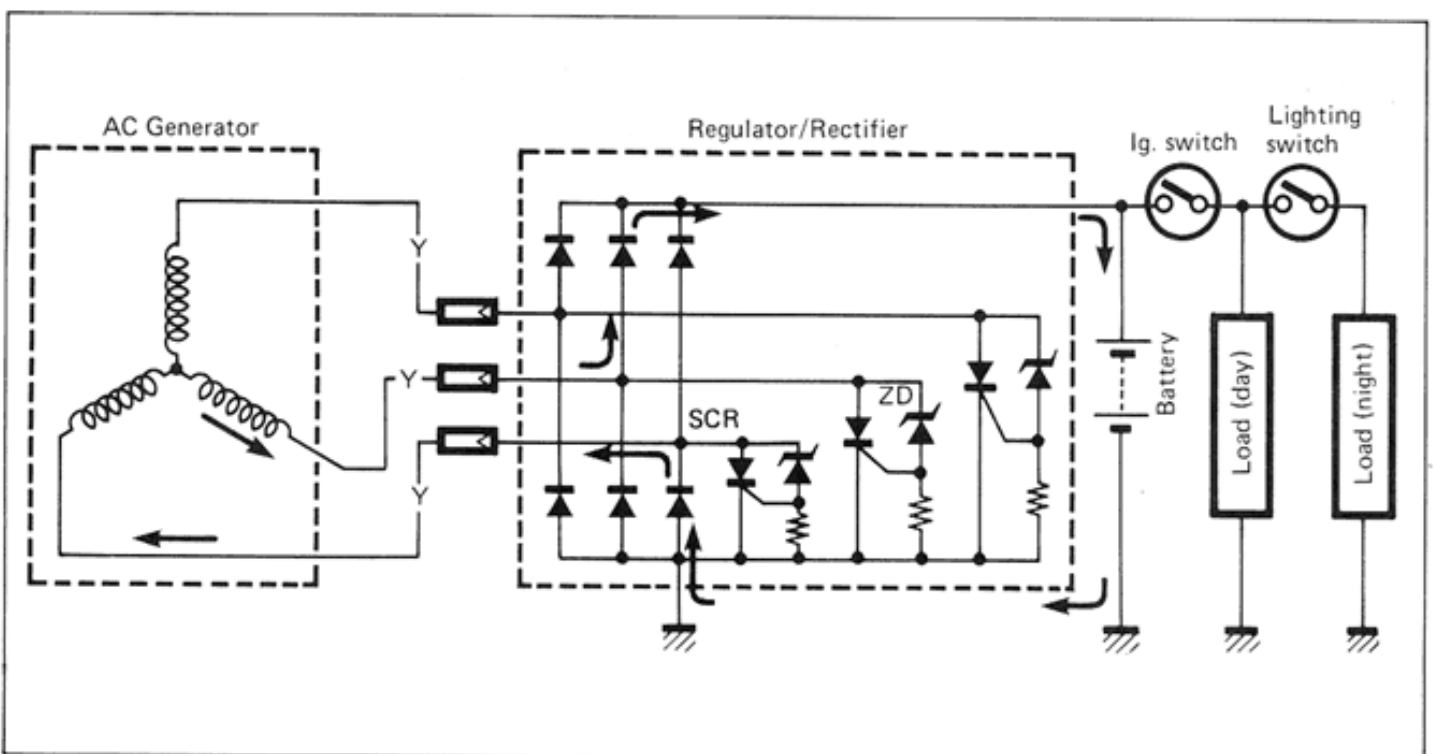

When the engine r/min becomes higher, the generated voltage of AC generator also becomes higher and the voltage between points **A** and **B** of regulator becomes high accordingly, and when it reaches the adjusted voltage of regulator, ZD (Zener diode) becomes "ON" condition and, signal will be sent to the SCR (Thyristor) gate probe and SCR will become "ON" condition.

Then the SCR becomes conductive to the direction from point **C** to point **D**. Namely at the state of this, the current generated from the AC generator gets through SCR without charging the battery and returns to AC generator again. At the end of this state, since the AC current generated from AC generator flows into the point **D**, reverse current tends to flow to SCR, then the circuit of SCR turns to OFF mode and begins to charge the battery again. Thus these repetitions maintain charging voltage to the battery constant and protect it from overcharging.

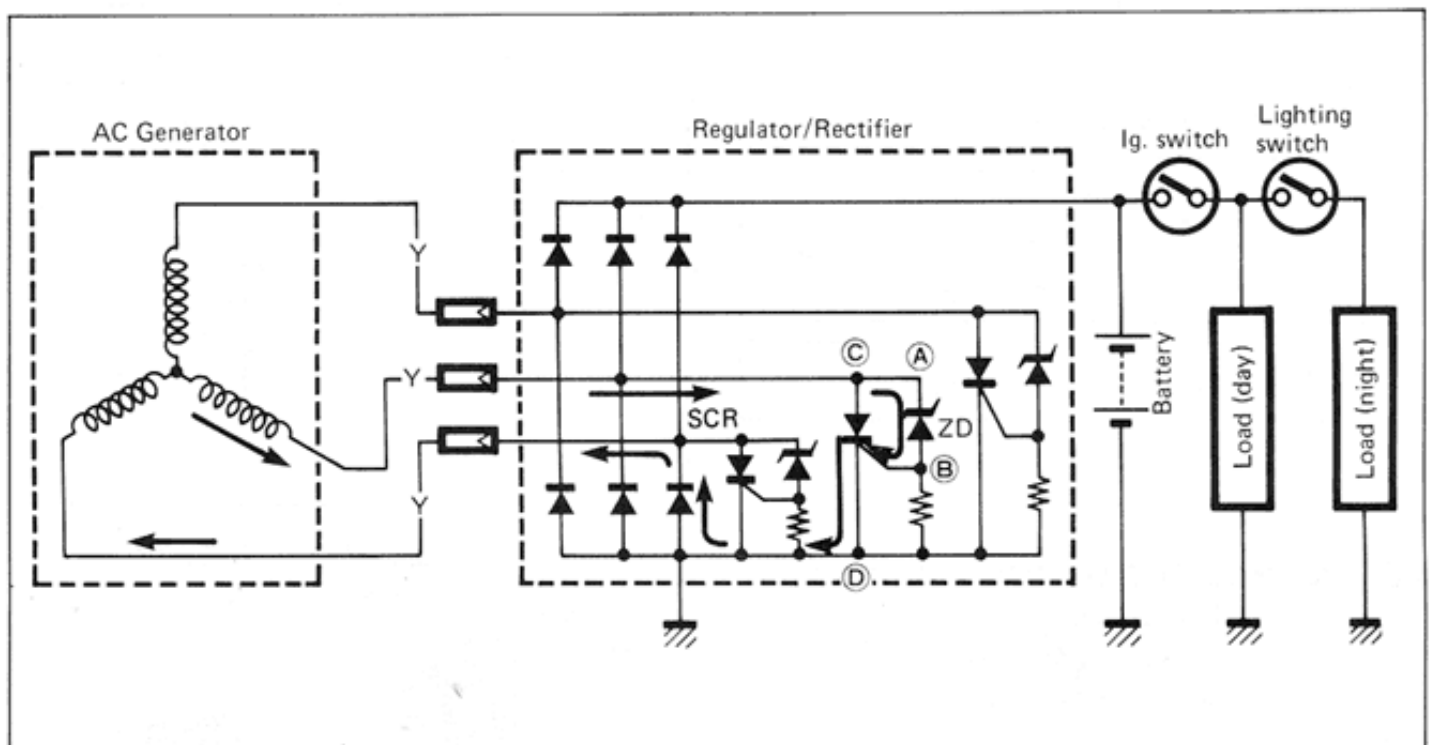

## INSPECTION

### CHARGING OUTPUT CHECK

- Remove the seat, frame covers and fuel tank.
- Start the engine and keep it running at 5 000 r/min with lighting switch turned ON and dimmer switch turned HI position.
- Using the pocket tester, measure the DC voltage between the battery terminal  $\oplus$  and  $\ominus$ .  
If the tester reads under 13.5V or over 15.5V, check the AC generator no-load performance and regulator/rectifier.

**NOTE:**

When making this test, be sure that the battery is fully-charged condition.

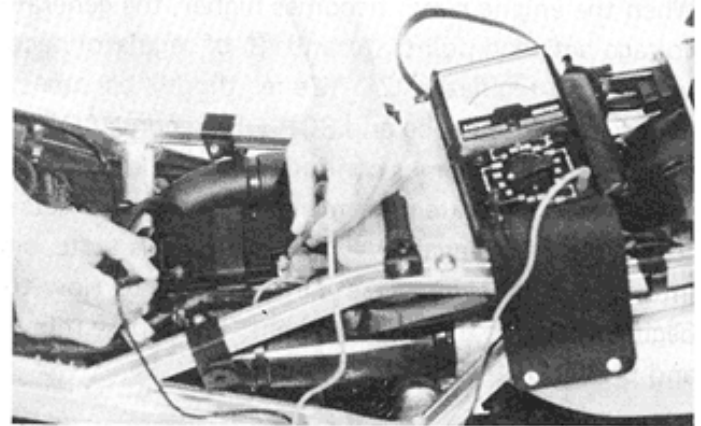

STD charging output	13.5 – 15.5 V (DC) at 5 000 r/min
09900-25002	Pocket tester

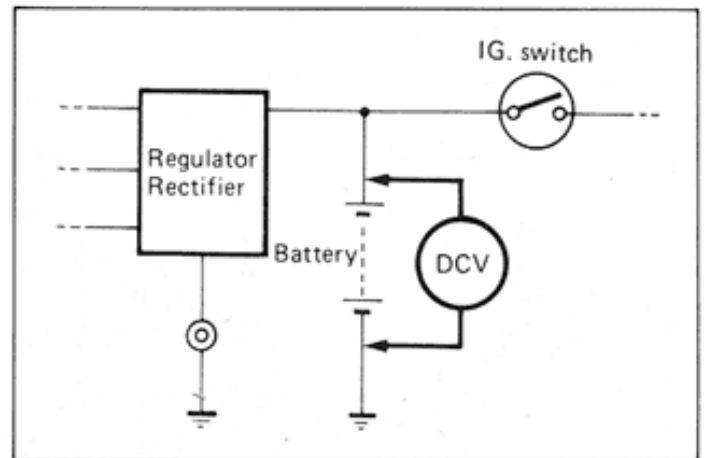

### AC GENERATOR NO-LOAD PERFORMANCE

- Remove the left fairing.
- Disconnect the AC generator lead wire coupler.
- Start the engine and keep it running at 5 000 r/min.
- Using the pocket tester, measure the AC voltage between the three yellow lead wires.  
If the tester reads under 53V, the AC generator is faulty.

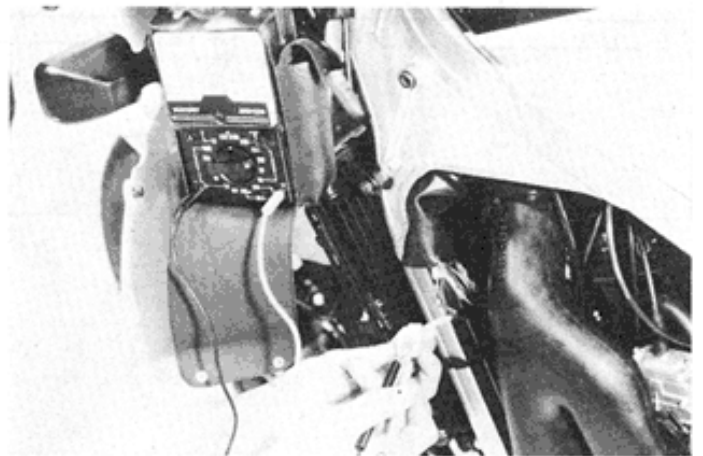

STD No-load performance	More than 53V (AC) at 5 000 r/min
09900-25002	Pocket tester

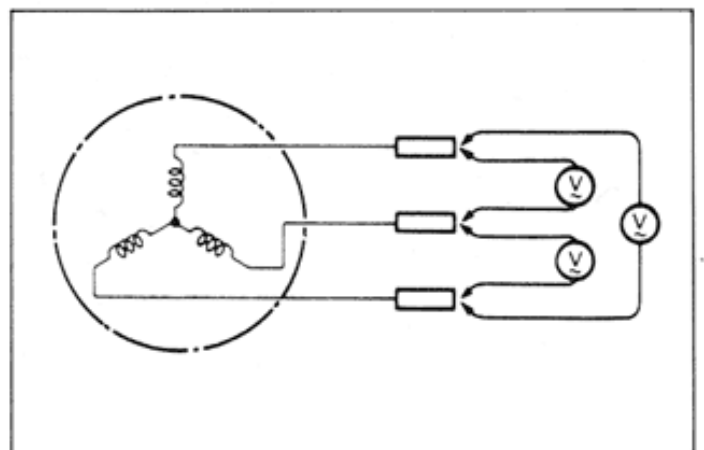

**AC GENERATOR CONTINUITY CHECK**

- Using the pocket tester, check the continuity between the Yellow lead wires of the stator.
- Also check that the stator core is insulated.

**NOTE:**

When making this test, it is not necessary to remove the AC generator.

09900-25002

Pocket tester

STD resistance

0.1 – 1.0  $\Omega$ **REGULATOR/RECTIFIER**

- Remove the seat, fuel tank, right and left frame covers.
- Remove the front fairing and windshield.
- Using the pocket tester (X 1k $\Omega$  range), measure the resistance between the lead wires in the following table.

If the resistance checked is incorrect, replace the regulator/rectifier.

09900-25002

Pocket tester

Unit: Approx. k $\Omega$ 

		⊕ Probe of tester to:				
		R	B/W	Y	Y	Y
⊖ Probe of tester to:	R		$\infty$	$\infty$	$\infty$	$\infty$
	B/W	8.5		3	3	3
	Y	3	$\infty$		$\infty$	$\infty$
	Y	3	$\infty$	$\infty$		
	Y	3	$\infty$	$\infty$	$\infty$	

**CAUTION:**

As transistors, capacitors, Zener diodes, etc. are used inside this regulator/rectifier, the resistance values will differ when an ohmmeter other than the Suzuki pocket tester is used.

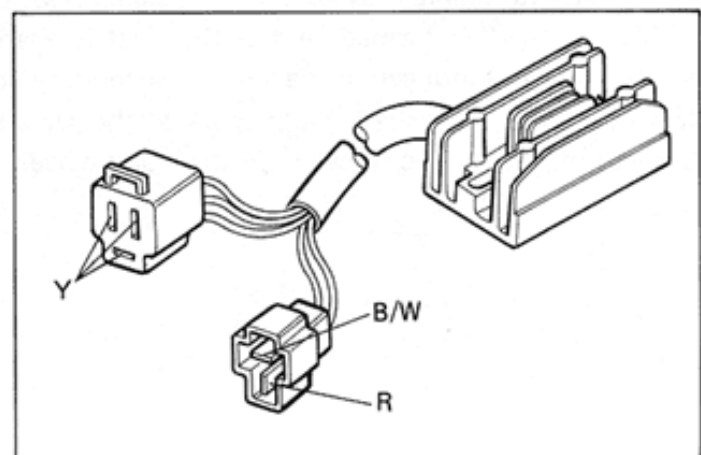
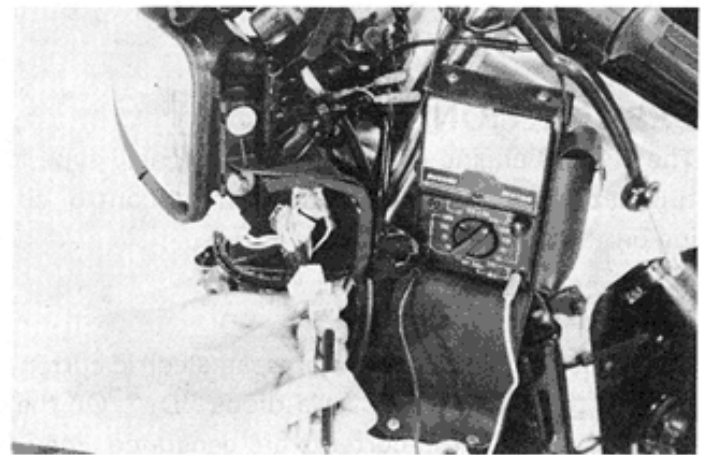
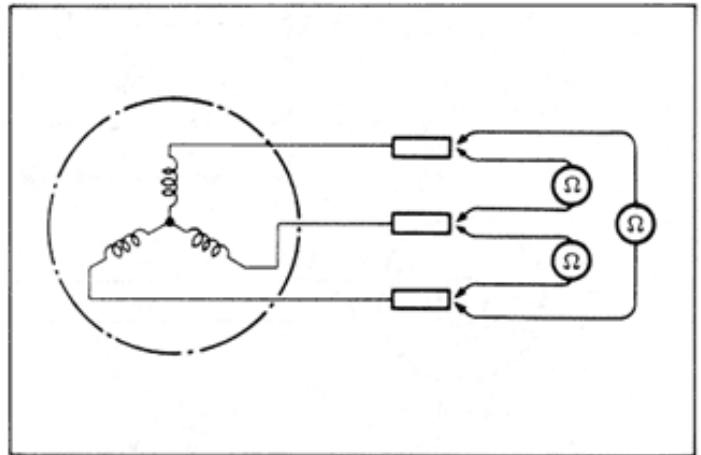

## IGNITION SYSTEM

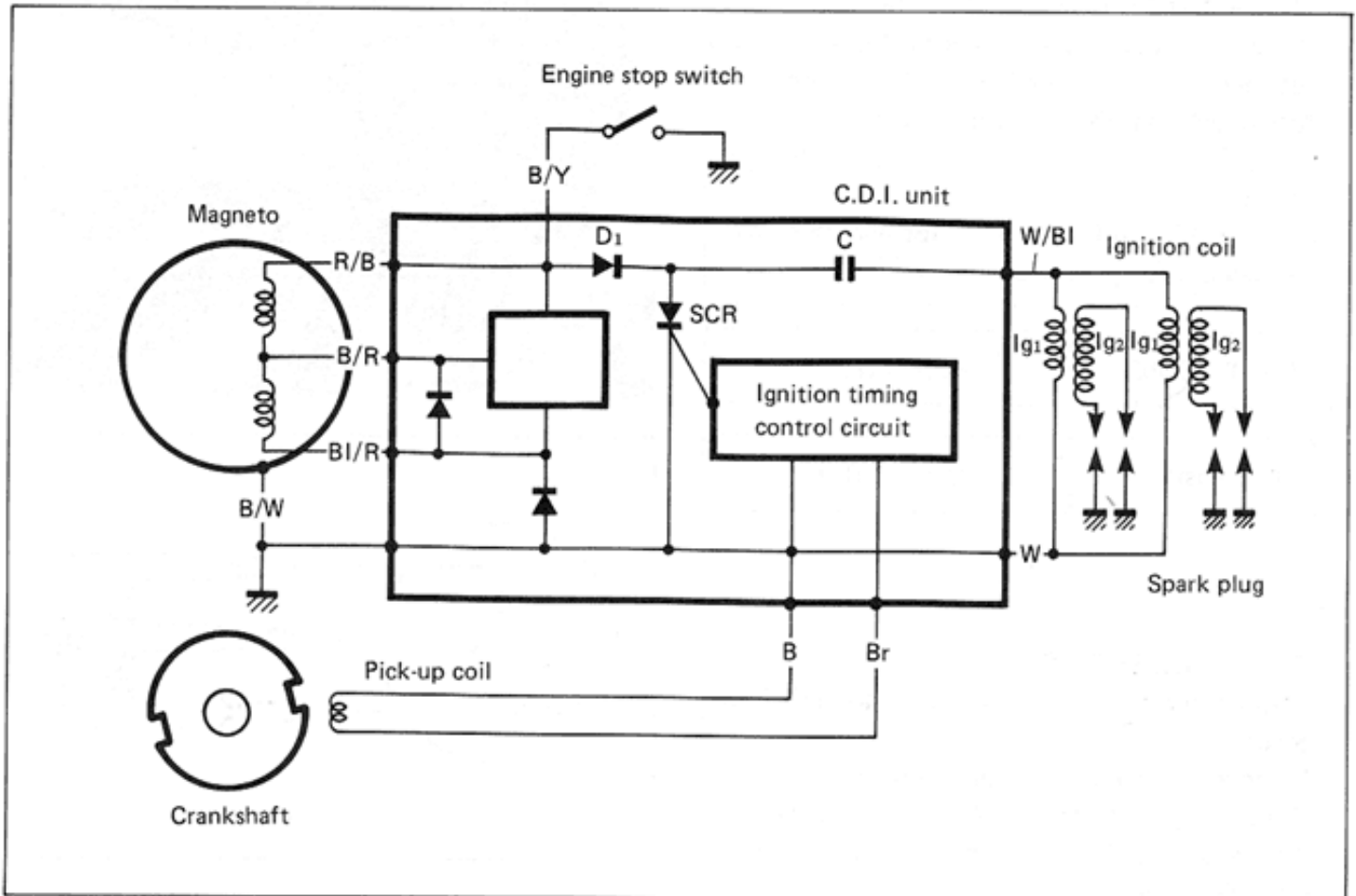

### DESCRIPTION

The RG500 engine is equipped with a new type ignition system. This new system further reduces timing fluctuations. It has an "ignition timing control circuit" which accurately controls ignition timing depending on the engine r/min.

### OPERATION

When the magneto rotor rotates, an electric current is generated in the power source coils, and this current charges the capacitor "C" via diode "D<sub>1</sub>". On the other hand, when the groove on the crank wheel passes the pick-up coil, the currents are generated, they flow to the ignition timing control circuit, and they are converted into one ignition signal. This signal is sent to "SCR", the "SCR" becomes ON, the circuit "C" → "SCR" → "Ig<sub>1</sub>" is formed, and as the electric energy stored in the capacitor "C" is discharged instantly, a high voltage is induced in the ignition secondary coil "Ig<sub>2</sub>", and a spark crosses over the spark plug gap. In this manner four spark plugs spark at the same time and two sparks occur by one crankshaft rotation because of two grooves located on the crank wheel.

## INSPECTION

### IGNITION COILS (Checking with Electro Tester)

- Remove the seat and fuel tank.
- Remove the ignition coils from the frame.
- Using the electro tester, test each ignition coil for sparking performance. The test connection is as indicated. Make sure that the three-needle sparking distance is at least 8 mm.

If no sparking or orange color sparking occurs with this much gap, then it is defective and must be replaced.

09900-28106	Electro tester
-------------	----------------

STD Spark performance	8 mm (0.3 in)
-----------------------	---------------

### IGNITION COILS (Checking with Pocket Tester)

- A SUZUKI pocket tester or an ohm meter may be used, instead of the electro tester. In either case, the ignition coil is to be checked for continuity in both primary and secondary windings. Exact ohmic readings are not necessary, but, if the windings are in sound condition, their continuity will be noted with these approximate ohmic values.

09900-25002	Pocket tester
-------------	---------------

Ignition coil resistance	
Primary	0.1 – 1.0 $\Omega$
Secondary	10 – 30 k $\Omega$

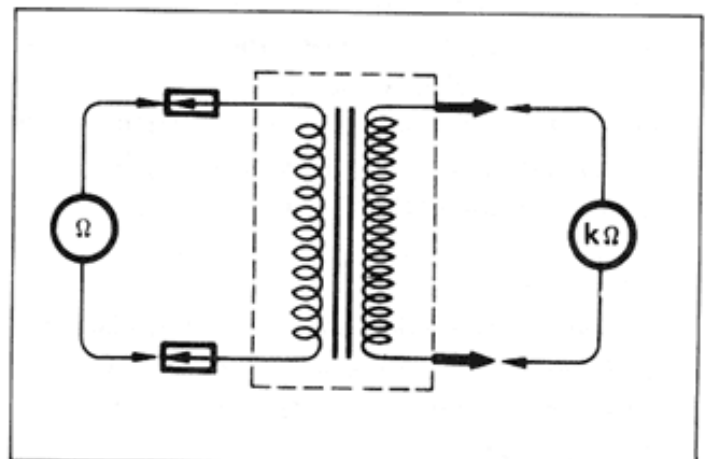
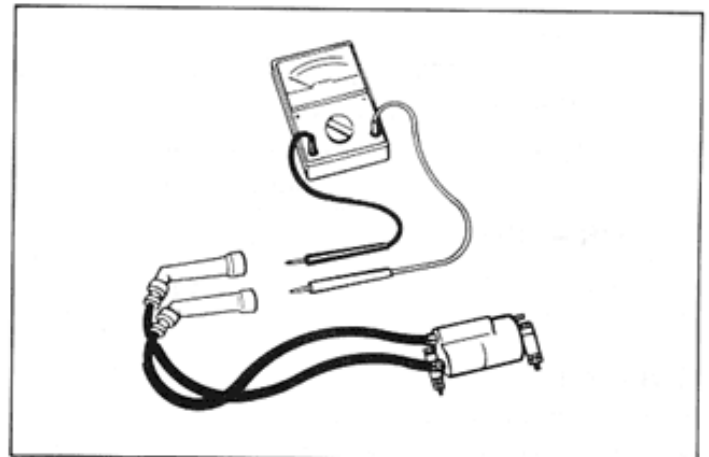
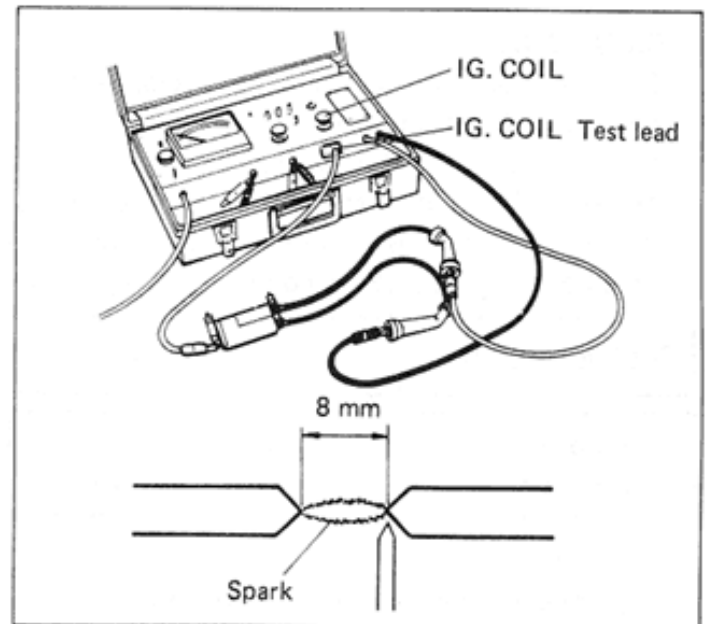

**PICK-UP COIL**

- Remove the right fairing and disconnect the pick-up coil lead coupler.
- Using a pocket tester ( $\times 100 \Omega$ ) measure the resistance between Black and Brown lead wires. If the resistance is infinity or less than the specification, the pick-up coil must be replaced.

09900-25002	Pocket tester
-------------	---------------

Pick-up coil STD resistance	85 – 135 $\Omega$ (Black – Brown)
--------------------------------	--------------------------------------

**STATOR COILS**

- Disconnect the magneto lead wire coupler.
- Using a pocket tester, measure the resistance of the stator coils.
- Replace the stator coil if the measurement is not within the specification.

	Standard resistance
B/R – BI/R	105 – 160 $\Omega$
B/R – R/B	3 – 5 $\Omega$

**CDI UNIT**

- Remove the pillion seat.
- Use the Suzuki pocket tester, bring the  $\oplus$  probe and the  $\ominus$  probe into contact with each lead wire of the CDI unit, check for continuity, and measure the resistance value.
- When the continuity and the resistance values are as shown in the following table, it can be judged that the CDI unit is normal.

**CAUTION:**

As capacitors, diodes, etc. are used inside this CDI unit, the resistance values will differ when an ohmmeter other than Suzuki pocket tester is used.

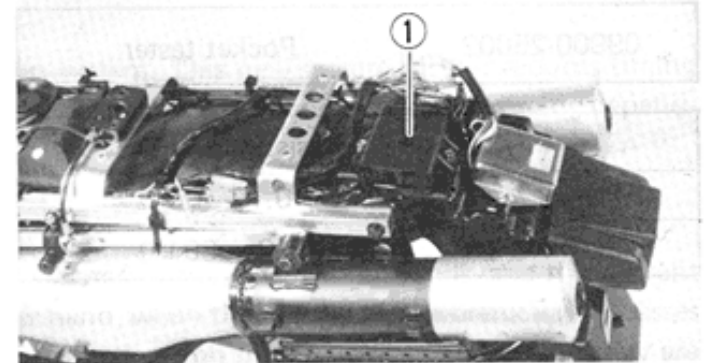
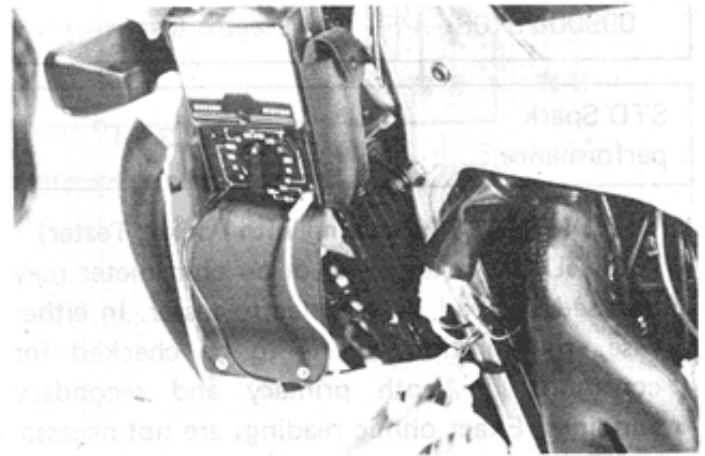

① CDI unit

Unit: k $\Omega$ 

		⊕ Probe of tester to:								
		R/B	B/R	BI/R	B	Br	W/BI	B/Y	W	B/W
⊖ Probe of tester to:	R/B		OFF	OFF	OFF	OFF	OFF	2-8	OFF	OFF
	B/R	OFF		OFF	OFF	OFF	OFF	OFF	OFF	OFF
	BI/R	OFF	25-1000		25-200	7-45	OFF	OFF	7-45	7-45
	B	OFF	25-100	10-40		4-18	OFF	OFF	4-18	4-18
	Br	OFF	6-26	2-8	3-13		OFF	OFF	0	0
	W/BI	OFF	19-80	6-25	8-32	2-8		OFF	2-8	2-8
	B/Y	OFF	OFF	OFF	OFF	OFF	OFF		OFF	OFF
	W	OFF	6-26	2-8	3-13	0	OFF	OFF		0
	B/W	OFF	6-26	2-8	3-13	0	OFF	OFF	0	

## AUTOMATIC EXHAUST CONTROL UNIT AND ACTUATOR DIAGRAM

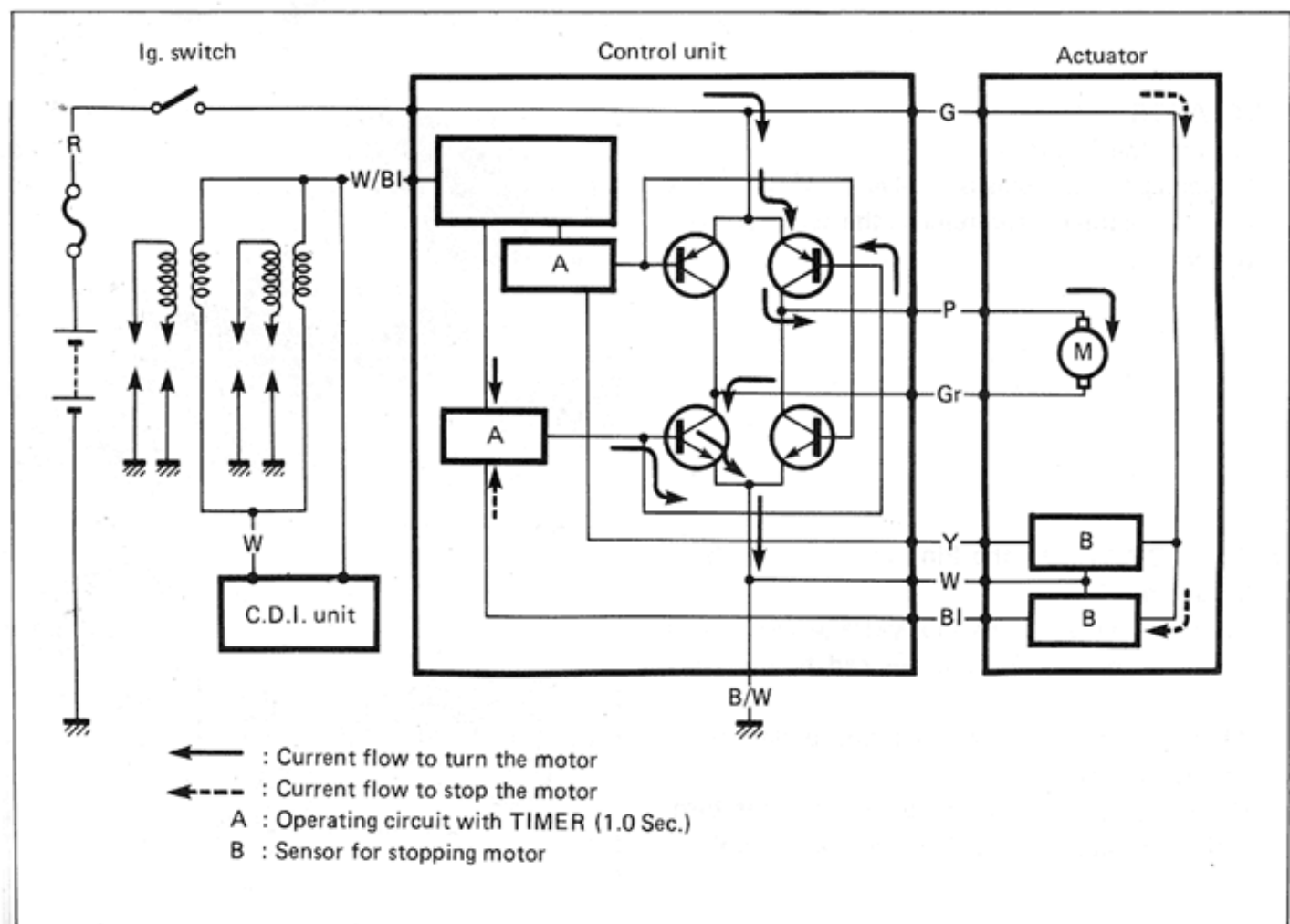

**INSPECTION****EXHAUST VALVE OPERATION**

- Remove the right fairing.
- Remove the exhaust valve pulley cover from the No. 2 cylinder.
- Start the engine and increase the engine r/min. to check the exhaust valve operation.

Exhaust valve	Engine r/min
Open → Close	7 800 r/min.
Close → Open	7 500 r/min.

- If the exhaust valve does not operate at the specified r/min, inspect the individual parts for any defect.

**ACTUATOR**

- Remove the fuel tank.
- Disconnect the exhaust valve control cables from the actuator and remove the actuator from the chassis.

- Apply DC 12V to the Pink and Gray leads of the actuator.
- Actuator pulley turns clockwise when ⊕ lead connects to the Pink and ⊖ lead to the Gray lead.
- When reversing the connection, pulley turns counterclockwise.
- If the actuator shaft or pulley does not turn, replace the actuator assembly with a new unit.

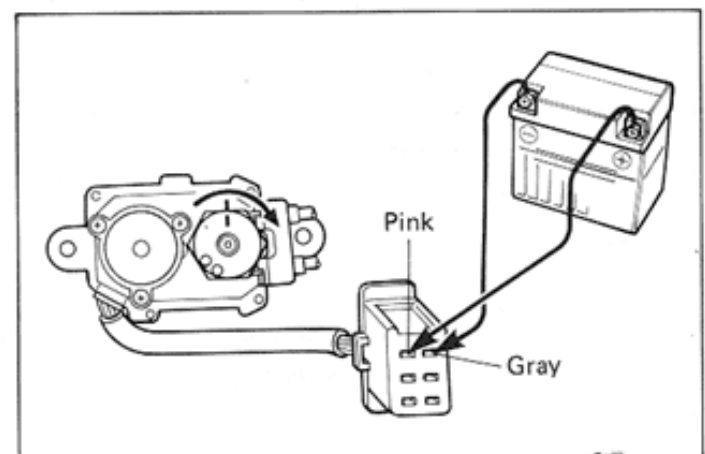
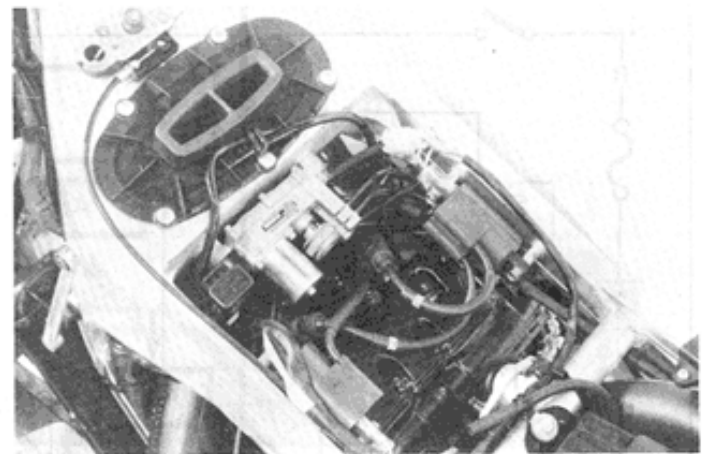
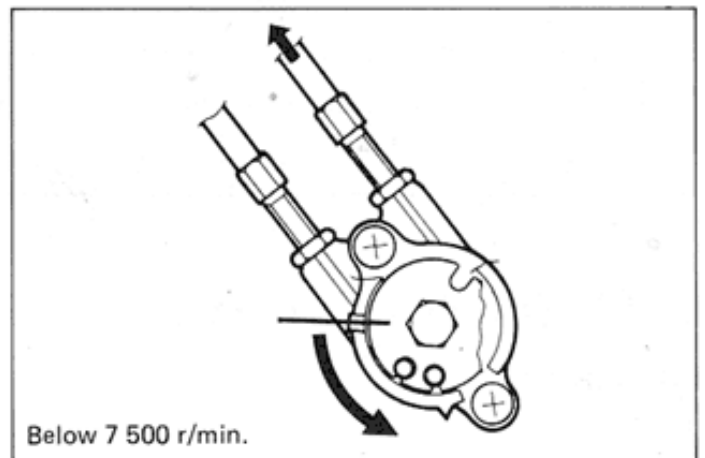
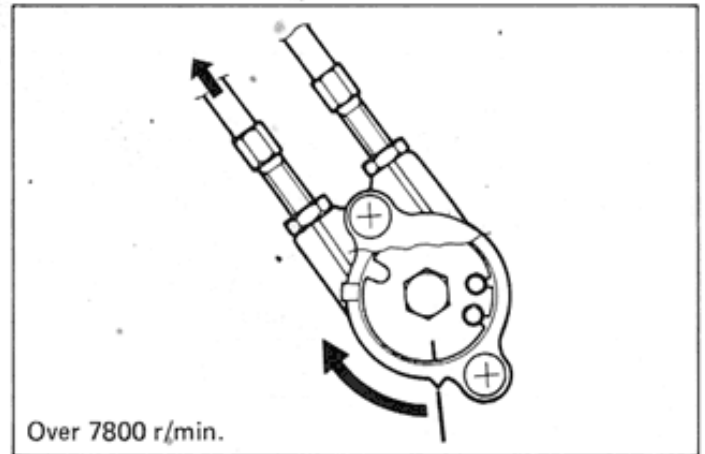

- Apply DC12V to the Green lead and White lead of the actuator. Connect the  $\oplus$  positive terminal of the battery to the Green lead and  $\ominus$  negative terminal to the White lead of the actuator.
- Using a pocket tester (x k $\Omega$  range) check the continuity between White and Yellow leads while turning the actuator pulley slowly by hand. Connect  $\oplus$  probe of tester to the White lead and  $\ominus$  probe to the Yellow lead. If there is no continuity point in one rotation of the pulley, stopper sensor in the actuator is defective and replace the actuator with a new one.
- Check the continuity between White and Blue leads in the same manner prescribed above. Connect the  $\oplus$  probe of tester to White lead and  $\ominus$  probe to Blue lead.

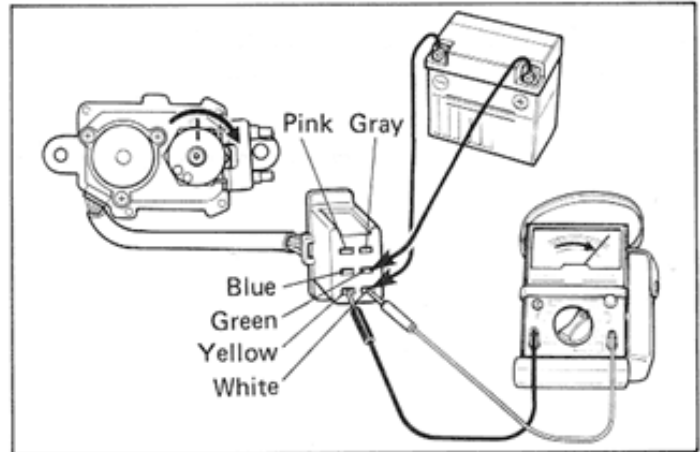

### ACTUATOR PULLEY

- When reinstalling the pulley to the pulley shaft, turn the pulley shaft and bring the engraved line ① on the shaft end to right side by 36 degree to the index mark ② on the actuator body.
- Install the pulley to the shaft so that the aligning mark ③ on the pulley meets the index mark ②.

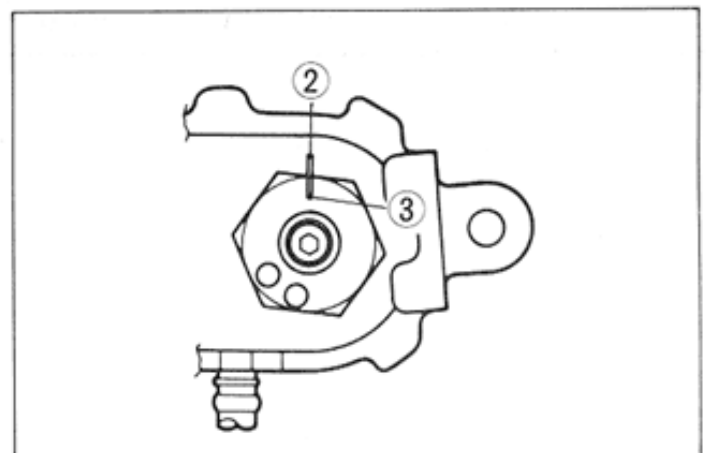
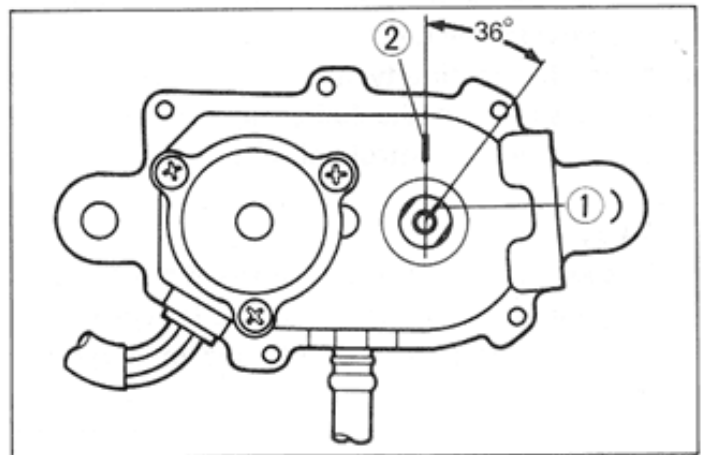

#### NOTE:

When connecting the exhaust valve control cables to the actuator, make sure that the pulley should be kept at the right figure and all exhaust valves should be opened.

**EXHAUST VALVE CONTROL UNIT**

- Remove the seat and pillion seat.
- Remove the rear cover.
- Disconnect the couplers and remove the control unit ①.

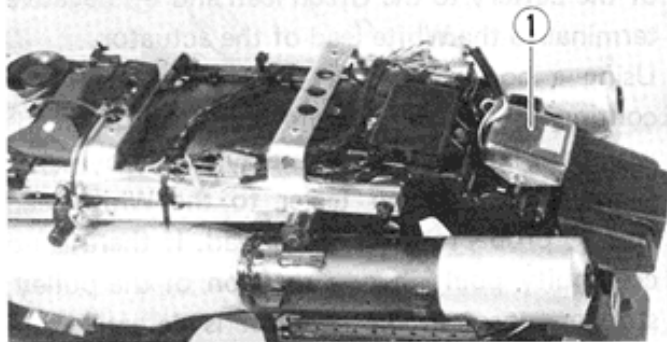

- Use a SUZUKI pocket tester (x 25 DCV) and connect the  $\oplus$  and  $\ominus$  probe pins to Gray and Pink leads respectively.
- Apply 12V (DC) to the Orange  $\oplus$  and Black/White  $\ominus$ .
- If the tester shows 8 – 12V for approx. one second, control unit is in good condition about TIMER circuit and motor driving circuit.
- Further inspection is needed.
- Use the Suzuki pocket tester, bring the  $\oplus$  probe and the  $\ominus$  probe into contact with each lead wire of the control unit, check for continuity, and measure the resistance value.
- When the continuity and the resistance values are as shown in the following table, it can be judged that the control unit is normal.

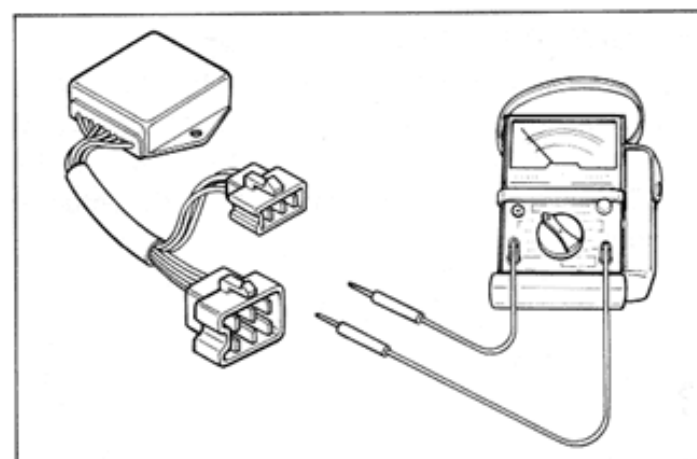
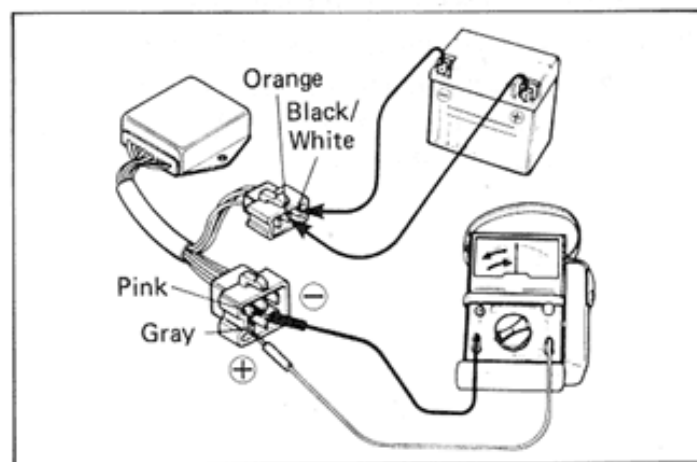
**CAUTION:**

As capacitors, diodes, etc. are used inside this unit, the resistance values will differ when an ohmmeter other than Suzuki pocket tester is used.

09900-25002

SUZUKI Pocket tester

Unit: Approx.  $k\Omega$ 

		⊕ Probe of tester to:								
		W/BI	Y	Gr	P	W	B/W	BI	G	O
⊖ Probe of tester to:	W/BI		OFF	OFF	OFF	OFF	OFF	OFF	OFF	OFF
	Y	OFF		ON (3)	ON (3)	ON (2.4)	ON (2.4)	ON (5)	ON (7)	OFF
	Gr	OFF	OFF		ON (0)	OFF	OFF	OFF	OFF	OFF
	P	OFF	OFF	ON (0)		OFF	OFF	OFF	OFF	OFF
	W	OFF	ON (2.2)	ON (2.5)	ON (2.6)		ON (0)	ON (2.8)	ON (3.8)	OFF
	B/W	OFF	ON (2.2)	ON (2.5)	ON (2.6)	ON (0)		ON (2.8)	ON (3.8)	OFF
	BI	OFF	ON (5.1)	ON (3)	ON (3)	ON (3)	ON (3)		ON (8)	OFF
	G	OFF	ON (17)	ON (26)	ON (26)	ON (13)	ON (13)	ON (18)		OFF
	O	OFF	ON (40)	ON (8)	ON (8)	ON (30)	ON (30)	ON (40)	ON (3)	

## WATER TEMPERATURE METER

As shown in Fig. 1, four coils are located in the water Temp. meter ( $N_1$ ,  $N_2$ ,  $N_3$  and  $N_4$ ). As the resistance from the sending unit varies along with the coolant temperature, the current at points  $L_1$  and  $L_2$  will also vary. This in turn will cause the strength of the magnetic field generated in the four coils to increase or decrease (causing a related increase or decrease in the force vector  $H$  in Fig. 2) which will force the needle to move to the proper position (Fig. 3).

When the ignition switch is turned off, the pointer returns to the original position.

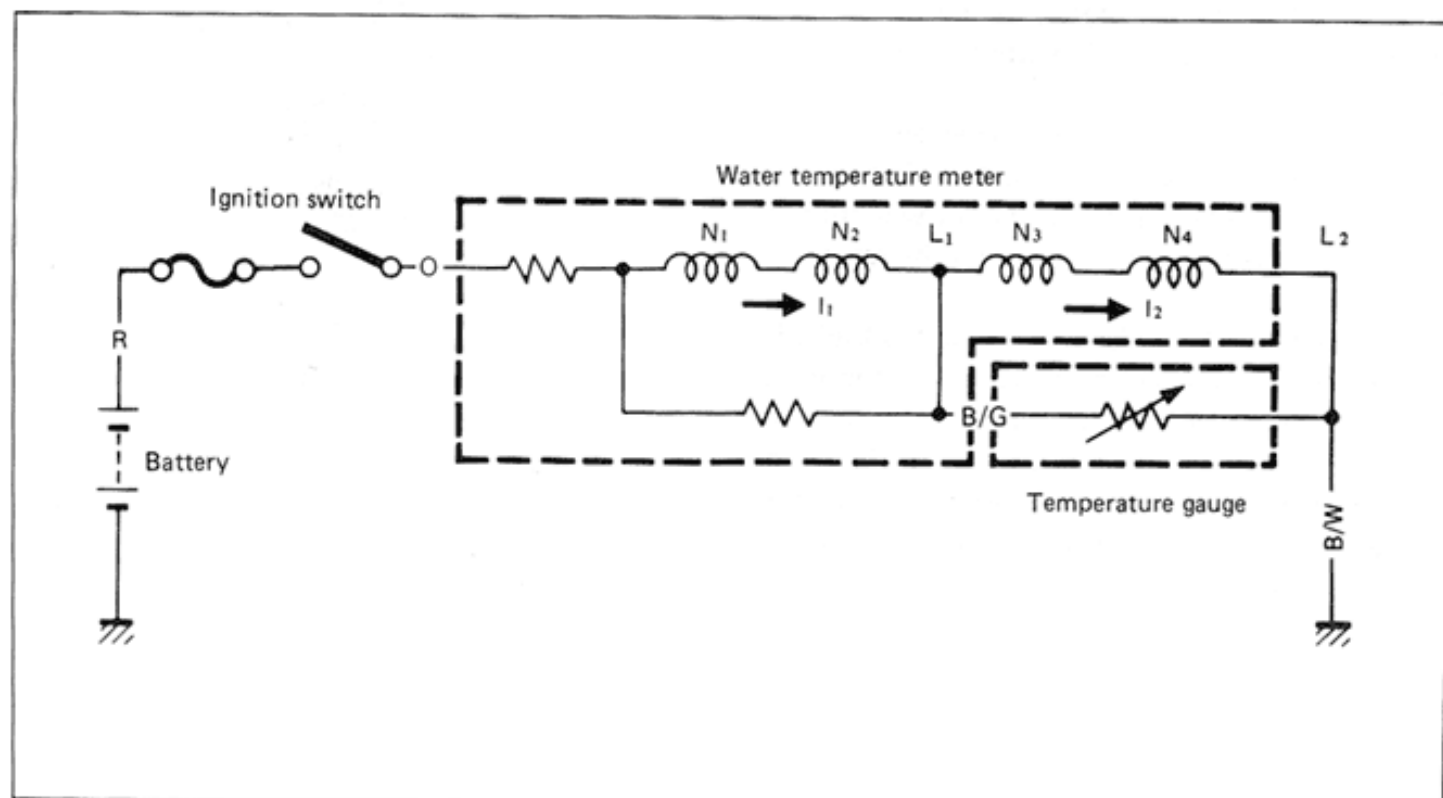

Fig. 1

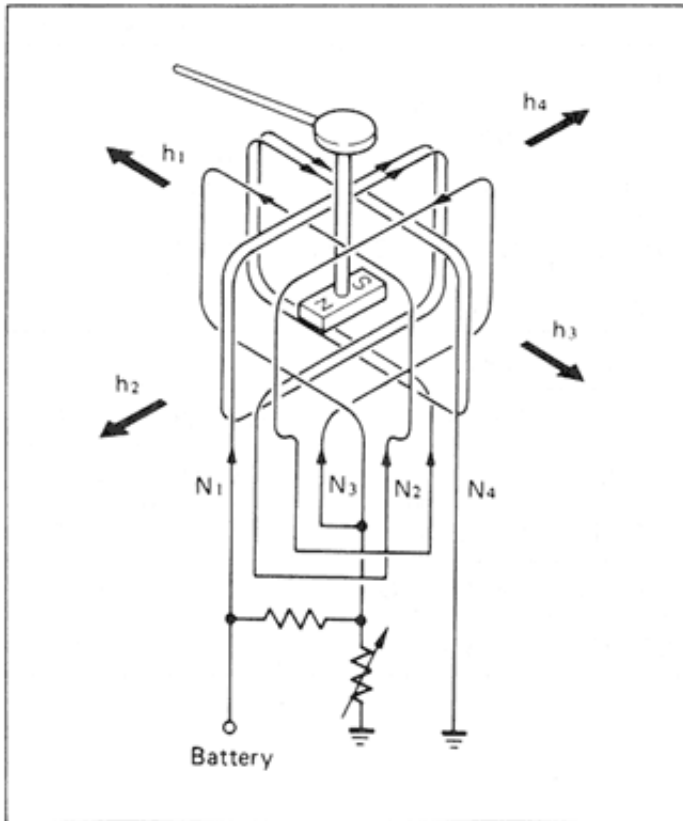

Fig. 3

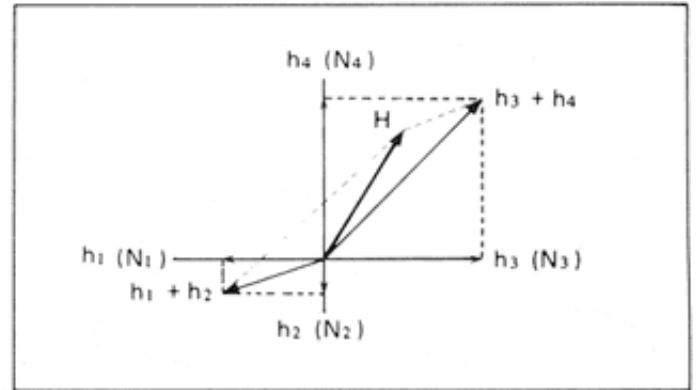

Fig. 2

### WATER TEMPERATURE METER INSPECTION

As the coil spring is installed on the needle shaft of the water temperature meter, the needle is forced back to the original position when ignition switch is turned OFF.

To test the water temperature meter two different checks may be used. The first, and simplest test will tell if the meter is operating but will not indicate the meters accuracy throughout the range.

To perform this test, disconnect the B/G lead wire of the water temperature meter from the water temperature gauge. Connect a jumper wire between B/G wires coming from the main wiring harness and engine ground. With the ignition switch turned on, the water temperature meter should indicate "H".

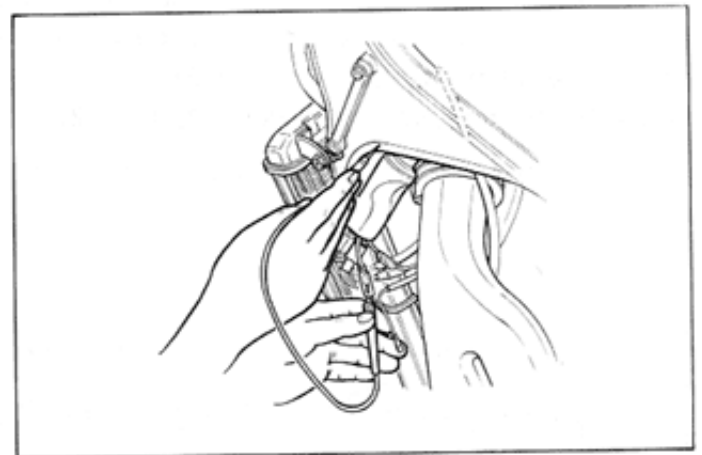

The second test will check the accuracy of the meter in the "H" and "C" positions.

Connect a 180-ohm resistor between the B/G lead wire of the water temperature gauge and the ground lead wire. The water temperature gauge is normal if its pointer indicates the C position when the specified voltage is applied to the circuit and if its pointer indicates the H position when the resistor is changed to 21 ohms. If either one or both indications are abnormal, replace the water temperature meter with a new one.

### WATER TEMPERATURE METER

POSITION	TEMP	RESISTANCE
①	56°C	180 Ω
②	124°C	21 Ω

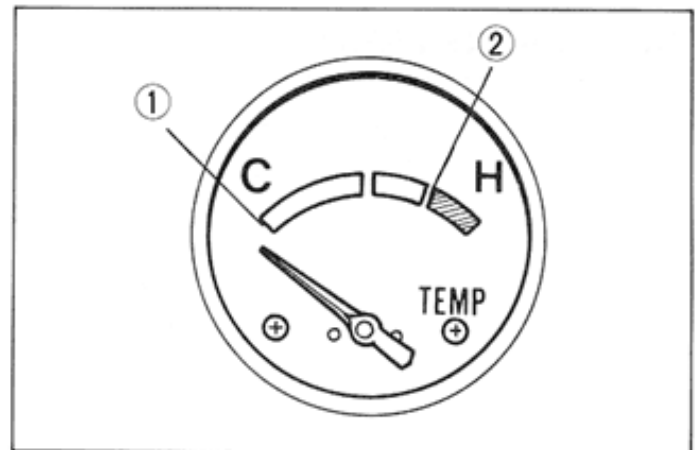
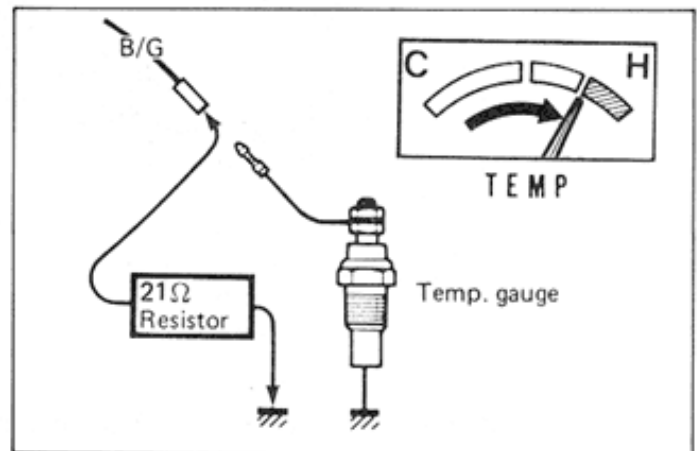
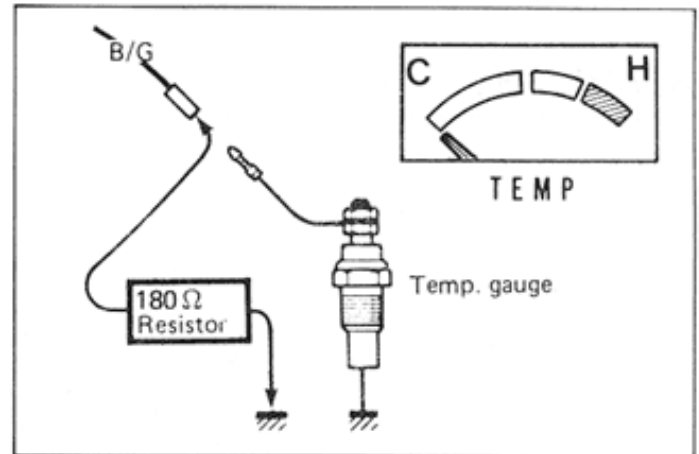

### OIL LEVEL GAUGE

Check the oil level switch for continuity between BI/W and B/W lead wires. If the tester does not show the value of 0 – 1 ohm when the switch ring is in bottom, file the contact surface or replace the unit.

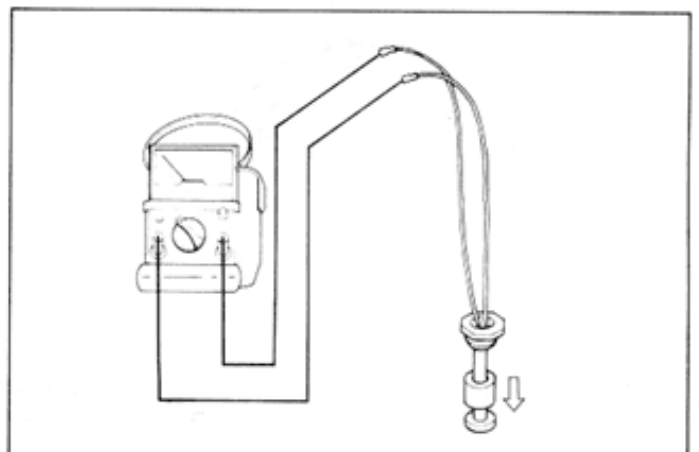

## LAMPS

### HEADLIGHT

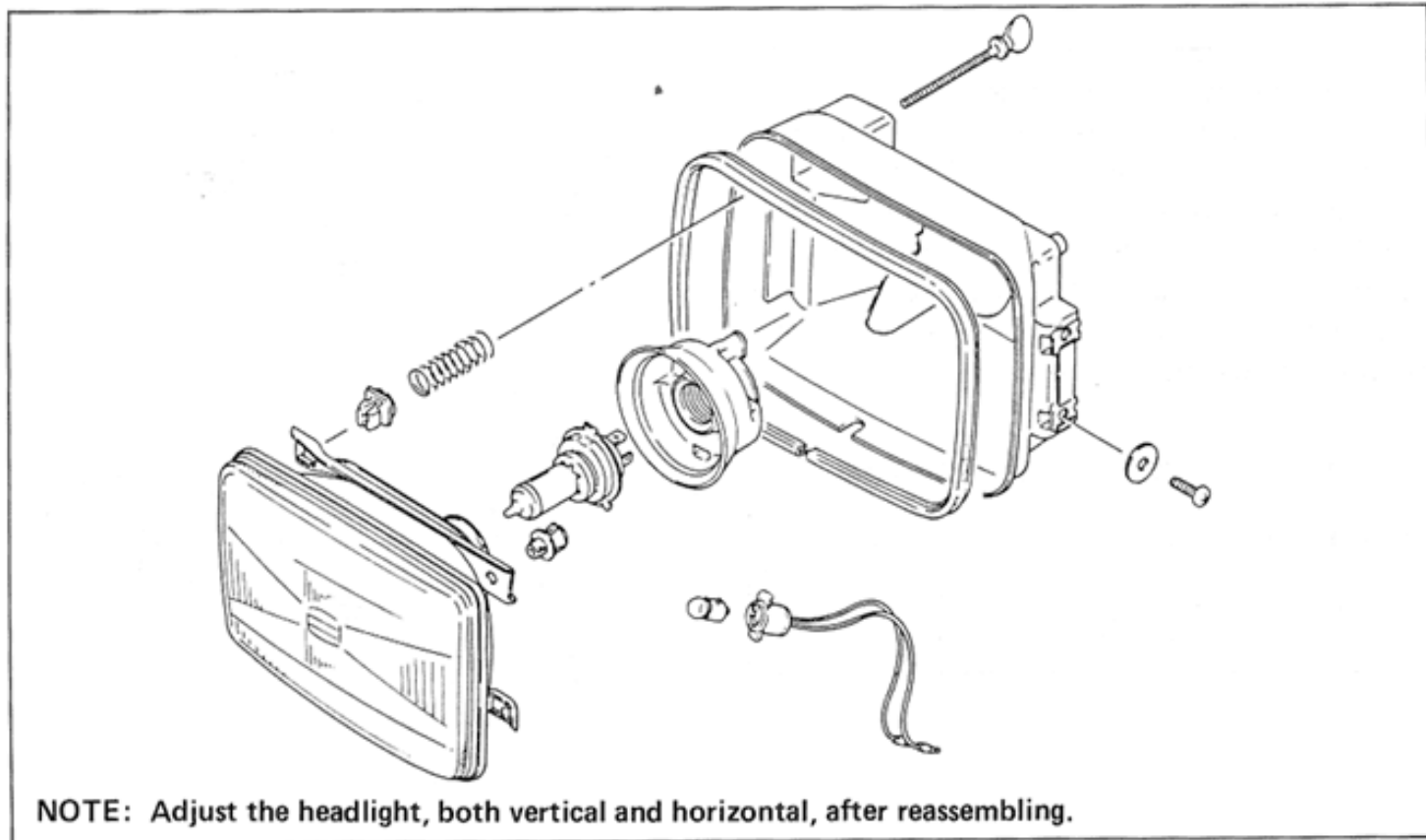

### TAIL / BRAKE LIGHT

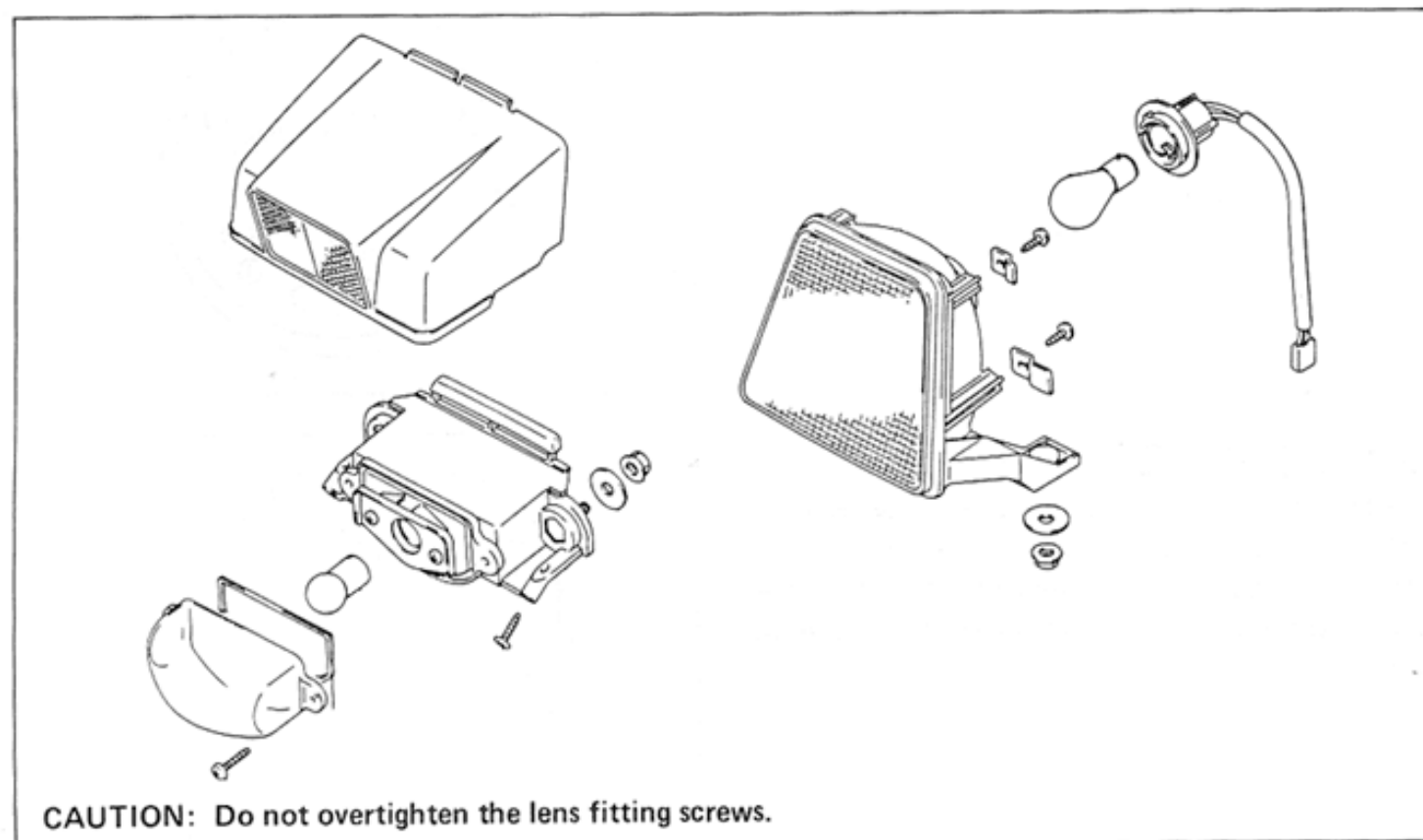

## TURN SIGNAL LIGHT

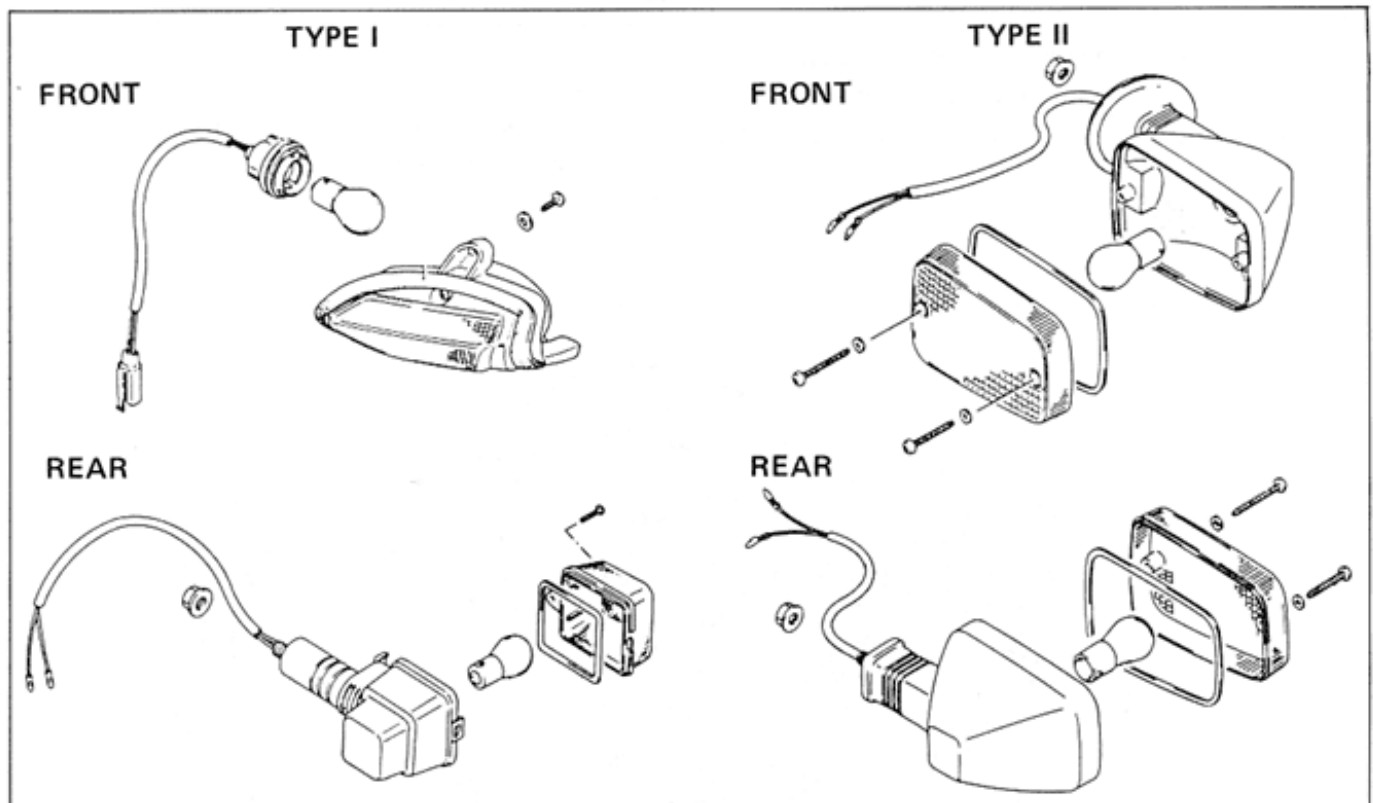

## SPEEDOMETER

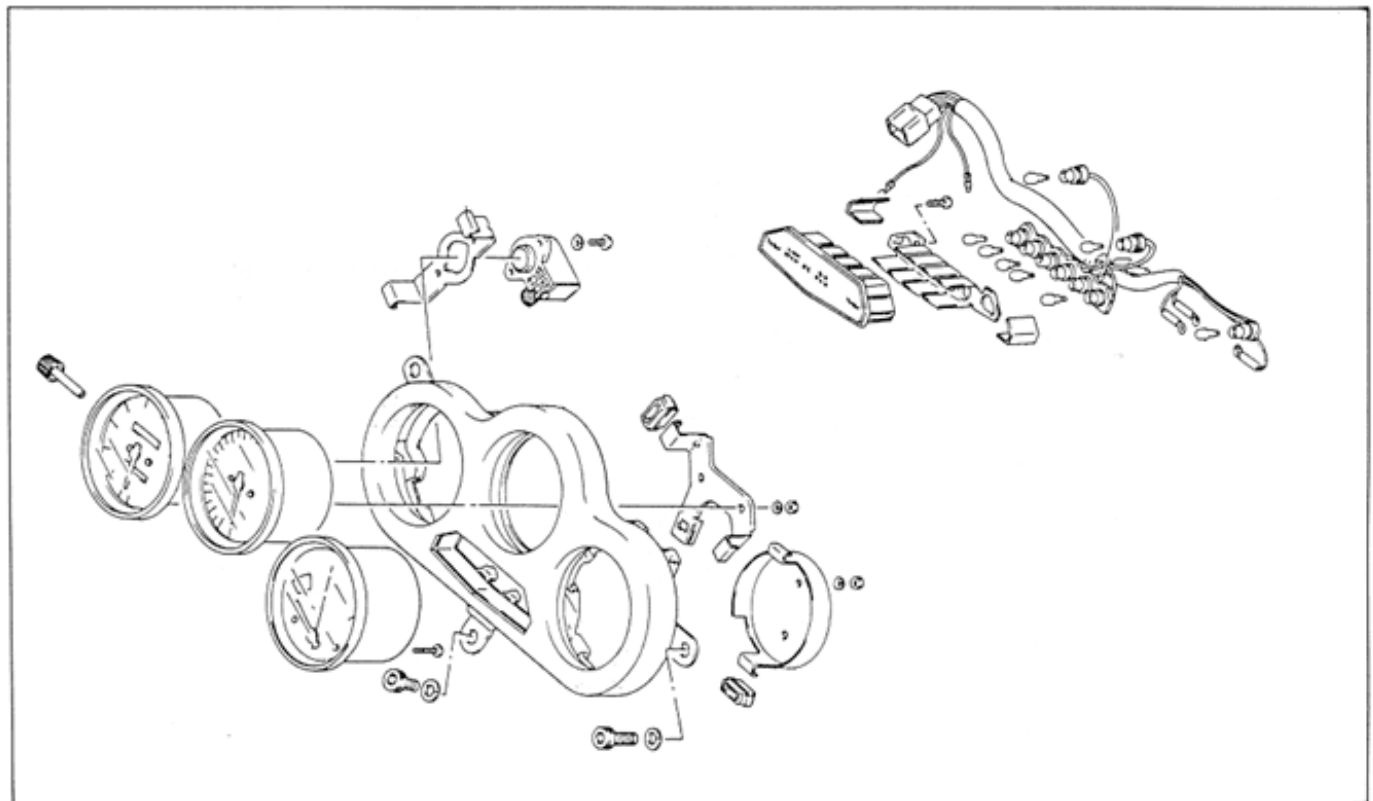

### SPEEDOMETER WIRING INSPECTION

Using the pocket tester, check the continuity between lead wires in the following diagram. If the continuity measured is incorrect, replace the respective parts.

09900-25002	Pocket tester
-------------	---------------

**NOTE:**  
When making this test, it is not necessary to remove the combination meter.

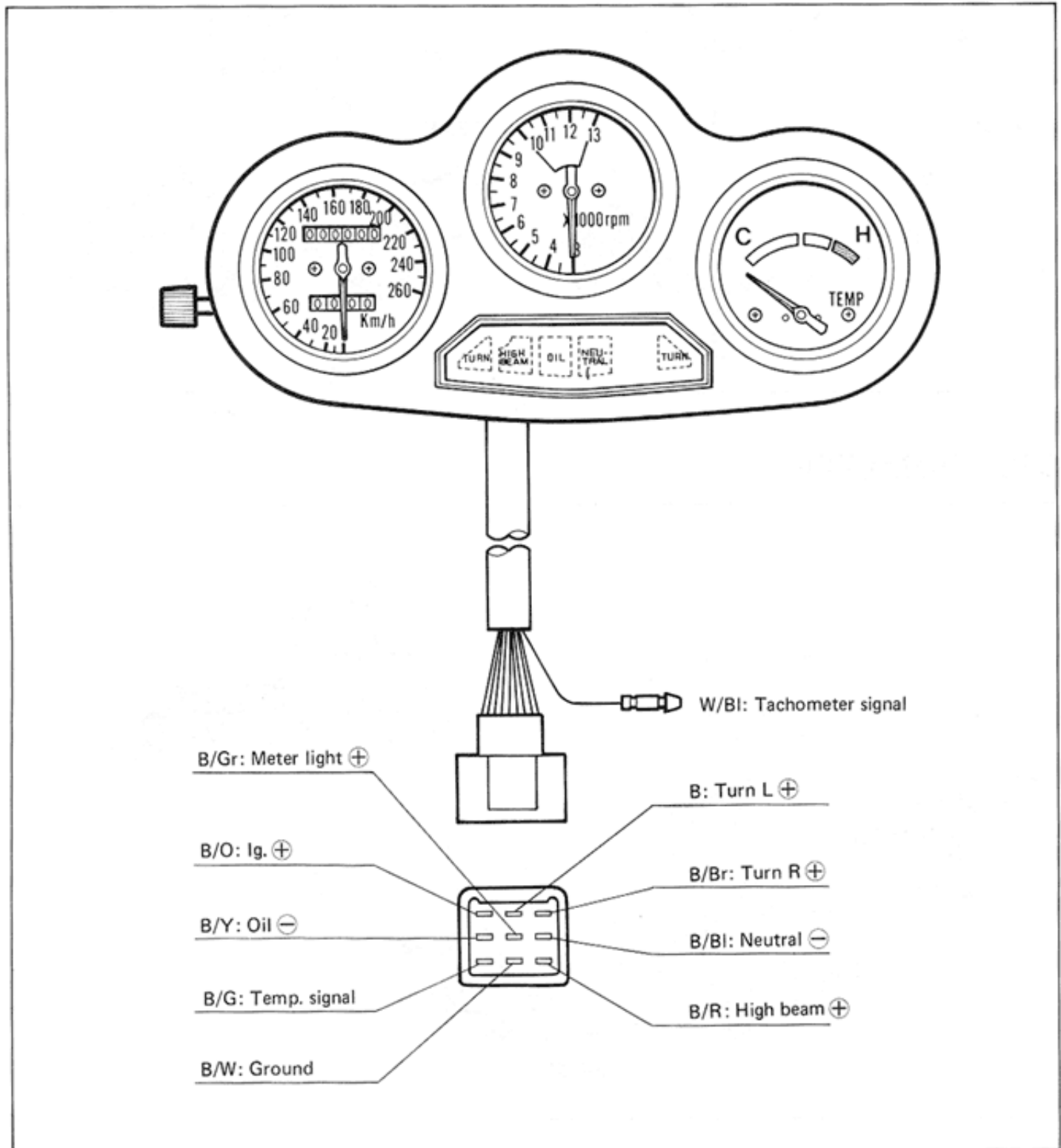

## SWITCHES

Inspect each switch for continuity with the pocket tester referring to the chart. If any abnormality is found, replace the respective switch assemblies with new ones.

09900-25002	Pocket tester
-------------	---------------

### IGNITION SWITCH

	B/R	B/W	Bl/W	R	O	Br	Gr
OFF	○—○						
C	○—○—○			○—○			
ON				○—○		○—○	
P	○—○			○—○			

### LIGHTING SWITCH (For E-1, 6 and 24)

	O	Gr	Y/W
OFF			
ON	○—○	○—○	○—○

### LIGHTING SWITCH (Except for Canada)

	O	Gr	Y/W
OFF			
S	○—○	○—○	
ON	○—○	○—○	○—○

### DIMMER SWITCH

	Y/W	Y	W
HI	○—○	○—○	
LO	○—○	○—○	○—○

### TURN SIGNAL LIGHT

	B	Lbl	Lg
R		○—○	○—○
•			
L	○—○	○—○	

### FRONT BRAKE SWITCH

	O	W/B
ON	○—○	○—○
OFF		

### REAR BRAKE SWITCH

	O	W/B
ON	○—○	○—○
OFF		

### NEUTRAL SWITCH

	Bl	Ground
Neutral position	○—○	○—○

### PASSING SWITCH (Except E28)

	O/R	Y
ON (Push)	○—○	○—○
OFF		

### HORN BUTTON

	G	B/W
ON (Push)	○—○	○—○
OFF		

### SIDE STAND SWITCH (Only for Canada)

	G/W	B/W
ON	○—○	○—○
OFF		

### WIRE COLOR

B : Black	B/R : Black with Red tracer
Bl : Blue	B/W : Black with White tracer
Br : Brown	Bl/W : Blue with White tracer
Gr : Gray	G/W : Green with White tracer
Lbl : Light blue	O/R : Orange with Red tracer
Lg : Light green	W/B : White with Black tracer
O : Orange	Y/W : Yellow with White tracer
R : Red	
W : White	
Y : Yellow	

## BATTERY

### SPECIFICATIONS

Type designation	YT5L-12
Capacity	12V, 14.4kC (4 Ah)/ 10HR
Standard electrolyte S.G.	1.32 at 20°C (68°F)

### INITIAL CHARGING

#### Filling electrolyte

- Remove the aluminum tape sealing the battery electrolyte filler holes.
- Hold the electrolyte container with its nozzles upright, and use wire cutters, etc. to cut out off the end of the nozzles at the designated locations (between the ends and the packing).
- Insert the nozzles of the electrolyte container into the battery's electrolyte filler holes, holding the container firmly so that it does not fall. Take precaution not to allow any of the fluid to spill.
- Use wire cutters to cut the protruding part on the bottom of each container, and leave in this position for about 10 minutes.

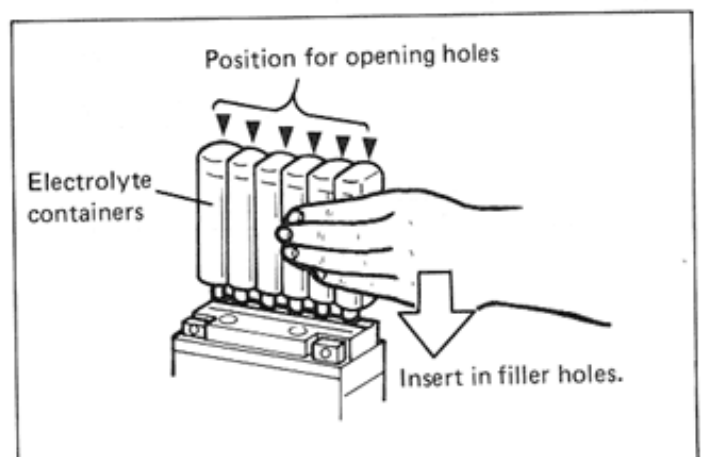
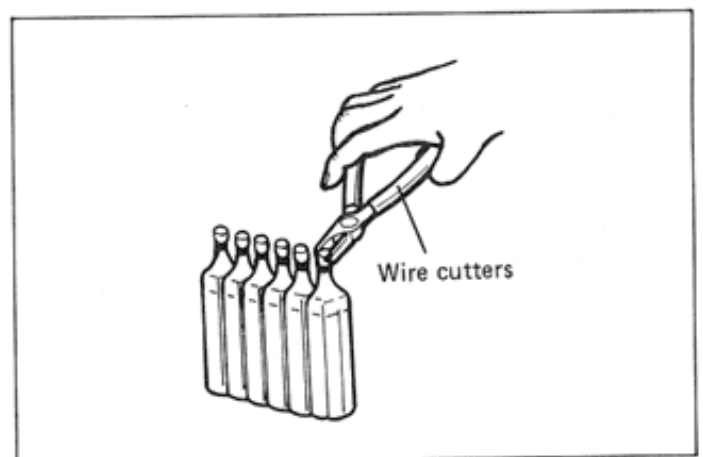
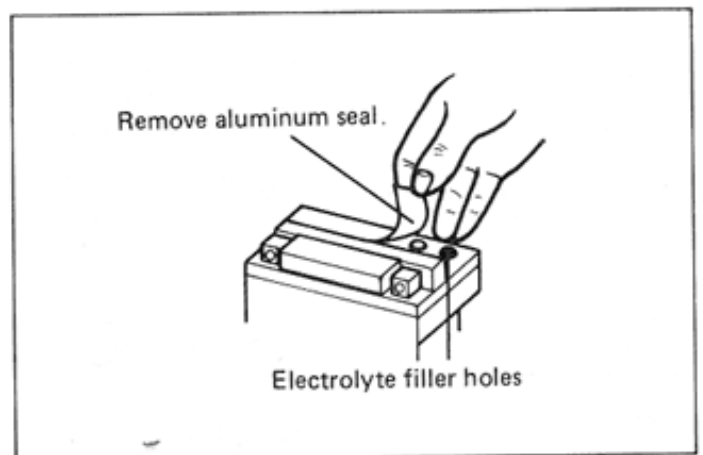
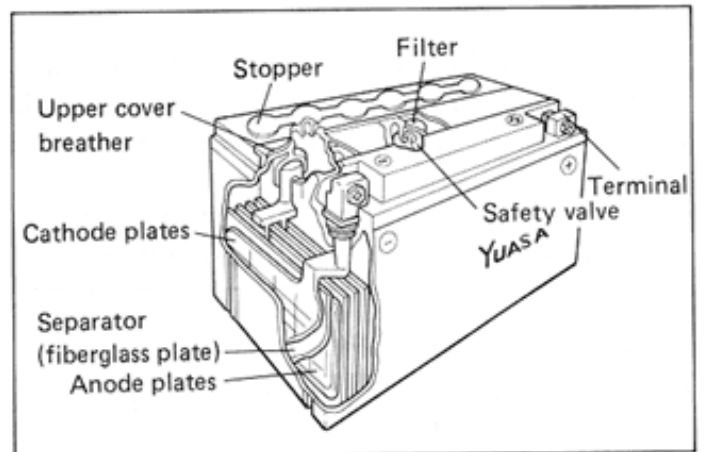

- After confirming that the electrolyte has entered the battery completely, remove the electrolyte containers from the battery. Wait for around 10 minutes.
- Insert the stoppers into the filler holes, pressing in firmly so that the top of the stoppers do not protrude above the upper surface of the battery's top cover.

**CAUTION:**

- \* Never use anything except the specified battery.
- \* Once install the stoppers to the battery, do not remove the stoppers.

- Using Suzuki pocket tester, measure the battery voltage. The tester should indicate more than 12.5 V (DC) as shown in the Fig. If the battery voltage is lower than the specification, charge the battery with a battery charger. (Refer to the recharging operation on page 6-21.)

**NOTE:**

Initial charging for a new battery is recommended if two years have elapsed since the date of manufacture.

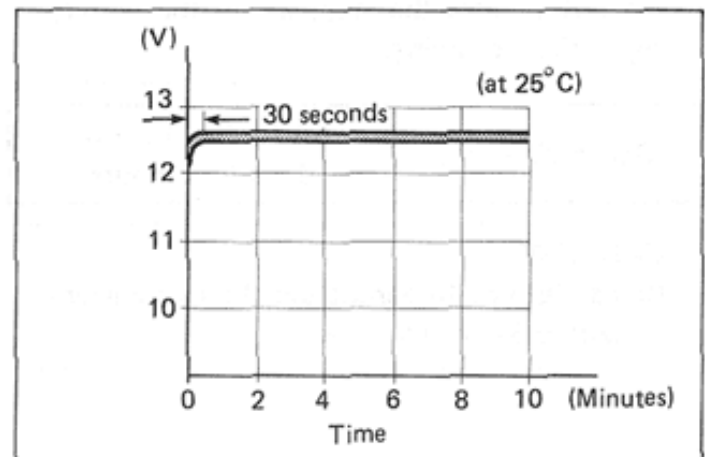
**SERVICING**

Visually inspect the surface of the battery container. If any signs of cracking or electrolyte leakage from the sides of the battery have occurred, replace the battery with a new one.

If the battery terminals are found to be coated with rust or an acidic white powdery substance, then this can be cleaned away with sandpaper.

## RECHARGING OPERATION

- Using the pocket tester, check the battery voltage. If the voltage reading is less than the 12.0V (DC), recharge the battery with a battery charger.

### CAUTION:

When recharging the battery remove the battery from the motorcycle.

### NOTE:

Do not remove the stoppers on the battery top while recharging.

Recharging time

5A for half hour or  
0.5A for 5 hours

### CAUTION:

Be careful not to permit the charging current to exceed 5A at any time.

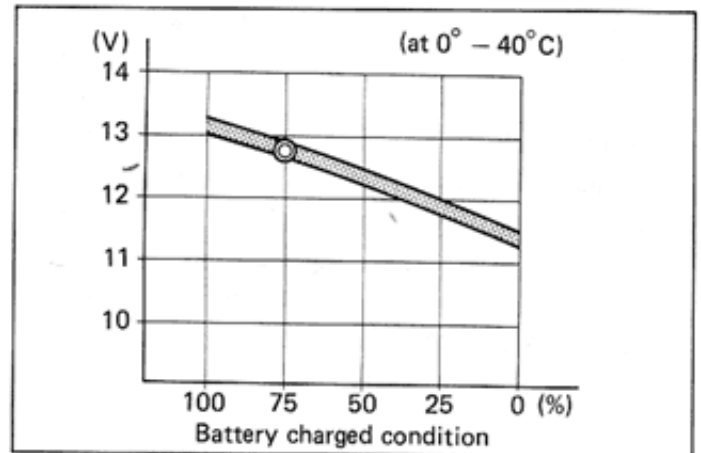
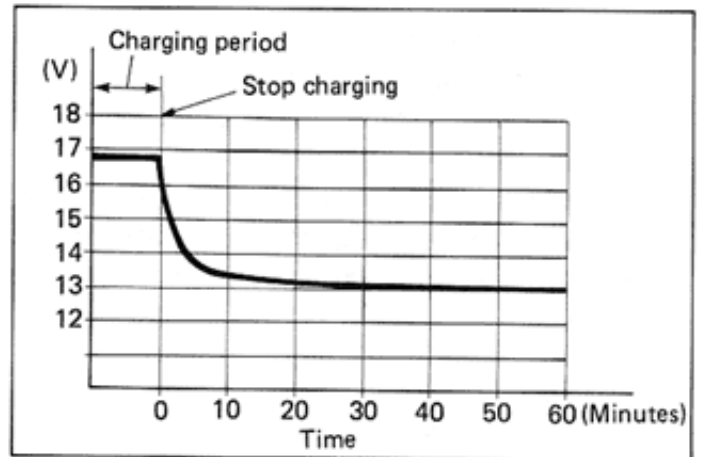

- After recharging, wait for more than 30 minutes and check the battery voltage with a pocket tester.
- If the battery voltage is less than the 12.5V, recharge the battery again.
- If battery voltage is still less than 12.5V after recharging, replace the battery with a new one.
- When a battery is left for a long term without using, it is subject to discharge. When the motorcycle is not used for more than 1 month (especially during the winter season), recharge the battery once a month at least.

# CHASSIS

## CONTENTS

<i>FAIRING</i> .....	7- 1
<i>FRONT WHEEL</i> .....	7- 4
<i>FRONT BRAKE</i> .....	7- 9
<i>FRONT FORK</i> .....	7-16
<i>STEERING STEM</i> .....	7-24
<i>REAR BRAKE</i> .....	7-29
<i>REAR WHEEL</i> .....	7-36
<i>TIRE AND WHEEL</i> .....	7-42
<i>REAR SWINGARM AND SUSPENSION</i> .....	7-48

# FAIRING

## CONSTRUCTION

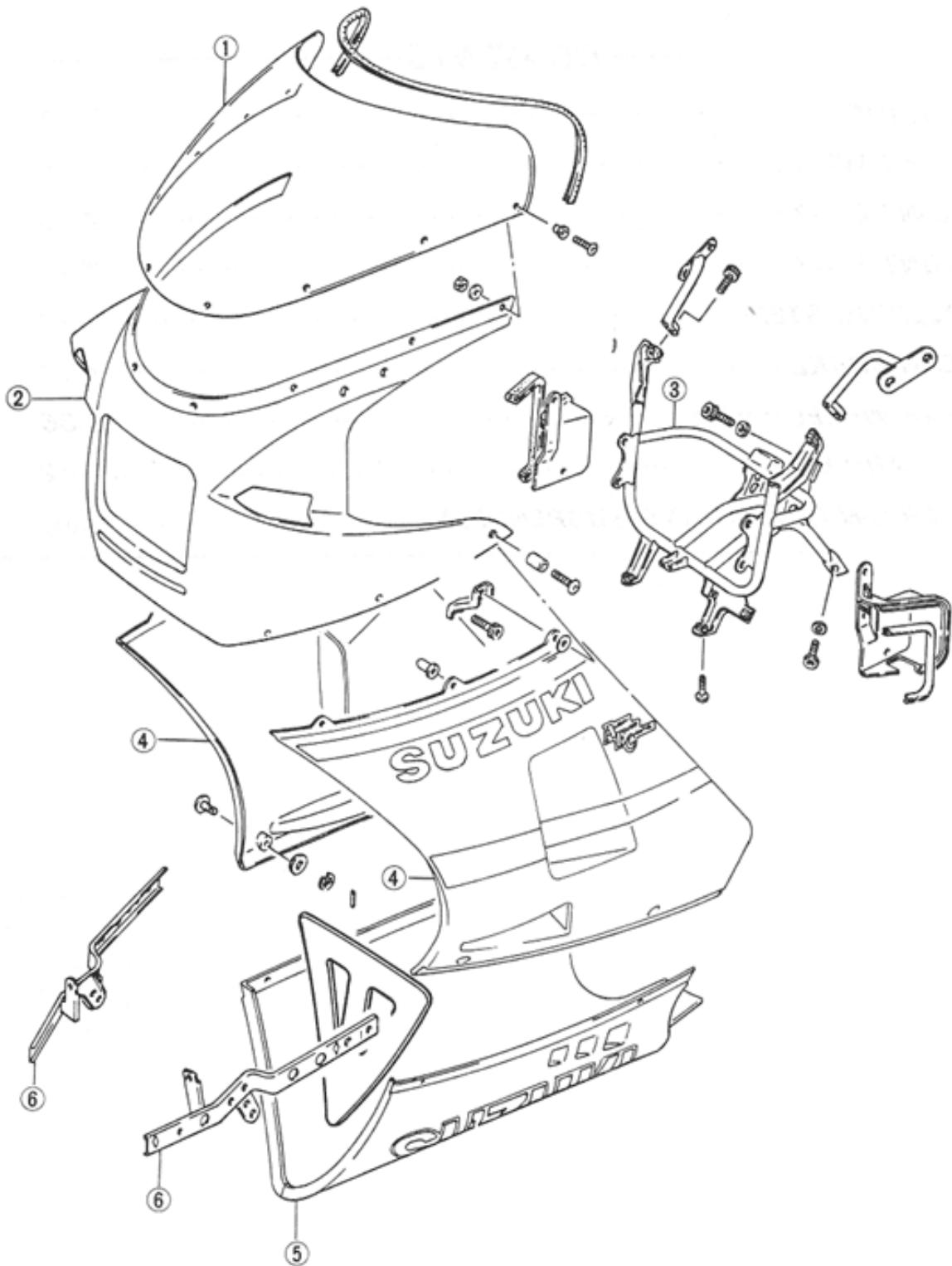

- ① Screen
- ② Upper fairing
- ③ Fairing brace
- ④ Middle fairing
- ⑤ Lower fairing
- ⑥ Lower fairing brace

**REMOVAL**

- Remove the middle fairings by loosening three screws ①, unfastening two screws ② and pulling out a plastic clip ③, right and left.

09900-00401

L-type hexagon wrench set

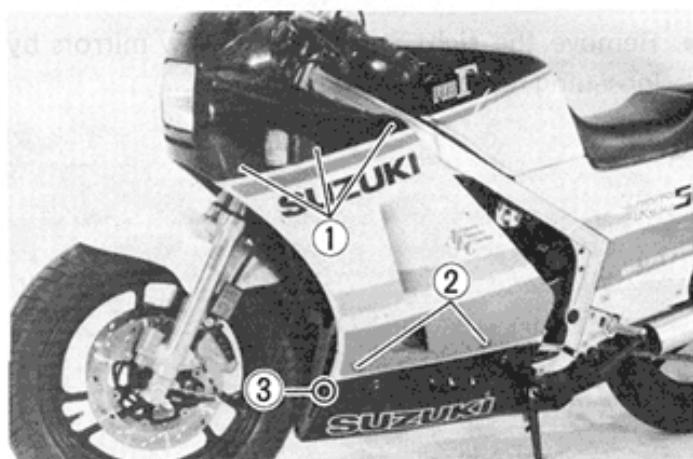

- Loosen the speedometer cable securing screw and pull out the cable.

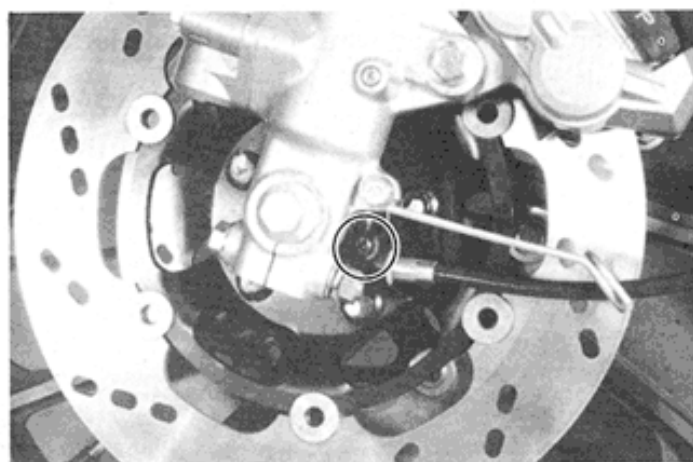

- For the left side middle fairing, pull out the speedometer cable from the cable guide.

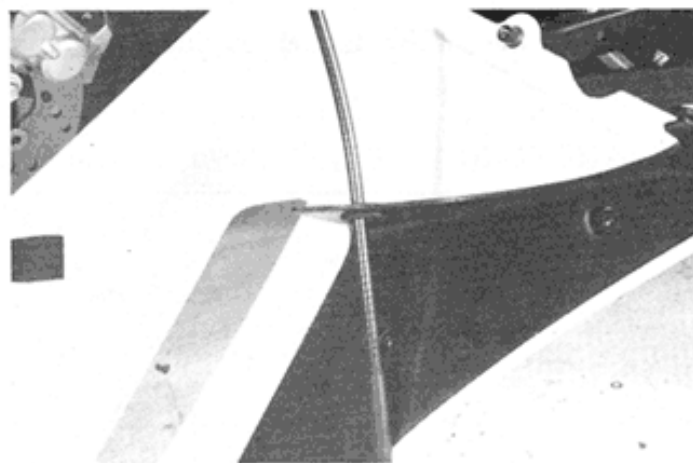

- Remove the lower fairing by loosening three screws, right and left.

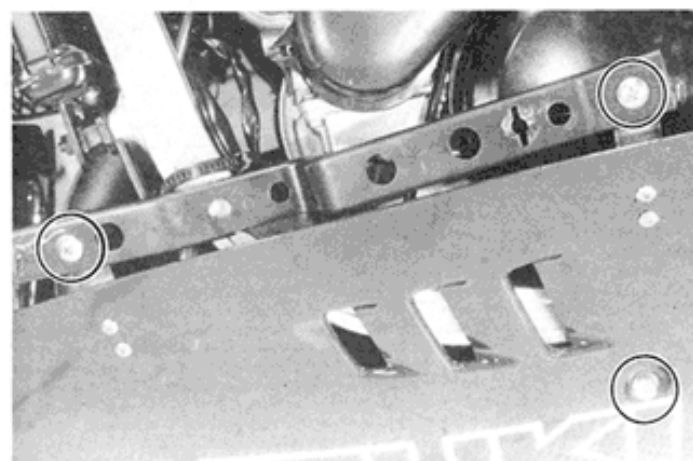

## 7-3 CHASSIS

- Remove the right and left rear view mirrors by loosening respective two nuts.

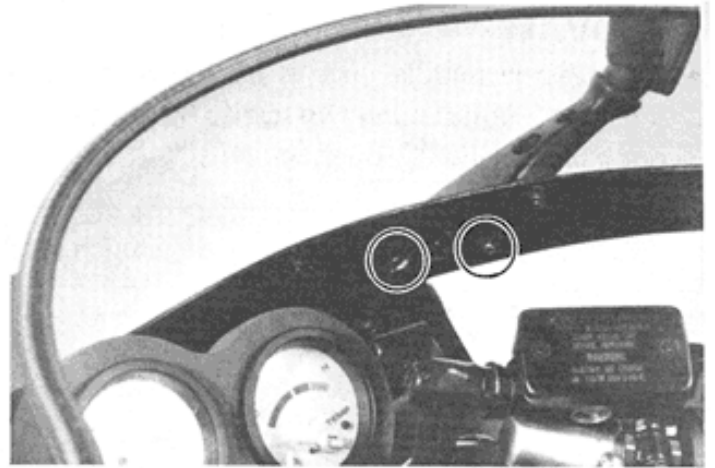

- Disconnect the lead wires for right and left turn signals.



- Remove the upper fairing by loosening two screws.

09900-00401

L-type hexagon wrench set

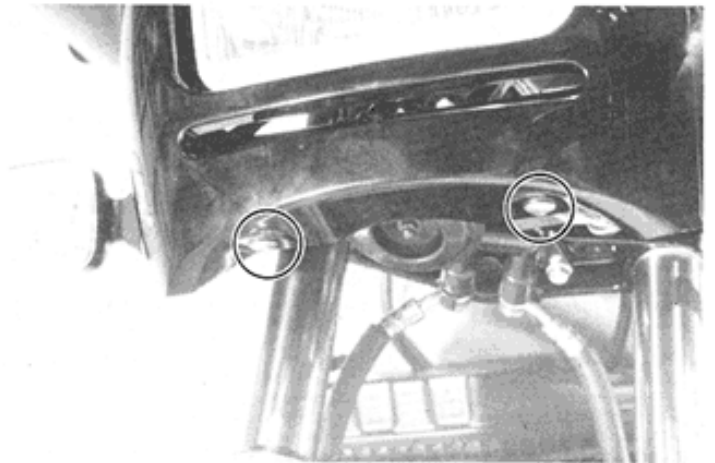

## FRONT WHEEL

## CONSTRUCTION

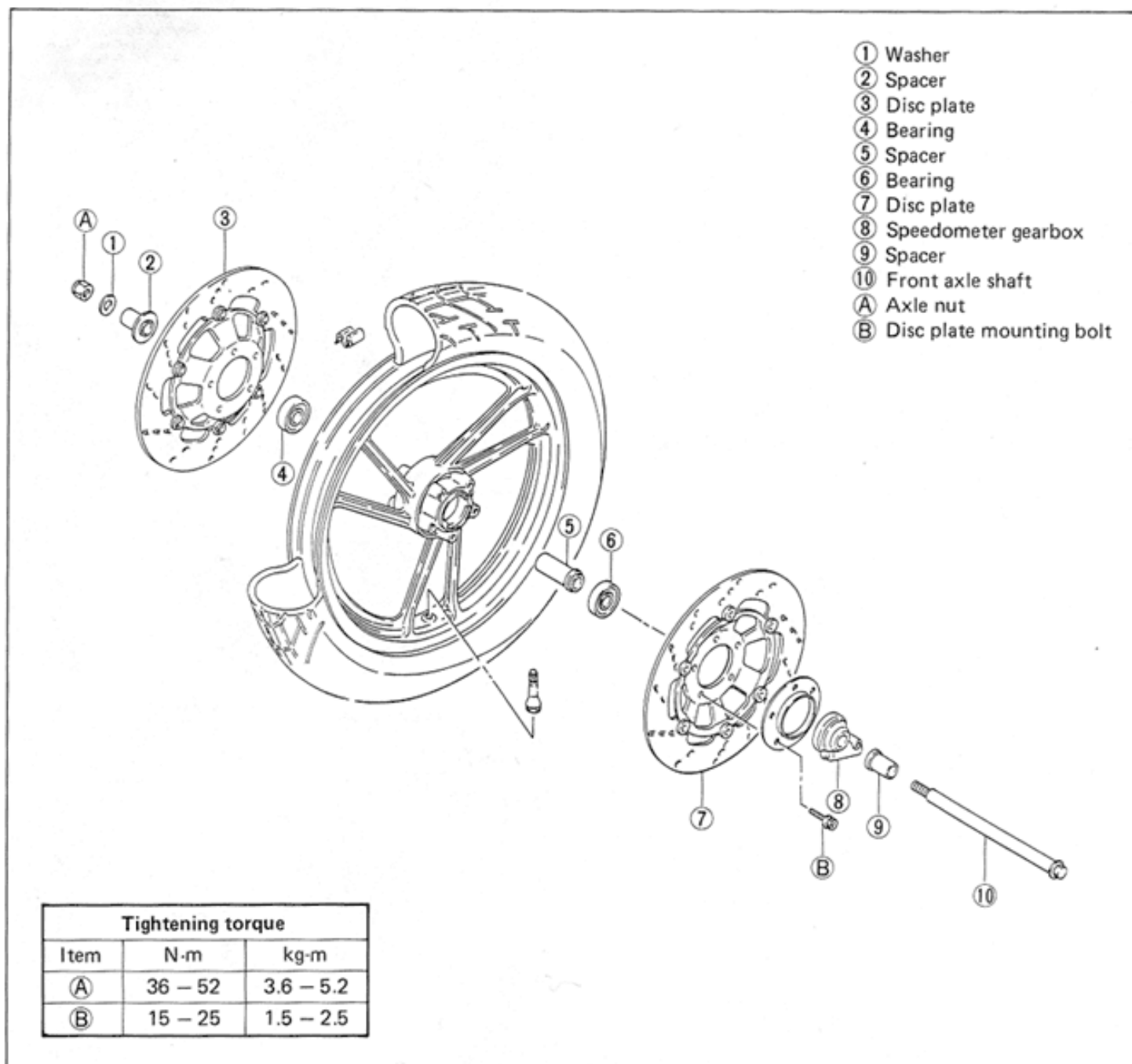

## REMOVAL AND DISASSEMBLY

- Remove the middle fairing and lower fairing. (Refer to page 7-1)
- Support the motorcycle by jack with wooden block.

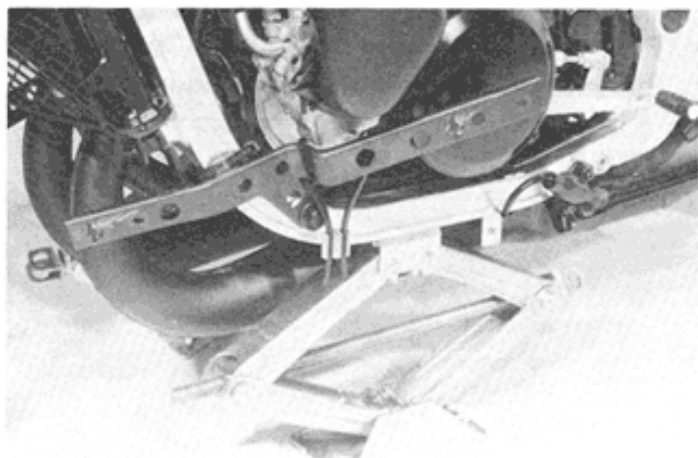

- Loosen the axle nut.

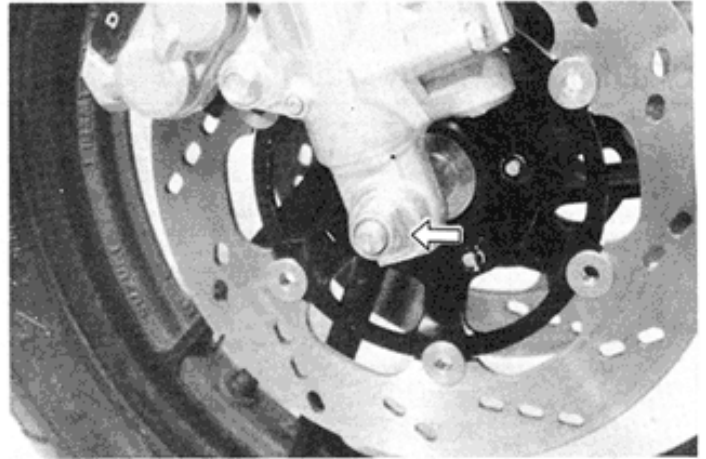

- Loosen the axle clamp nut.
- Remove the right and left calipers by loosening caliper mounting bolts.
- Draw out the axle shaft and take off the front wheel.

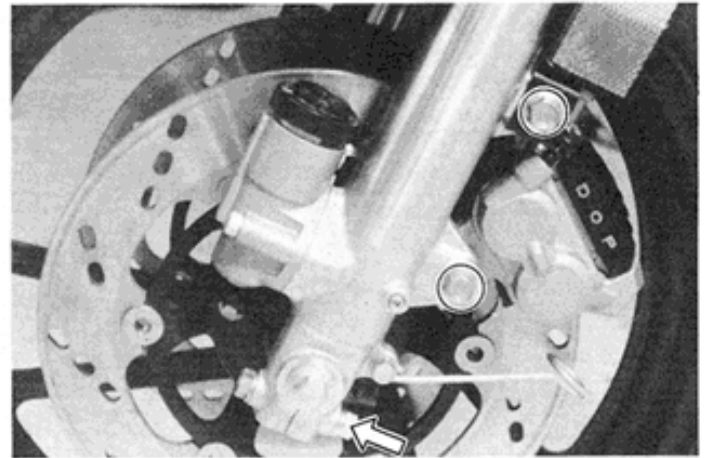

- Remove the securing bolts and separate the both discs from the wheel.

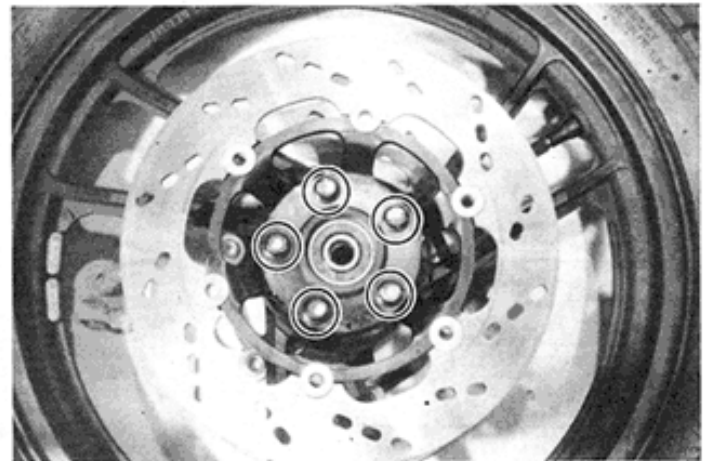

- Drive out the both wheel bearings by using the special tool in the following procedures.

09941-50110

Bearing remover

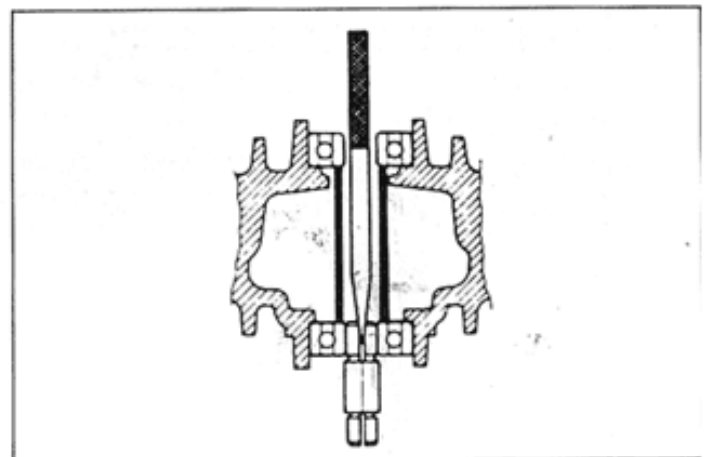

- Insert the adapter into the wheel bearing.
- After inserting the wedge bar from the opposite side, lock the wedge bar in the slit of the adapter.
- Drive out the wheel bearing by knocking the wedge bar.

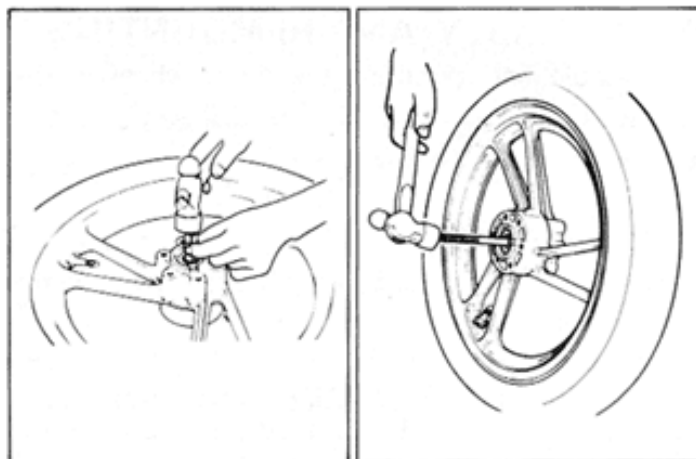

**CAUTION:**

The removed bearing should be replaced.

**INSPECTION**

**TIRE** ..... Refer to page 2-15

**WHEEL BEARINGS**

Inspect the play of the wheel bearings inner race by hand while fixing it in the wheel. Rotate the inner race by hand to inspect for abnormal noise and rotating smoothly. Replace the bearing if there is something unusual.

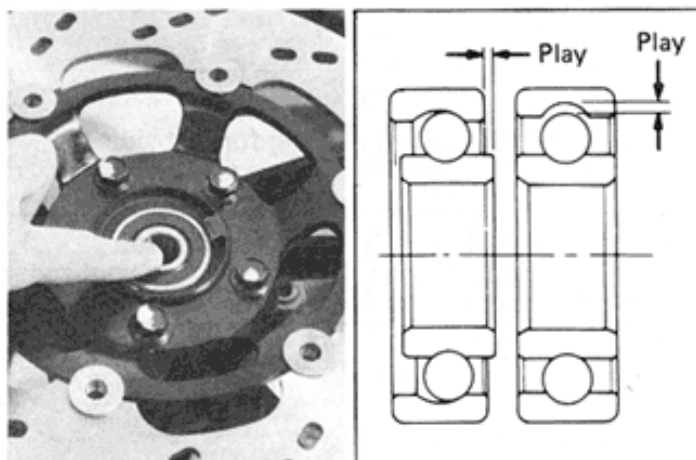

**AXLE SHAFT**

Using a dial gauge, check the axle shaft for runout and replace it if the runout exceeds the limit.

09900-20606	Dial gauge (1/100)
09900-20701	Magnetic stand
Service Limit	0.25 mm

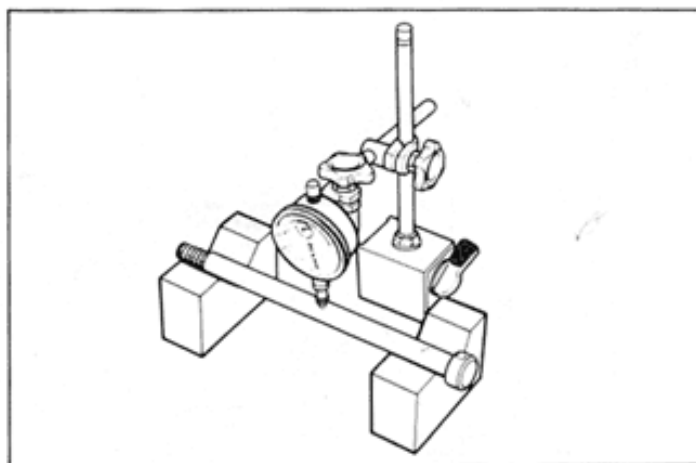

**WHEEL**

Make sure that the wheel runout checked as shown does not exceed the service limit. An excessive runout is usually due to worn or loose wheel bearings and can be reduced by replacing the bearings. If bearing replacement fails to reduce the runout, replace the wheel.

Service Limit (Axial and Radial)	2.0 mm
-------------------------------------	--------

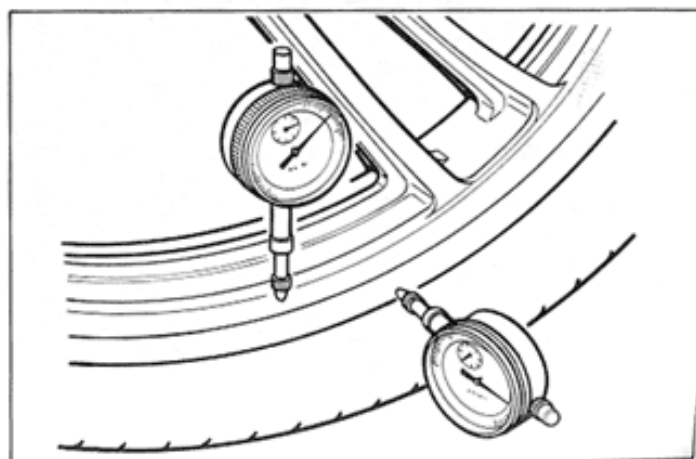

## REASSEMBLY AND REMOUNTING

Reassemble and remount the front wheel in the reverse order of removal and disassembly, and also carry out the following steps:

### WHEEL BEARING

- Apply grease to the bearing before installing the bearings.

99000-25010	SUZUKI super grease "A"
-------------	-------------------------

- Install the wheel bearings as follows by using the special tool.

**CAUTION:**  
First install the wheel bearing for left side.

09941-34511	Bearing installer set
09924-84510	Bearing installer set

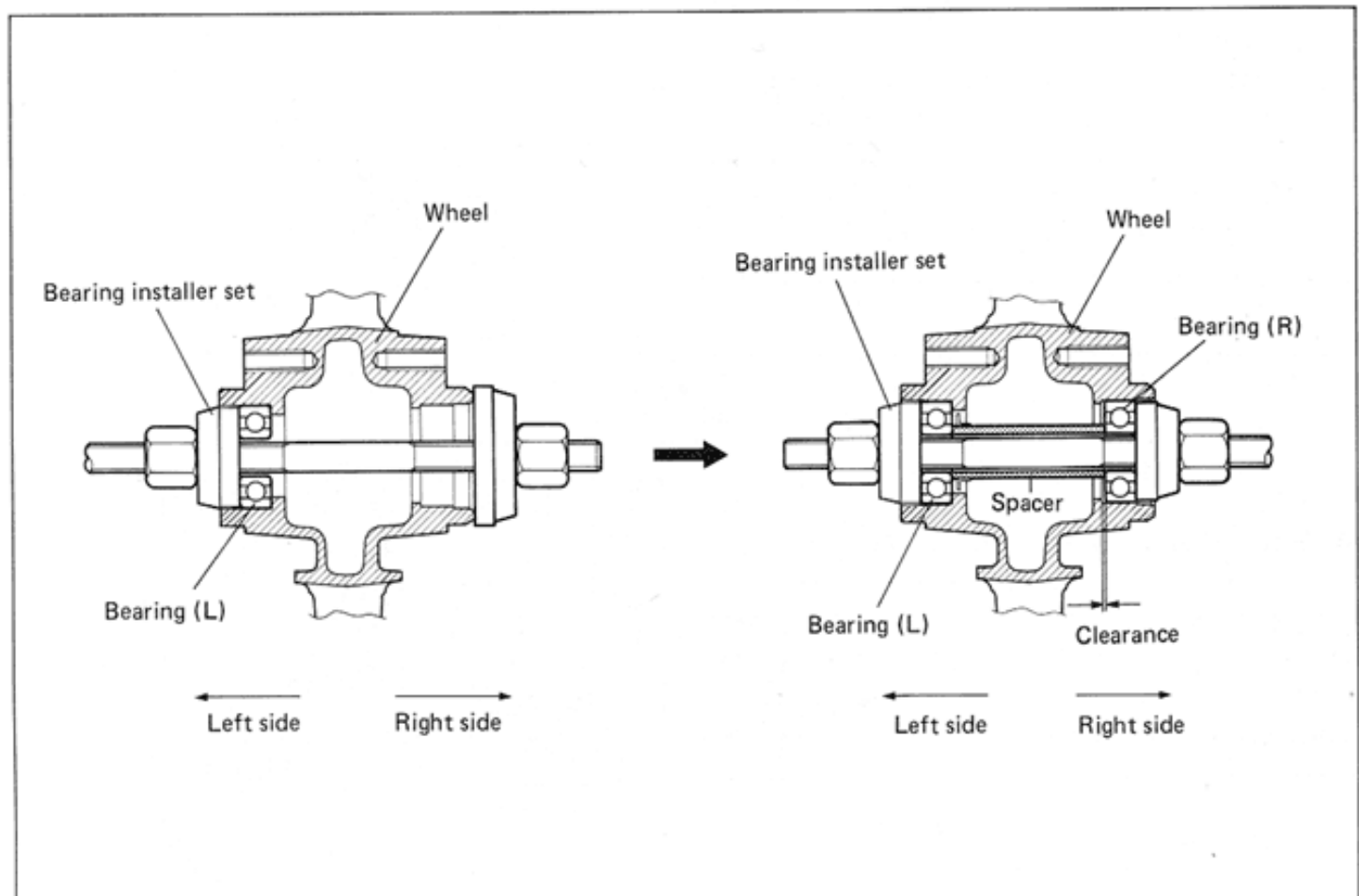
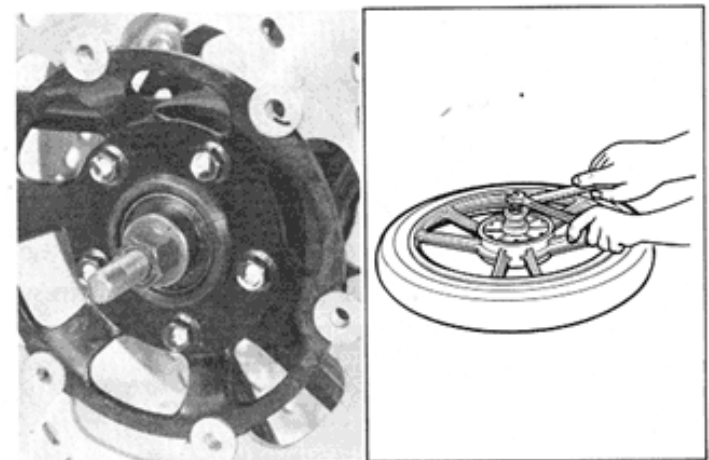
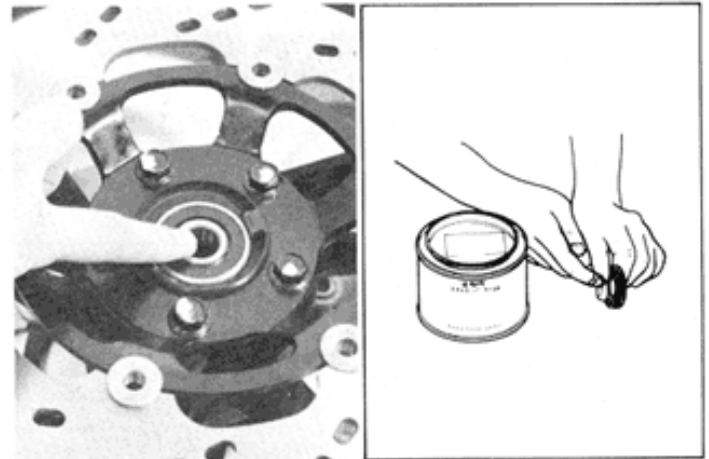

**DISC**

Make sure that brake disc is clean and free of any greasy matter. Apply Thread Lock "1360" and tighten to the specified torque.

Tightening torque	15 – 25 N·m (1.5 – 2.5 kg·m)
-------------------	---------------------------------

99000-32130	Thread Lock "1360"
-------------	--------------------

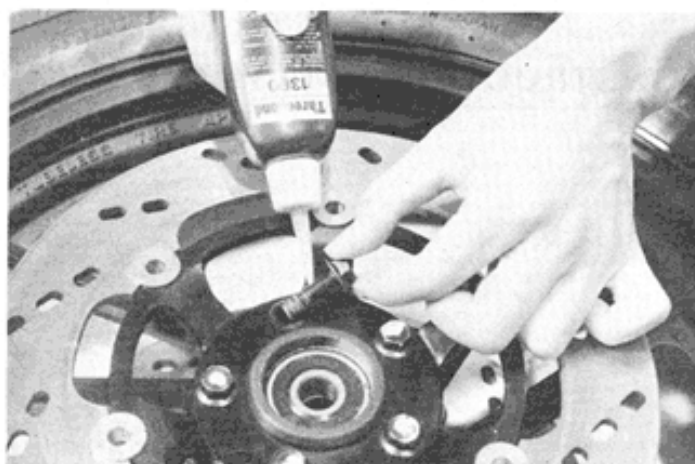
**SPEEDOMETER GEARBOX**

- Before installing the speedometer gearbox, grease it.
- When installing the speedometer gearbox to the wheel hub, be sure to align the groove between the two protrusions ① on the wheel hub with the two tabs ② of the speedometer gear.
- When tightening the front axle, check to be sure that the speedometer gearbox is in the position so that the speedometer cable does not bend sharply.

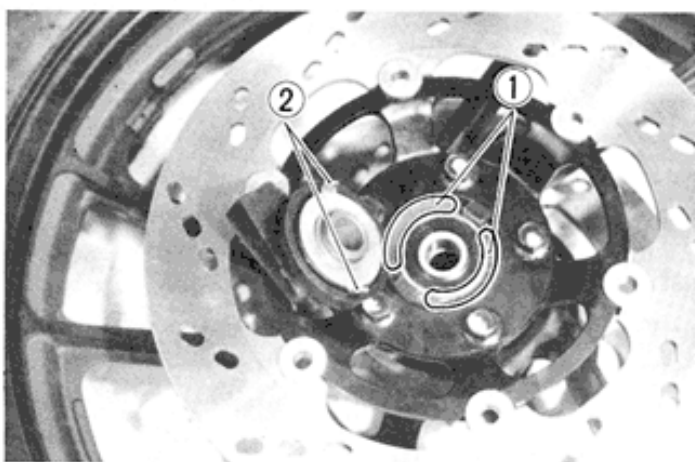
**AXLE SHAFT**

Insert the axle shaft from the left side and tighten the axle nut and axle shaft clamp nut to the specified torque.

Item	N·m	kg·m
Axle nut	36 – 52	3.6 – 5.2
Axle shaft clamp nut	15 – 25	1.5 – 2.5

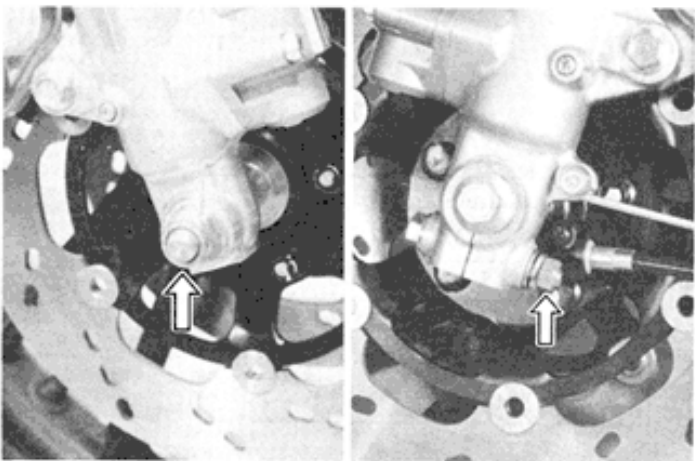
**NOTE:**

When tightening the axle nut, route the speedometer cable correctly.

**CALIPER**

Tighten the brake caliper mounting bolts to the specified torque.

Tightening torque	15 – 25 N·m (1.5 – 2.5 kg·m)
-------------------	---------------------------------

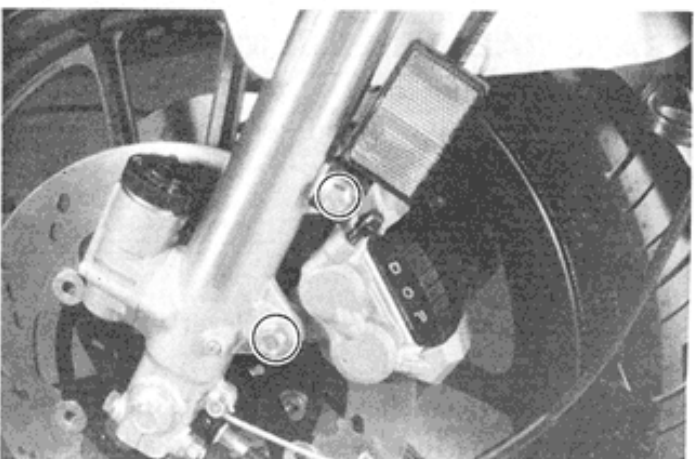
**NOTE:**

Push the pistons all the way into the caliper and remount the calipers.

## FRONT BRAKE

## CONSTRUCTION (MASTER CYLINDER AND CALIPER)

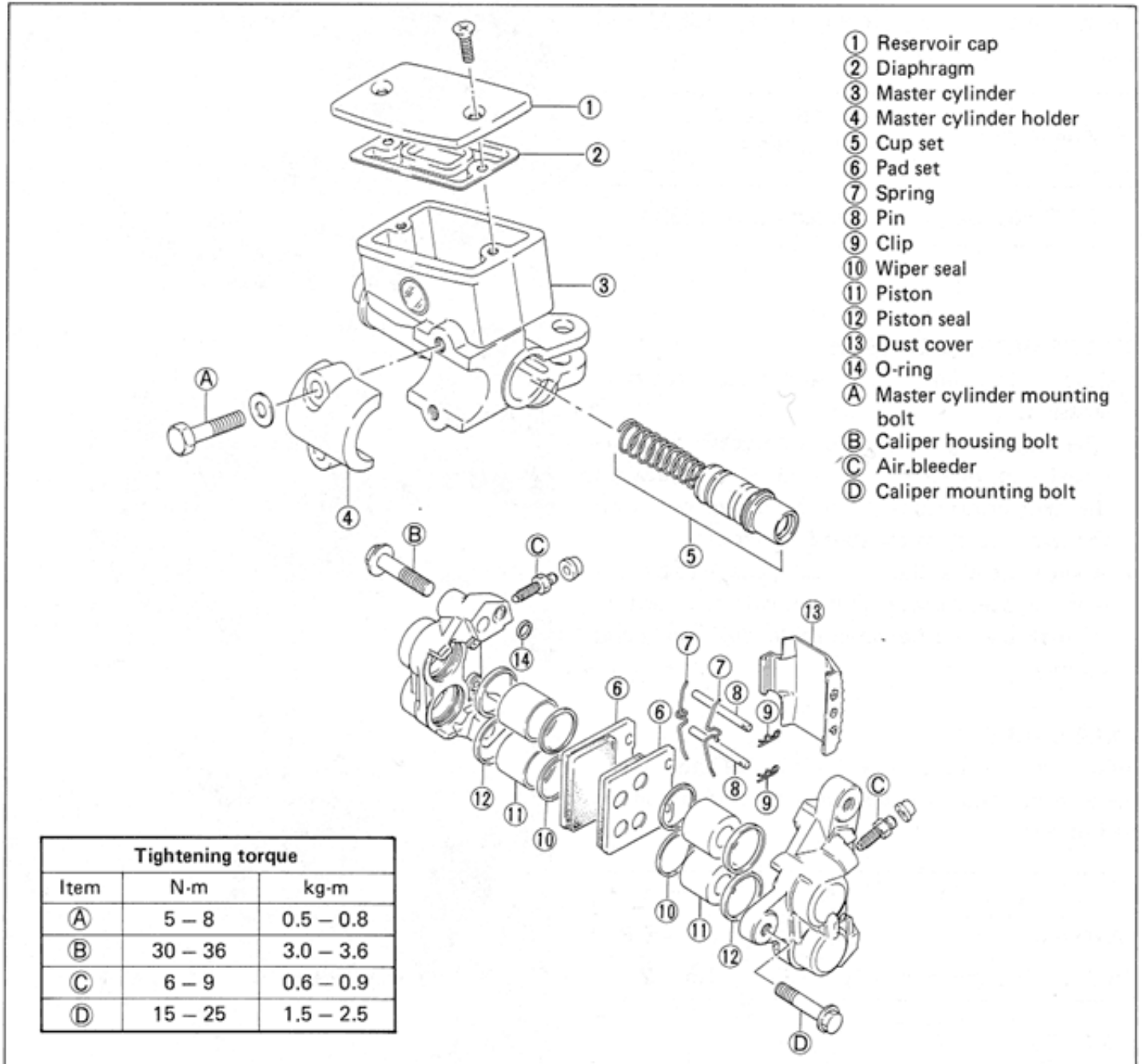

## BRAKE PAD REPLACEMENT

- Remove the dust cover.
- Remove the clips ① and springs ②, and draw out the pins ③.
- Take off the pads.

## CAUTION:

- \* Do not operate the brake lever while dismounting the pads.
- \* Replace the brake pad as a set, otherwise braking performance will be adversely affected.

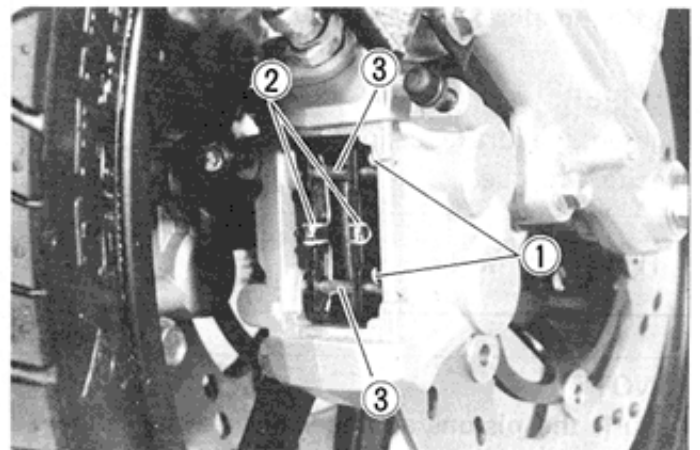

## CALIPER REMOVAL AND DISASSEMBLY

- Remove the reflector by loosening the upper side caliper mounting bolt. (Only for E-28 and E-39)
- Loosen the nut ② while holding the lock nut ①.
- Disconnect the brake hose and catch the brake fluid in a suitable receptacle.

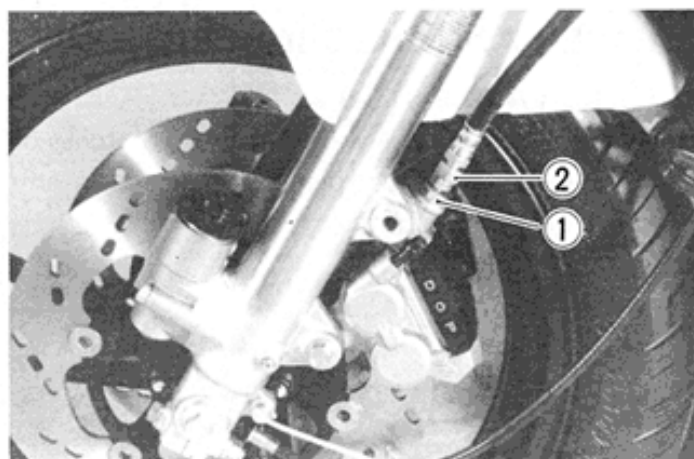
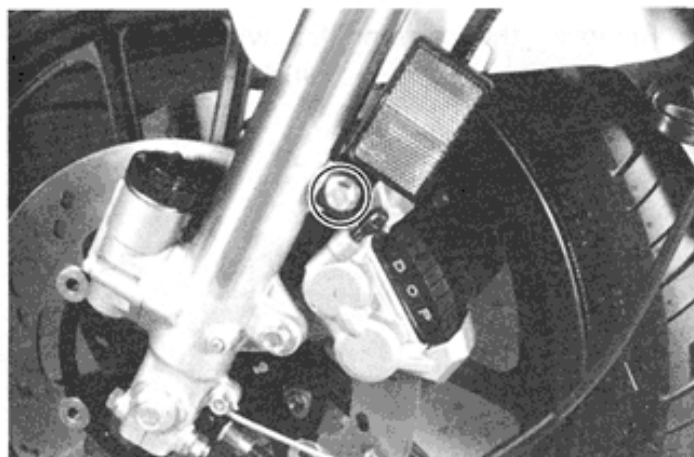

### WARNING:

Brake fluid, if it leaks, will interfere with safe running and discolor painted surfaces. Check the brake hose for cracks and hose joint for leakage before riding.

- Remove the lower side caliper mounting bolt and take off the caliper. (Only for E-28 and E-39)
- Remove the two caliper mounting bolts and take off the caliper. (For the others)

### NOTE:

Slightly loosen the caliper housing bolts to facilitate later disassembly before removing the caliper mounting bolts.

- Remove the pads. (Refer to page 7-9)
- Separate the caliper by removing the caliper housing bolts.
- Remove the O-rings ③.

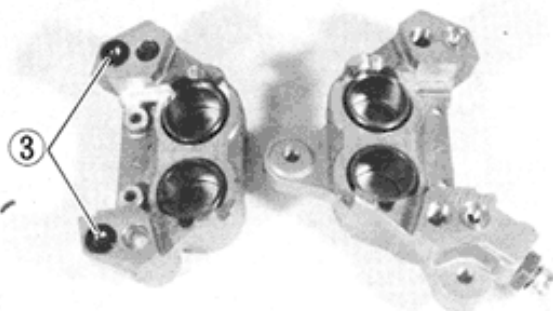

### NOTE:

Once separate the caliper halves, replace the O-ring ③ with a new one.

- Push out the piston by using an air gun.

### CAUTION:

Do not use high pressure air to prevent piston damage.

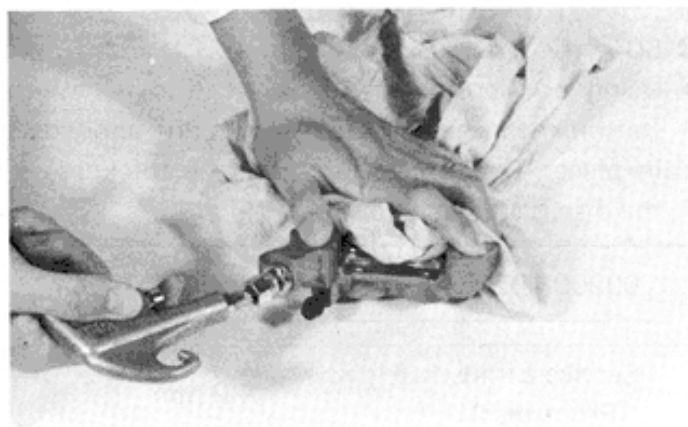

- Remove the pistons ①, wiper seals ② and piston seals ③ from the caliper.

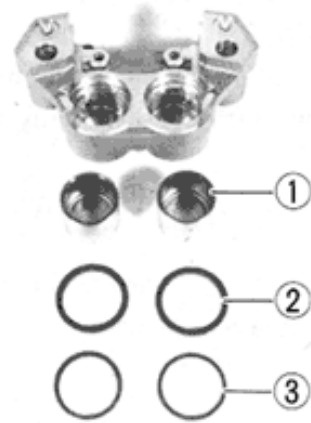

### CALIPER AND DISC INSPECTION - CYLINDER AND PISTON

Inspect the caliper bore wall for nicks, scratches or other damage and the piston surface for any scratches or other damage.

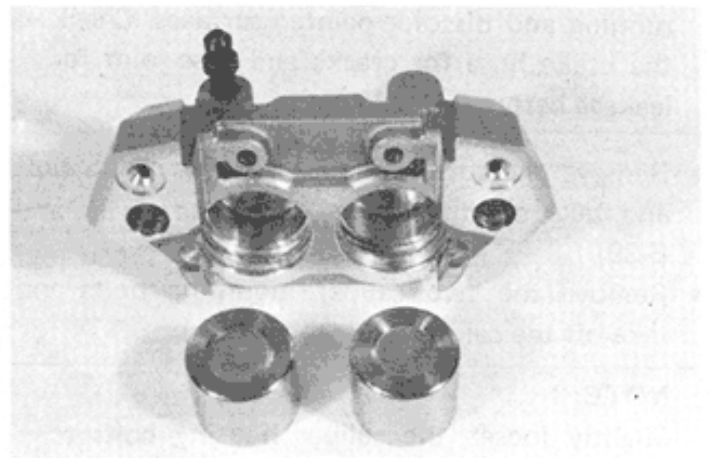

### RUBBER PART

Inspect each rubber parts for damage and wear.

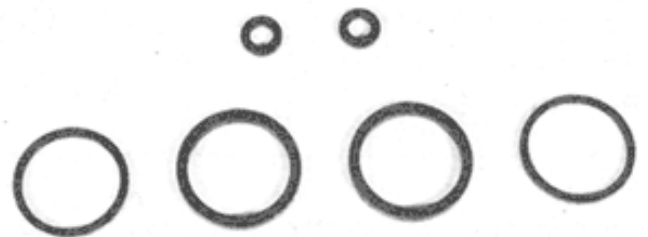

### DISC

- Using a micrometer check the disc for wear. Its thickness can be checked with disc and wheel in place. The service limit for the thickness of the disc is shown below.

09900-20205	Micrometer (0 – 25 mm)
-------------	------------------------

Service Limit (Front disc)	4.0 mm
----------------------------	--------

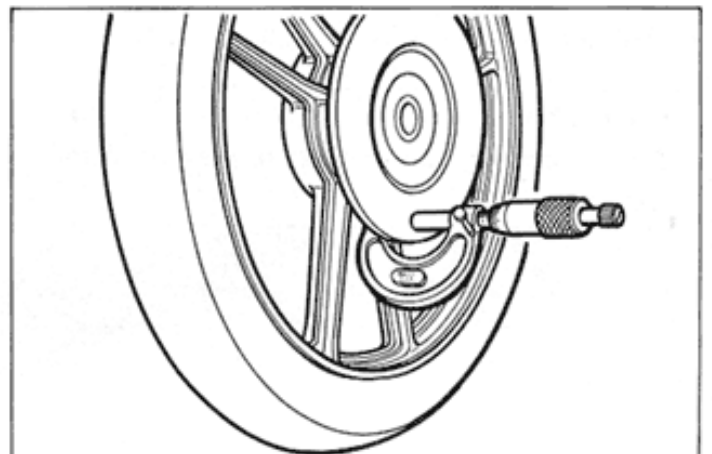

- With the disc mounted on the wheel, check the disc for face runout with a dial gauge, as shown.

09900-20606	Dial gauge (1/100 mm)
09900-20701	Magnetic stand
Service Limit	0.30 mm

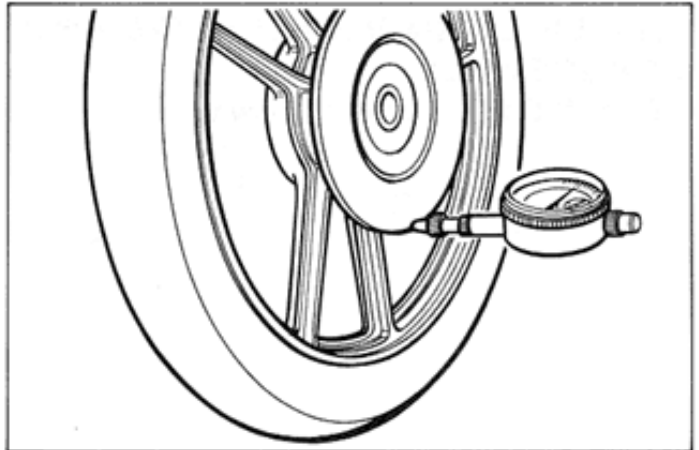

## CALIPER REASSEMBLY AND REMOUNTING

Reassemble and remount the caliper in the reverse orders of removal and disassembly and carry out the following steps.

### CAUTION:

- \* Wash the caliper components with fresh brake fluid before reassembly.
- \* Never use cleaning solvent or gasoline to wash them.
- \* Apply brake fluid to the caliper bore and piston to be inserted into the bore.

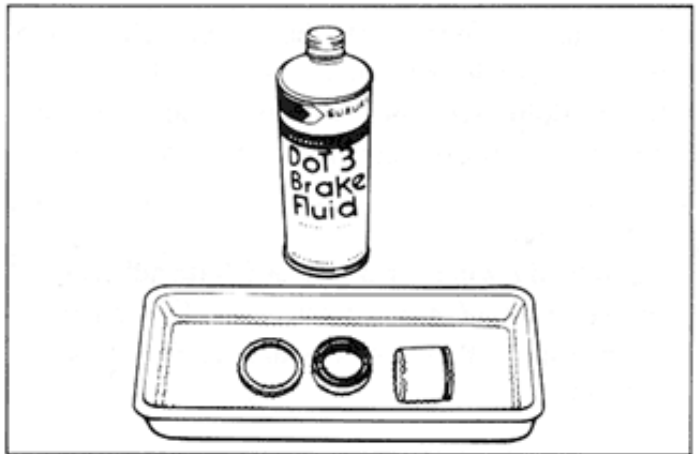

## CALIPER BOLTS

Tighten the bolts to the specified torque.

Item	N·m	kg·m
Union bolt	20 – 25	2.0 – 2.5
Caliper mounting bolt	15 – 25	1.5 – 2.5
Caliper housing bolt	30 – 36	3.0 – 3.6

### CAUTION:

Bleed the air after reassembling the caliper.  
(Refer to page 2-14)

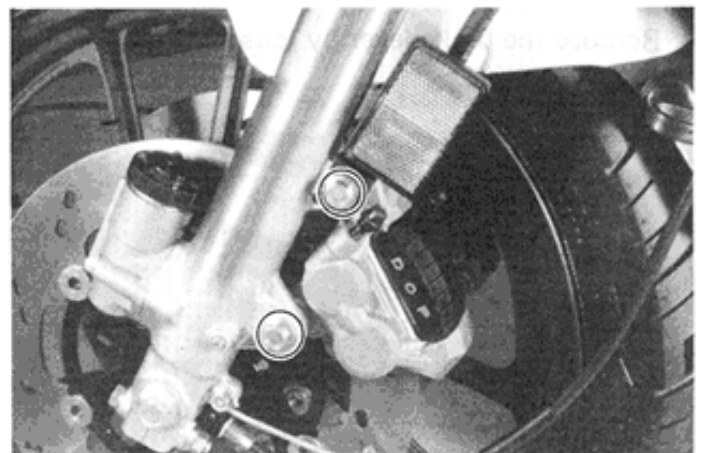
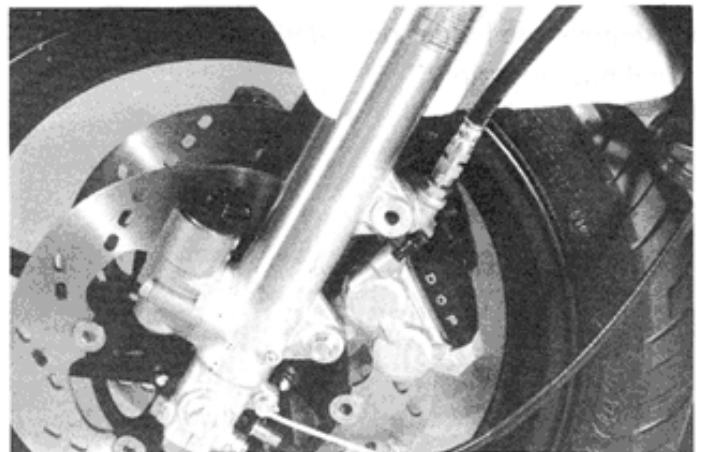

## MASTER CYLINDER REMOVAL AND DISASSEMBLY

- Take off the front brake light switch.

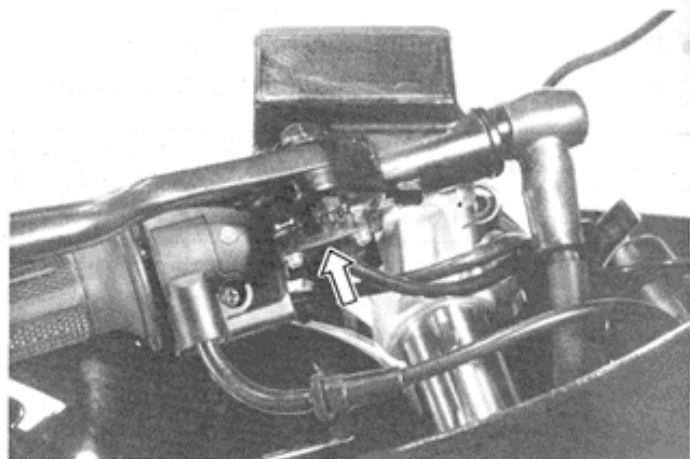

- Place a rag underneath the union bolt on the master cylinder to catch the spilled drops of brake fluid. Unscrew the union bolt and disconnect the brake hose/master cylinder joint.

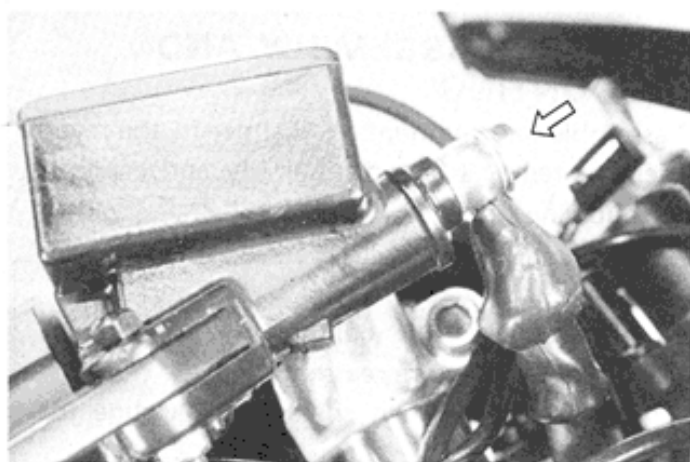

### CAUTION:

Completely wipe off any brake fluid adhering to any part of motorcycle. The fluid reacts chemically with paint, plastics, rubber materials, etc.

- Remove the holder bolts and take off the master cylinder assembly.

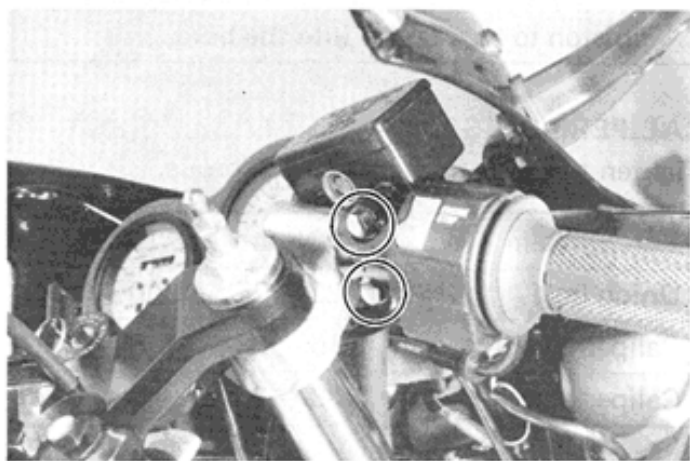

- Remove the brake lever by loosening a bolt.

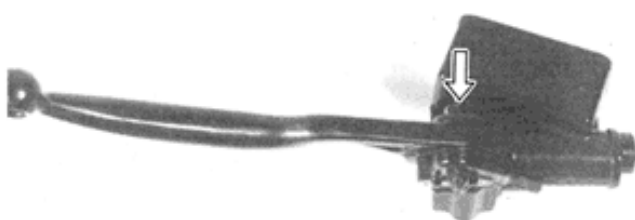

- Remove the reservoir cap and diaphragm by loosening two screws.
- Drain brake fluid.

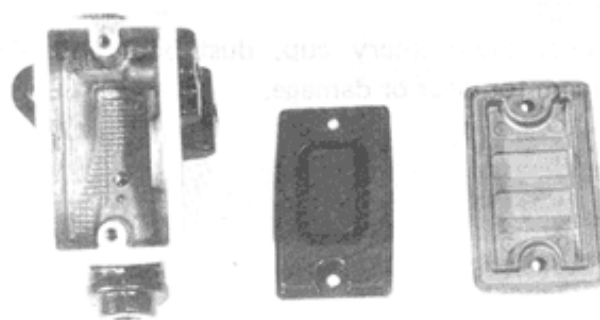

- Pull out the dust boot ① and then remove the circlip ② by using a special tool.

09900-06108	Snap ring pliers
-------------	------------------

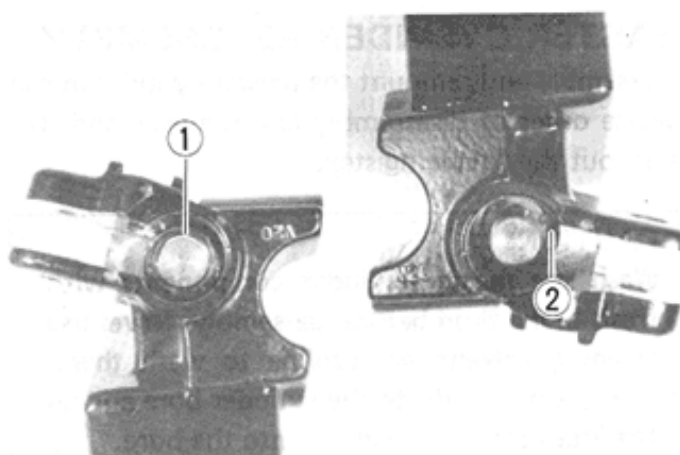

- Remove the piston, primary cup and return spring.

- ① Circlip
- ② Piston
- ③ Primary cup
- ④ Return spring

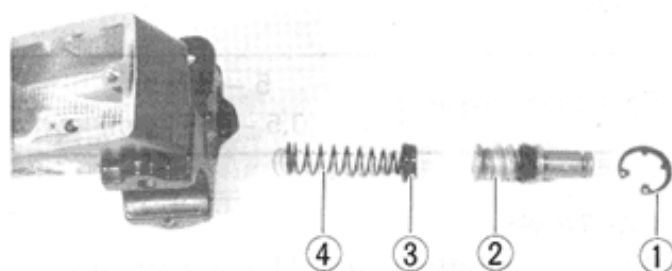

### MASTER CYLINDER INSPECTION

- Inspect the master cylinder bore for any scratches or other damage.

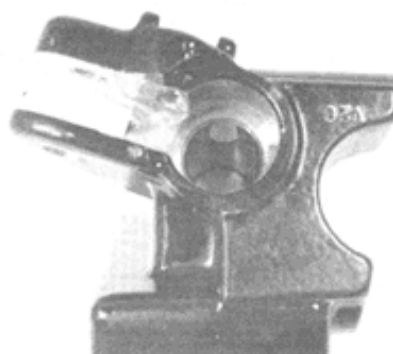

- Inspect the piston surface for scratches or other damage.
- Inspect the primary cup, dust boot and diaphragm for wear or damage.

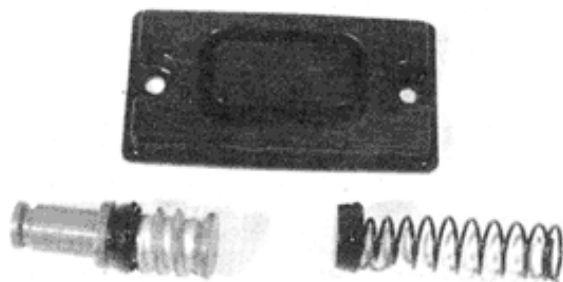

### MASTER CYLINDER REASSEMBLY

Reassemble and remount the master cylinder in the reverse order of disassembly and removal, and also carry out the following steps:

**CAUTION:**

Wash the master cylinder components with fresh brake fluid before reassembly. Never use cleaning solvent or gasoline to wash them. Apply brake fluid to the cylinder bore and all the internals to be inserted into the bore.

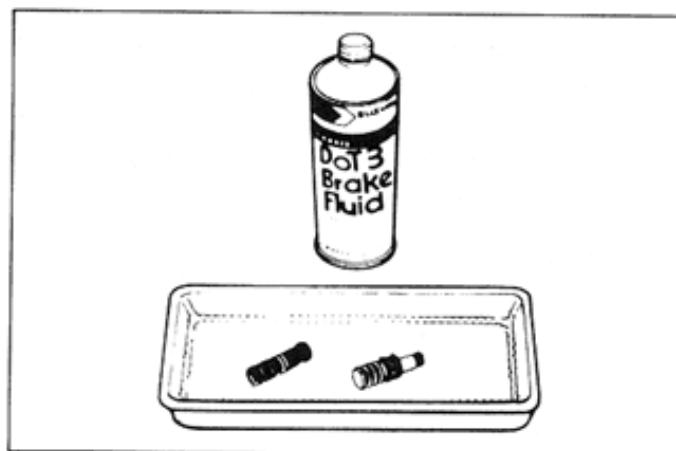

When remounting the master cylinder on the handlebars, first tighten the clamp bolt for upside as shown.

Tightening torque	5 – 8 N·m (0.5 – 0.8 kg-m)
-------------------	-------------------------------

**CAUTION:**

Bleed the air after reassembling master cylinder (See page 2-14).

Adjust the front brake light switch after installation.

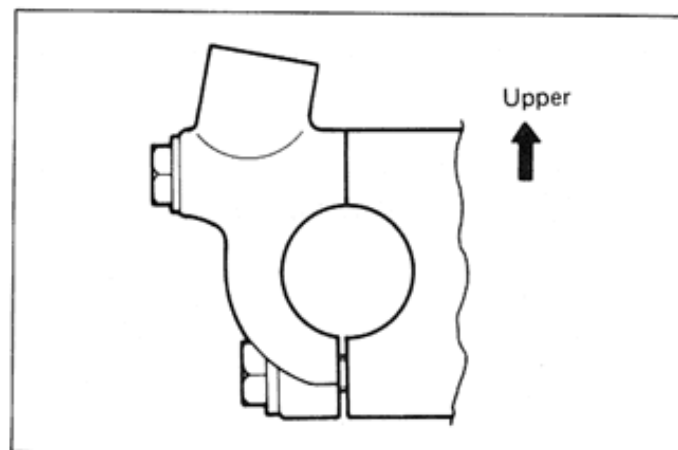

## FRONT FORK

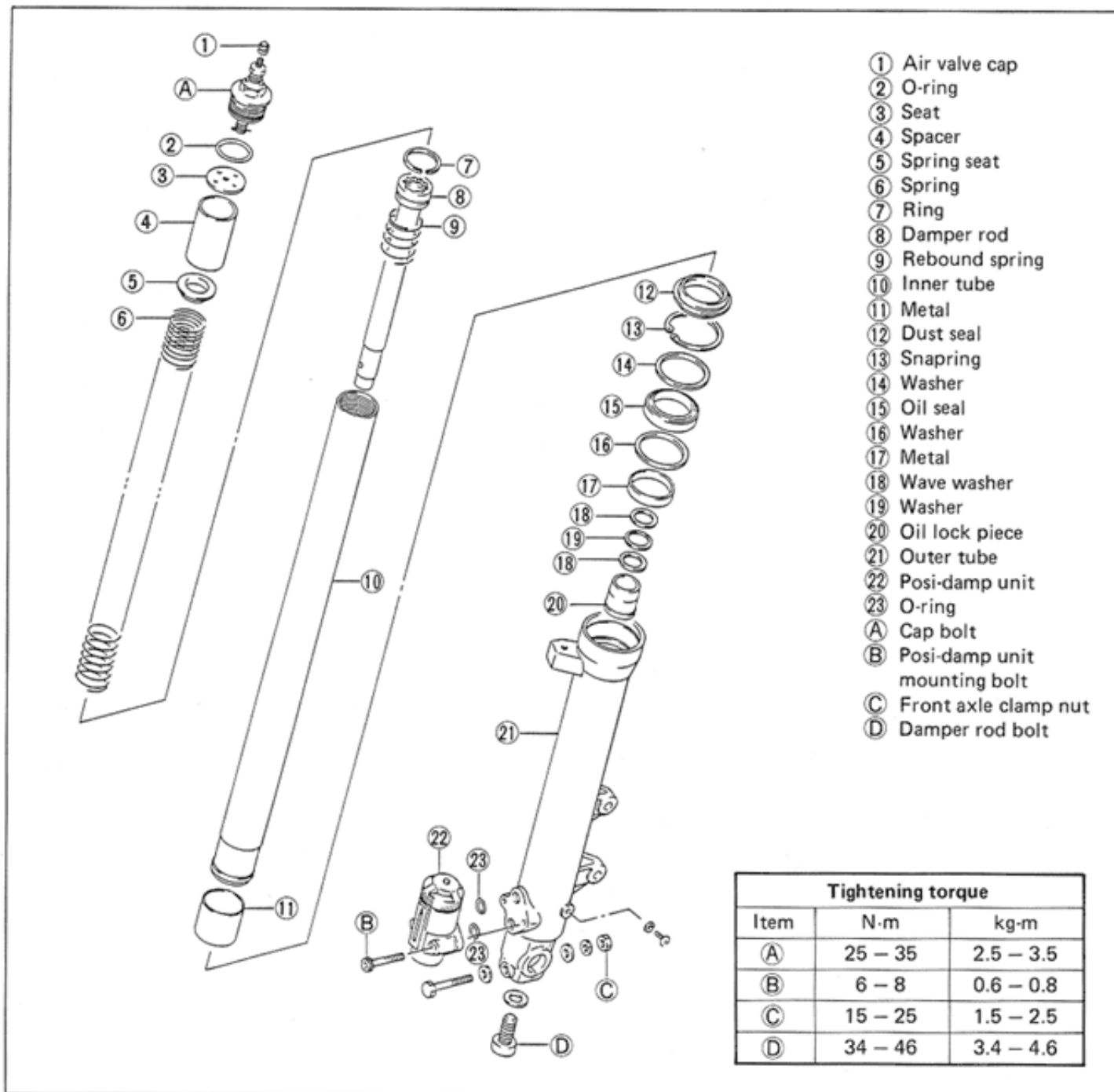

## REMOVAL AND DISASSEMBLY

- Remove the fairing. (Refer to page 7-1)
- Remove the front wheel. (Refer to page 7-4)
- Remove the stabilizer and front fender by loosening eight allen screws.

09900-00401

L-type hexagon wrench set

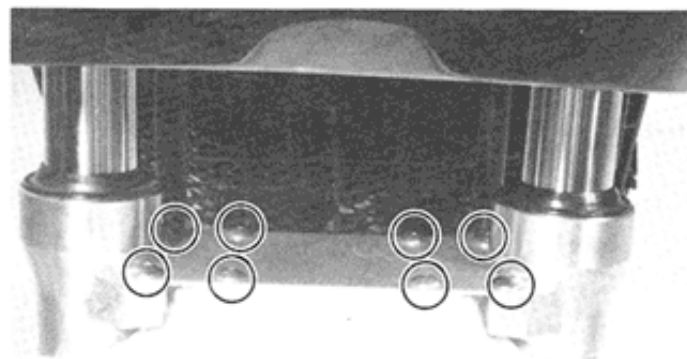

- Remove the circlip of the handlebar set bolt.

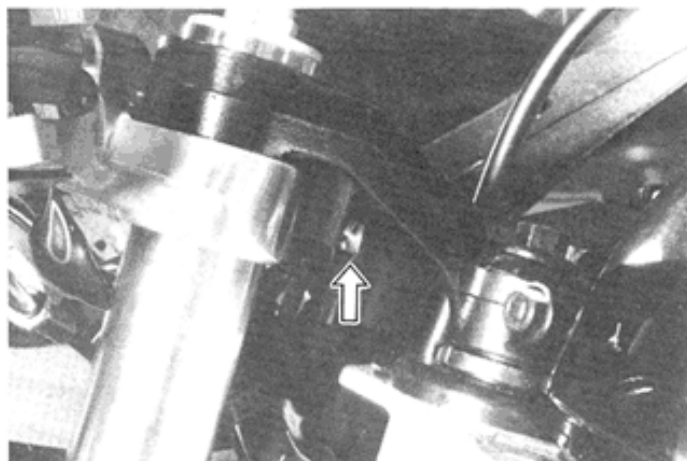

- Loosen the handlebar clamp bolt and shift the handlebar inwards.

09900-00401	L-type hexagon wrench set
-------------	---------------------------

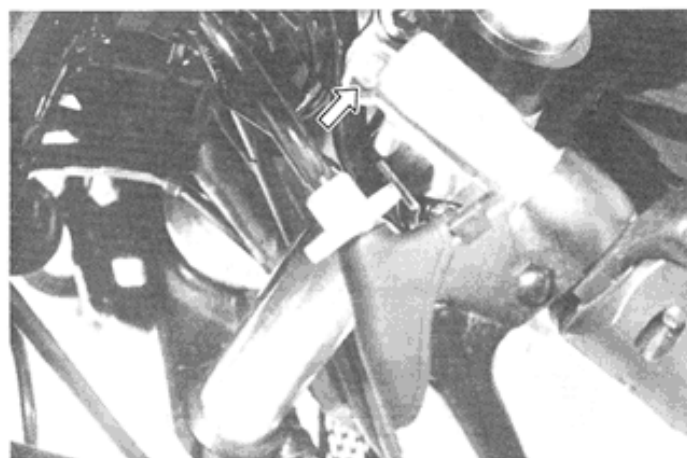

- Slightly loosen the front fork cap bolt to facilitate later disassembly.
- Loosen the front fork upper and lower clamp bolts and pull down the front fork assembly.

09900-00401	L-type hexagon wrench set
-------------	---------------------------



- Remove the front fork cap bolt ① and draw out the seat ②, spacer ③, spring seat ④ and spring ⑤.

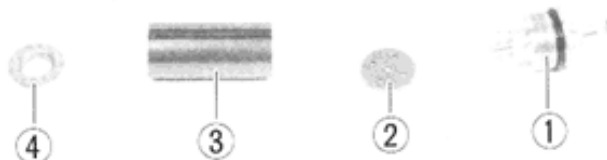
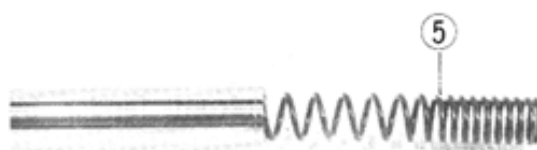

- Invert the fork and stroke it several times to remove the oil.
- Hold the fork inverted for a few minutes to drain the oil.

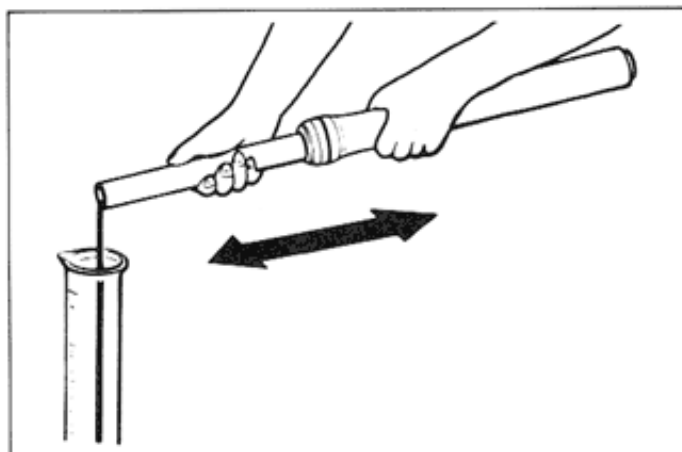

- Remove the damper rod securing bolt by using the special tools.

①	09940-34520	"T" handle
②	09940-34581	Attachment "F"
③	09900-00401	L-type hexagon wrench set

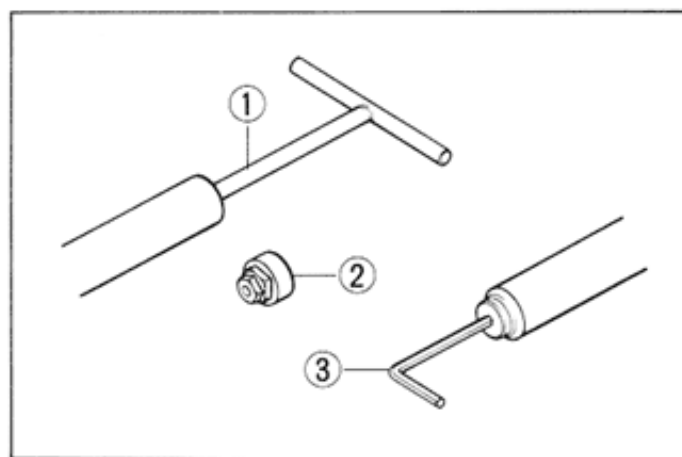

- Remove the dust seal.



- Remove the snap ring by using the special tool.

09900-06108	Snap ring pliers
-------------	------------------

- Draw out the damper rod and rebound spring.

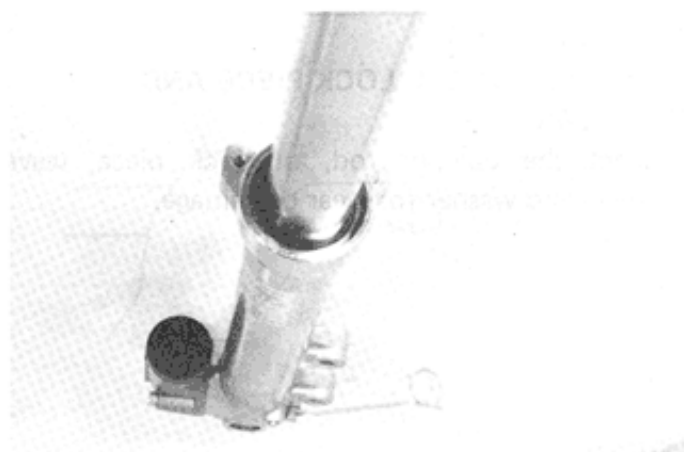

- While holding the caliper mounting portion by vise, separate the inner tube from the outer tube.

**CAUTION:**

The outer tube and inner tube "anti-friction" metals must be replaced along with the oil seal any time the fork is disassembled.

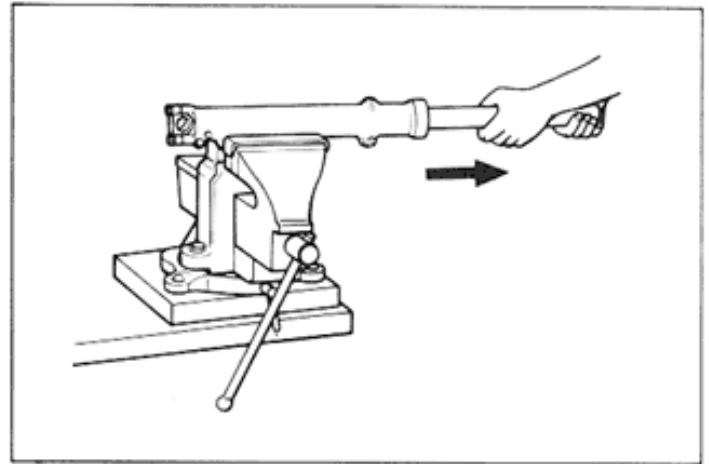

- Remove the two wave washers ①, washer ② and oil lock piece ③.

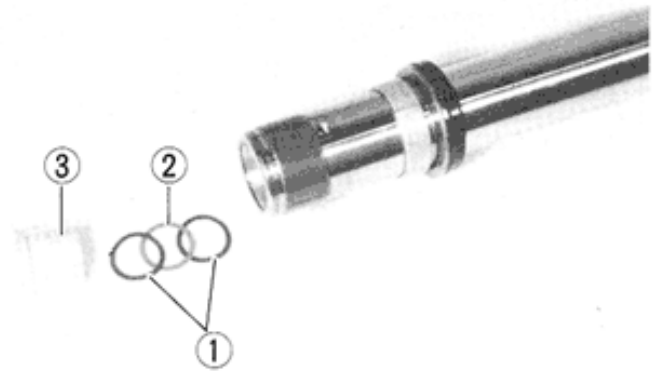

- Remove the posi-damp unit by loosening two bolts.

09900-00401	L-type hexagon wrench set
-------------	---------------------------

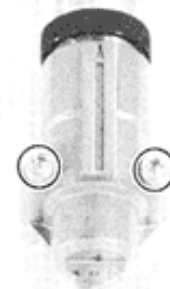

**INSPECTION  
DAMPER ROD, OIL LOCK PIECE AND  
WASHERS**

Inspect the damper rod, oil lock piece, wave washers and washer for wear or damage.



**INNER AND OUTER TUBES**

Inspect the inner tube outer surface and outer tube inner surface for any scuffing.

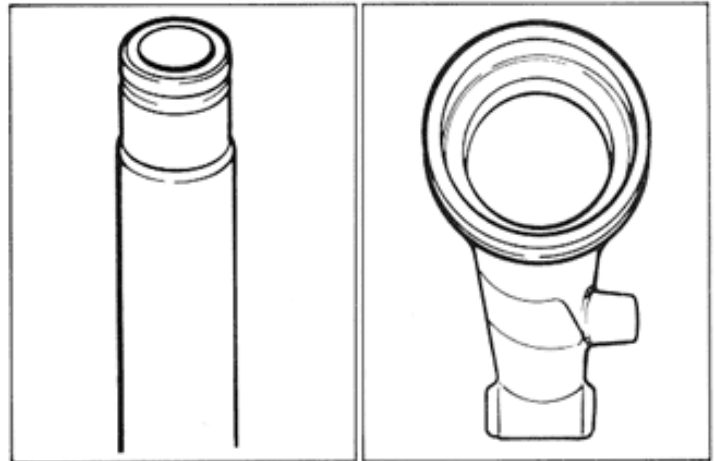
**FORK SPRING**

Measure the fork spring free length. If it is shorter than the service limit, replace it with a new one.

Service Limit	417 mm
---------------	--------

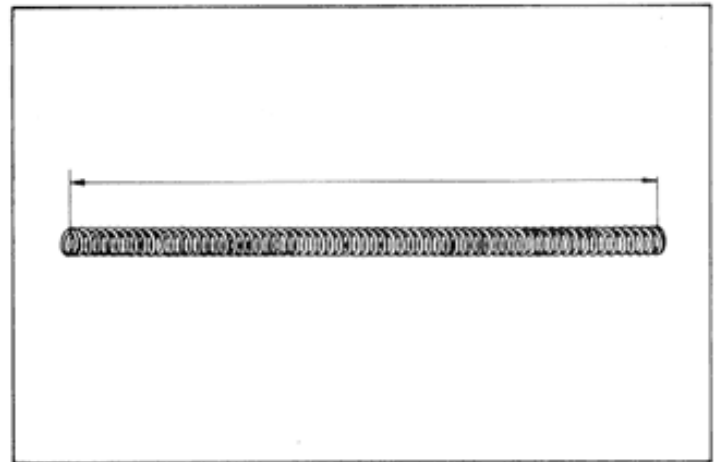
**POSI-DAMP UNIT**

After separating the posi-damp unit from the outer tube, inspect the unit for leakage of fork oil. If any defect is found, replace affected unit with a new one.

**NOTE:**

This unit is only available as a replacement unit.

Inspect the O-rings located between unit and front fork for wear or damage.

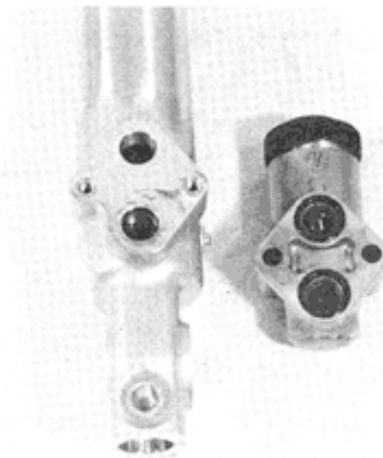
**REASSEMBLY AND REMOUNTING**

Reassemble and remount the front fork in the reverse order of removal and disassembly, and also carry out the following steps.

**INNER TUBE METAL**

Install the metal by hand as shown.

**CAUTION:**

Use special care to prevent damage to the "Teflon" coated surface of the Anti-friction metal when mounting it.

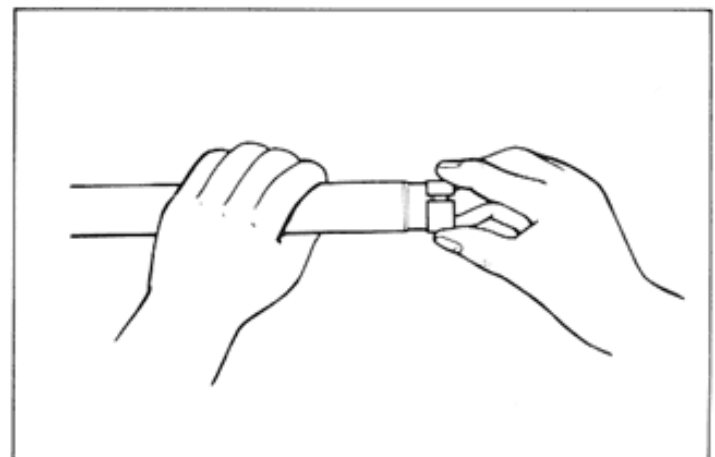

**OIL LOCK PIECE AND WASHERS**

Install the oil lock piece ①, washer ② and wave washers ③ as shown in the photograph.

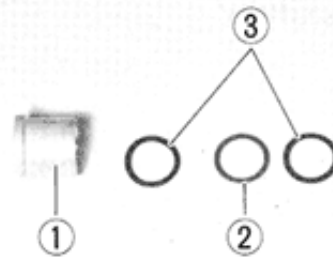

**DAMPER ROD BOLT**

Apply Thread Lock "1342" to the damper rod bolt and tighten to the specified torque.

99000-32050	Thread Lock "1342"
-------------	--------------------

Tightening torque	34 – 46 N·m (3.4 – 4.6 kg-m)
-------------------	---------------------------------

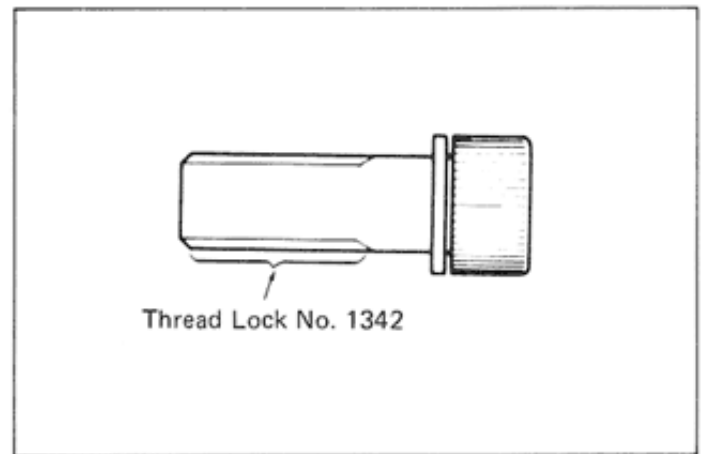

**OUTER TUBE METAL, WASHER AND OIL SEAL**

Install the outer tube metal, washer and oil seal by using the special tool.

**CAUTION:**  
Use special care to prevent damage to the "Teflon" coated surface of the anti-friction metal when mounting it.

09940-50112	Front fork oil seal installer
-------------	-------------------------------

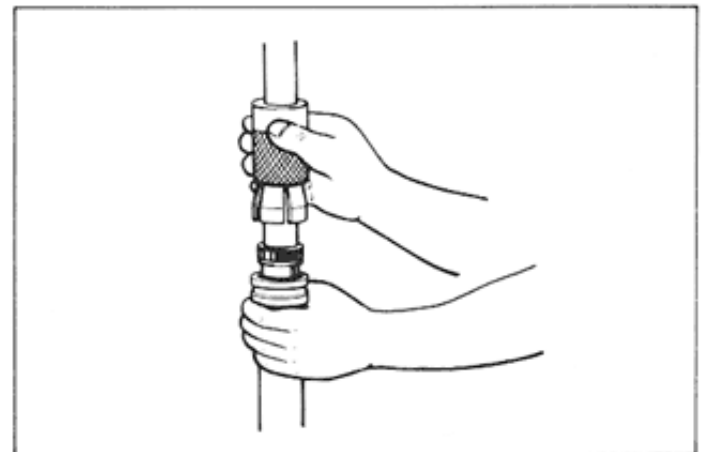

**POSI-DAMP UNIT**

Apply Thread Lock "1342" to the bolts and tighten them to the specified torque.

99000-32050	Thread Lock "1342"
-------------	--------------------

Tightening torque	6 – 8 N·m (0.6 – 0.8 kg-m)
-------------------	-------------------------------

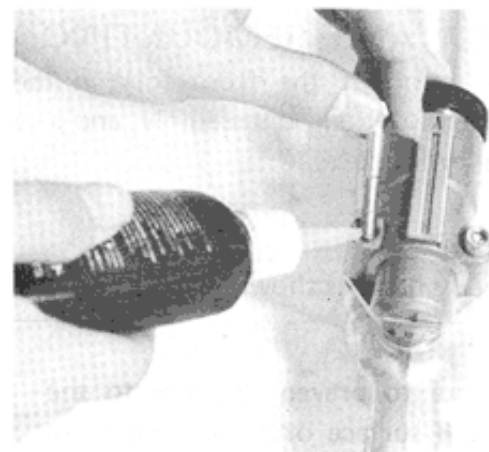

**FORK OIL**

- Be sure to use a front fork oil whose viscosity rating meets the specification below.

Fork oil	Fork oil # 15
Capacity	441 ml

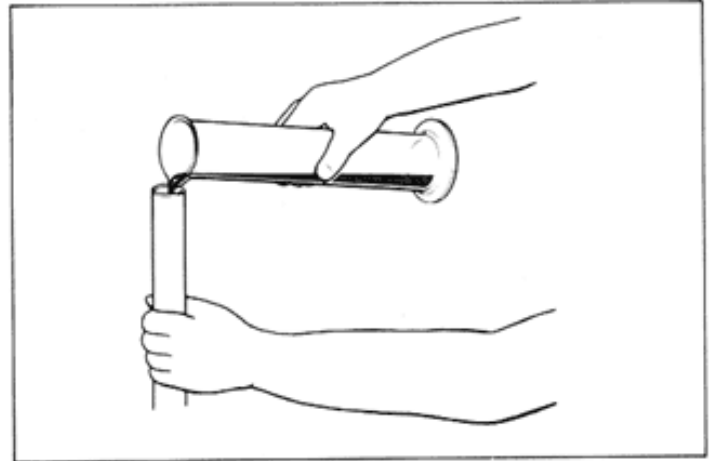

- Hold the front fork vertical and adjust the fork oil level with the special tool.

**NOTE:**

When adjusting oil level, remove the fork springs and compress the inner tube fully.

09943-74111	Fork oil level gauge
Oil level	97 mm

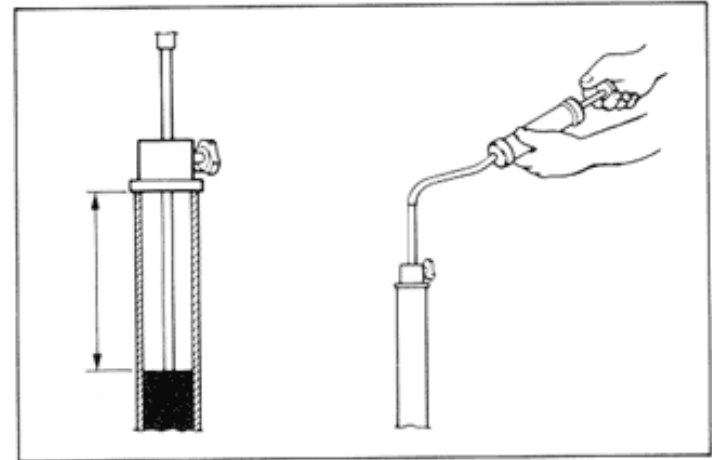
**FORK SPRING**

When installing the fork spring, close pitch end should position in top.

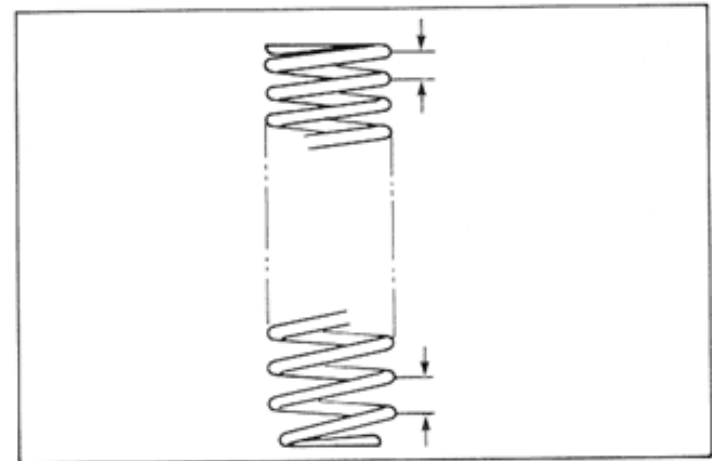
**INNER TUBE**

When installing the front fork assembly, align the line ① of inner tube with the upper surface ② of the upper bracket.



**CLAMP BOLTS AND CAP BOLTS**

Tighten the upper and lower clamp bolts, front fork cap bolts and handlebar mounting bolts to the specified torque.

Item	N·m	kg·m
Front fork upper clamp bolt	20 – 30	2.0 – 3.0
Front fork lower clamp bolt	20 – 30	2.0 – 3.0
Front fork cap bolt	25 – 35	2.5 – 3.5
Handlebar mounting bolt	50 – 60	5.0 – 6.0

**FRONT FORK SETTING****CAUTION:**

When adjusting the front fork, both front forks should be the same condition.

**FRONT FORK SPRING**

Spring pre-load is adjustable for ten steps. Shortening the adjuster length **A** by turning the adjuster ① clockwise makes the spring pre-load larger, and making the adjuster length **A** long makes the spring pre-load small.

Standard setting	No. 5 (from top side)
------------------	-----------------------

**FORK AIR**

Jack up the front of the chassis or engine till all weight is removed from the front end of the motorcycle. Remove the air valve protection cap ② and press the air valve to equalize the fork air with atmospheric pressure. This procedure must be done when the forks are cold.

**CAUTION:**

Be sure to keep air pressure at 0 kg/cm<sup>2</sup>.

**POSI-DAMPING UNIT**

Damping force can be adjustable by turning the adjuster. Turning the adjuster clockwise makes the damping force large and counterclockwise small.

Standard setting	No. 2 position
------------------	----------------

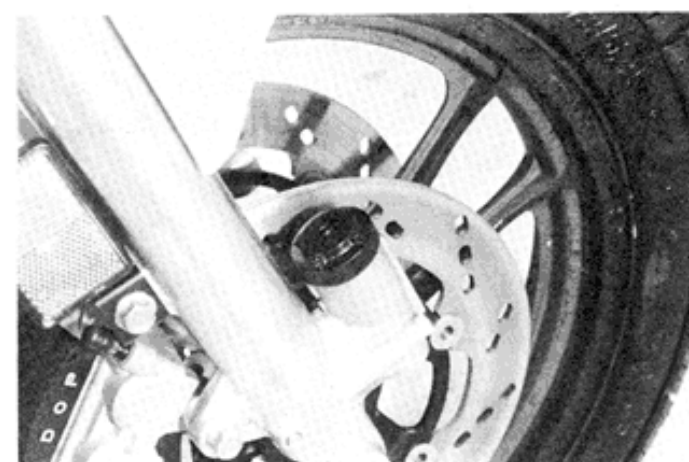
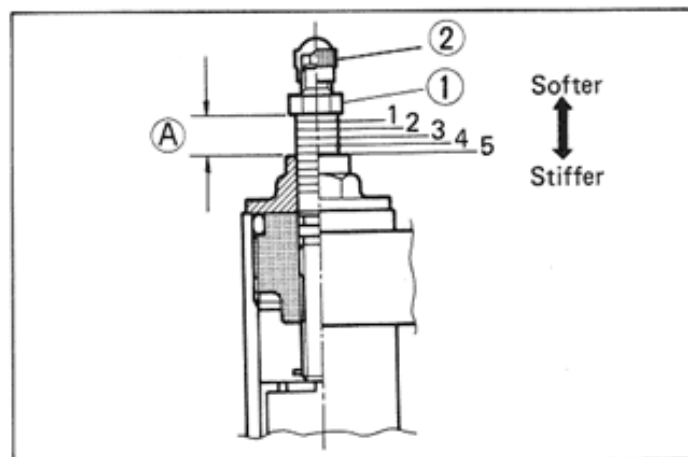

## STEERING STEM

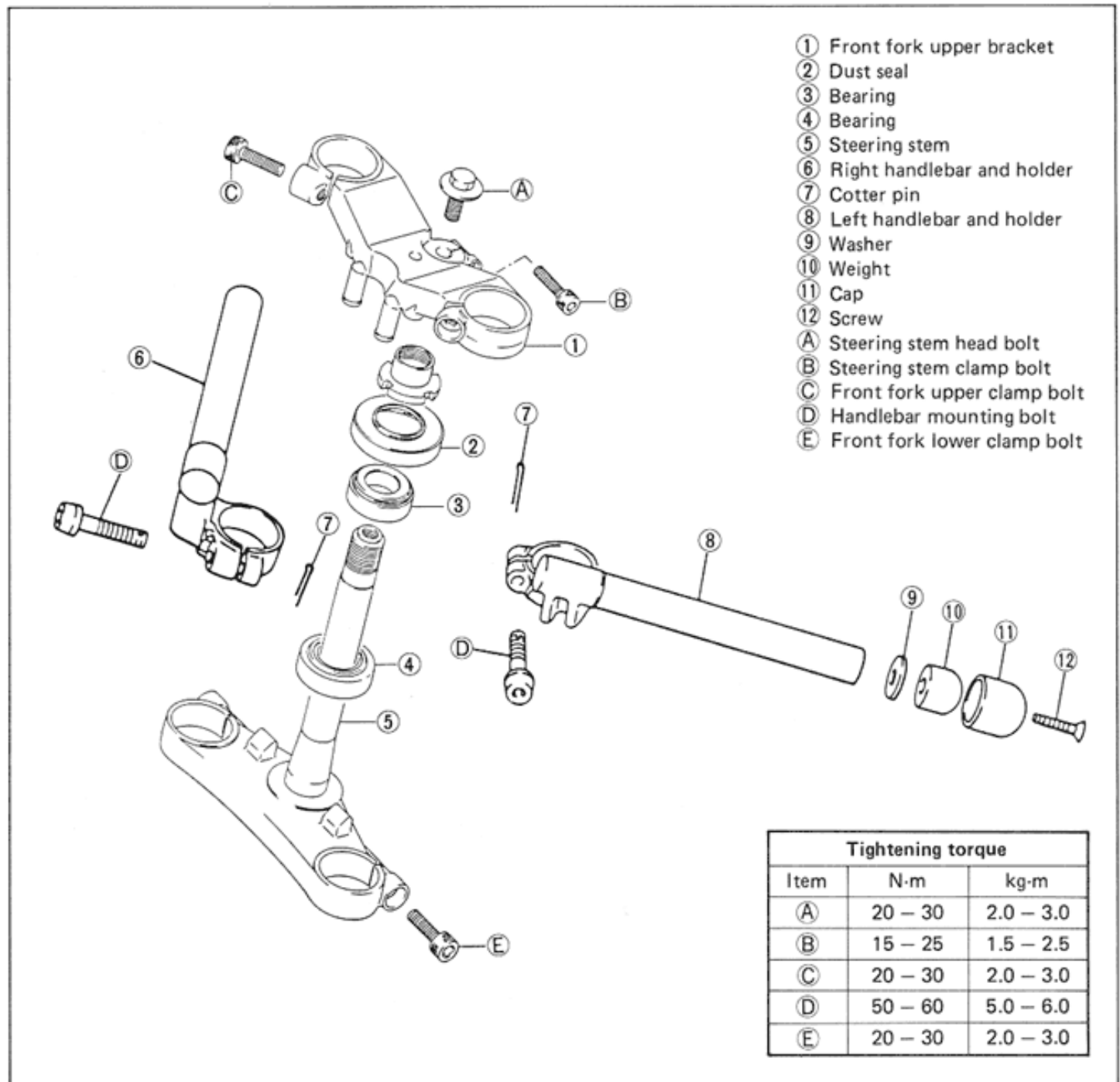

## REMOVAL AND DISASSEMBLY

- Remove the fairing. (Refer to page 7-1)
- Remove the front wheel. (Refer to page 7-4)
- Remove the front fork. (Refer to page 7-16)
- Remove the meter assembly by loosening three bolts.

09900-00401

L-type hexagon wrench set



- Disconnect the lead wires of the meter assembly and the headlight assembly.

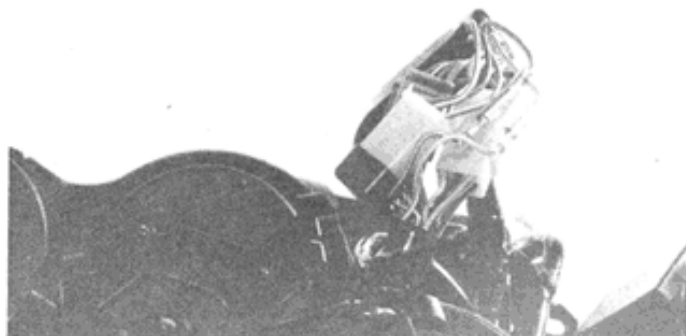

- Remove the headlight assembly.

09900-00401	L-type hexagon wrench set
-------------	---------------------------

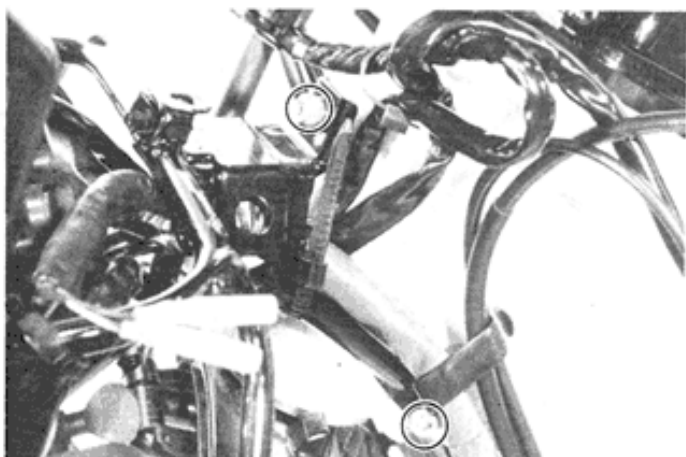

- Remove the front brake hose connector by loosening two bolts.

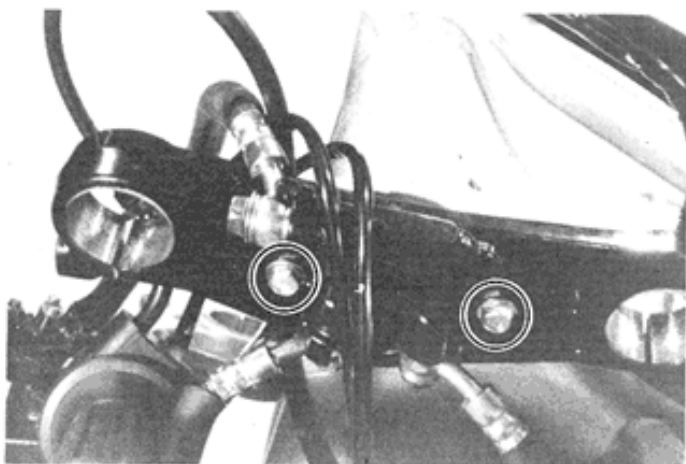

- Remove the ignition switch assembly by loosening two bolts.

09900-00401	L-type hexagon wrench set
-------------	---------------------------

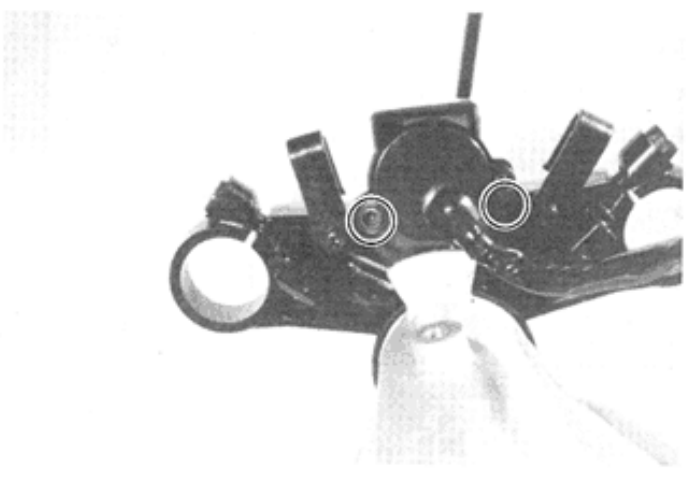

- Remove the steering stem head bolt ① and steering stem clamp bolt ②.

**Tightening torque:**

Item	N·m	kg·m
Steering stem head bolt	20 – 30	2.0 – 3.0
Steering stem clamp bolt	15 – 25	1.5 – 2.5

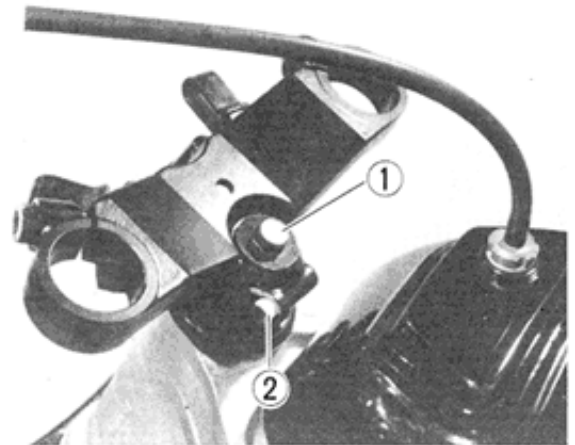

- Remove the steering stem nut by using the special tool, then draw out the steering stem.

09940-14911	Steering stem nut wrench
-------------	--------------------------

**NOTE:**

Hold the steering stem lower bracket by hand to prevent it from falling.

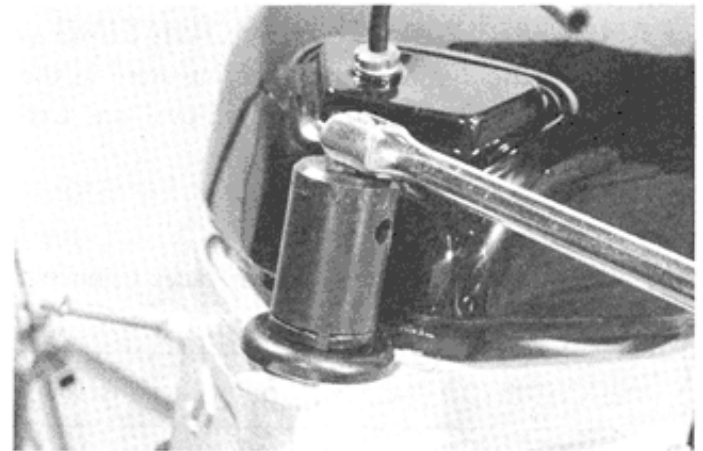

- Draw out the lower steering stem bearing by using the special tool.

**CAUTION:**

The removed bearing should be replaced.

09941-84510	Bearing remover
-------------	-----------------

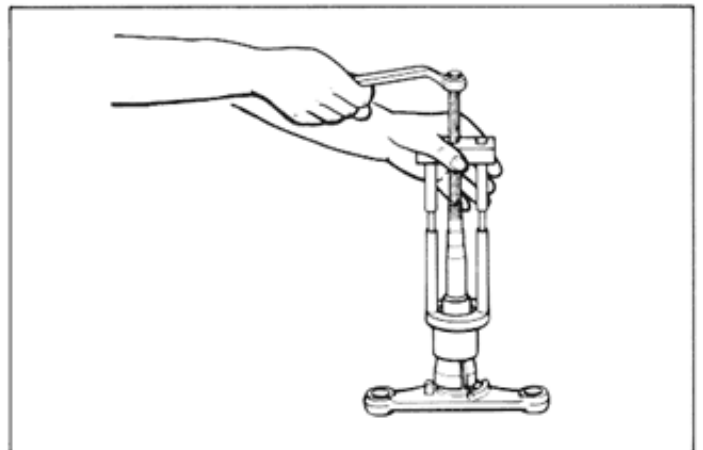

- Push out the steering stem bearing races, upper and lower, by using the appropriate drift.

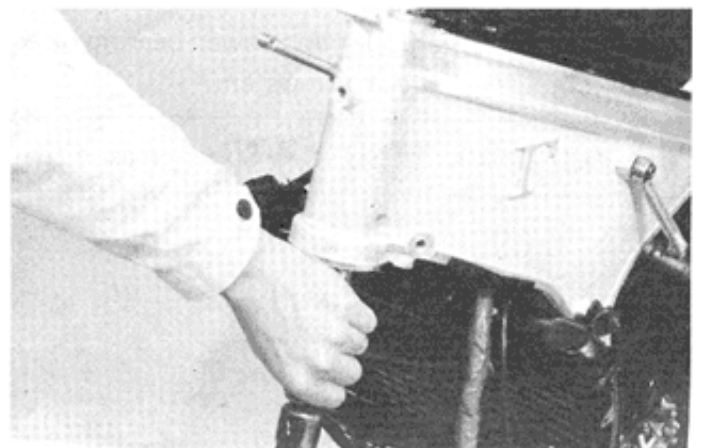

- Push out the steering stem bearing races, upper and lower, by using the special tools.

09941-54911	Steering outer race remover
09941-74910	Steering bearing remover

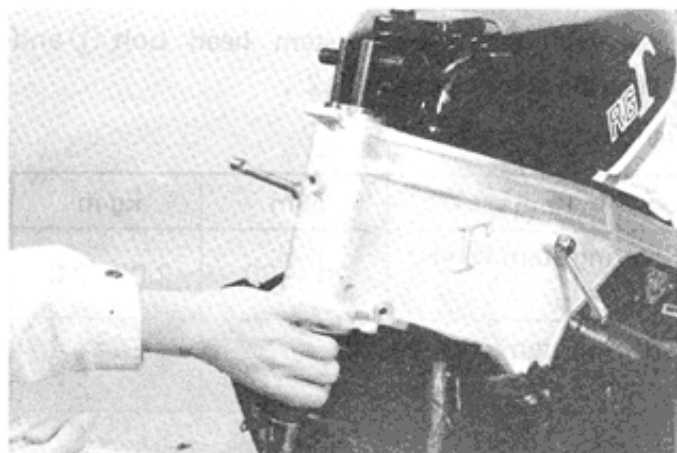

## REASSEMBLY AND REMOUNTING

Reassemble and remount the steering stem in the reverse order of disassembly and removal, and also carry out the following steps.

### OUTER RACES

Press in the upper and lower outer races using the special tool.

09941-34513	Steering outer race installer
-------------	-------------------------------

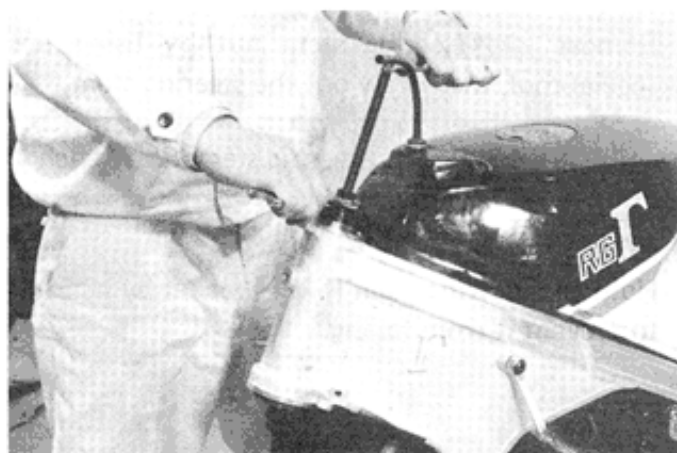

### BEARING

Place an appropriate washer and press in the lower bearing by using the special tool.

09941-74910	Steering bearing installer
-------------	----------------------------

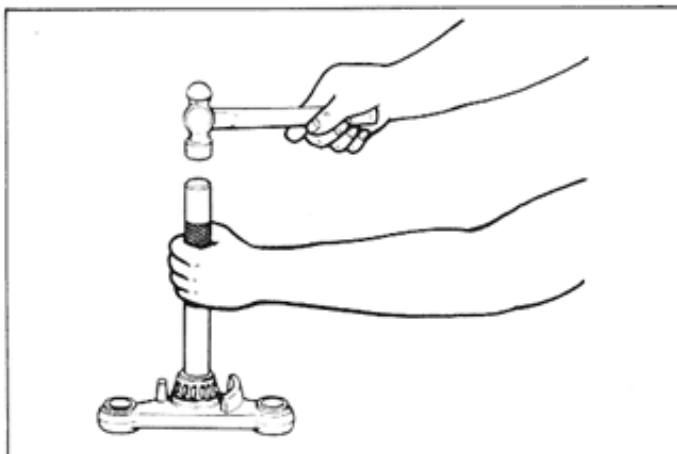

Apply grease to the upper and lower bearing races before remounting the steering stem.

99000-25010	SUZUKI Super grease "A"
-------------	-------------------------

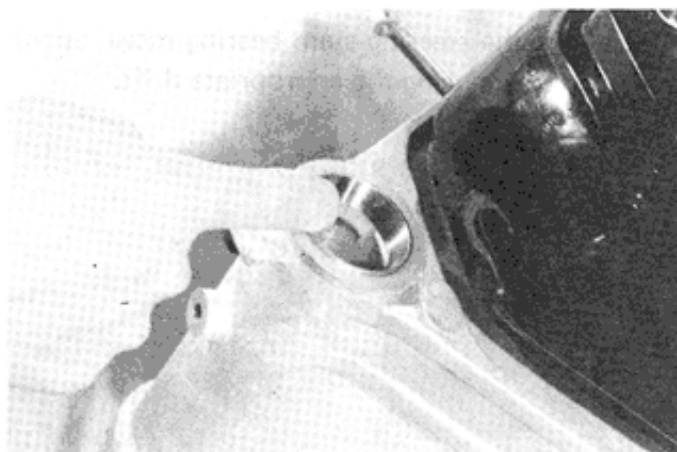

**STEM NUT**

Fit the dust seal to the stem nut.

Tighten the steering stem nut to the specified torque.

Tightening torque	14 – 20 N·m (1.4 – 2.0 kg·m)
-------------------	---------------------------------

09940-14911	Steering stem nut wrench
-------------	--------------------------

Turn the steering stem bracket about five or six times to the left and right until it locks in position so that the taper roller bearing will be seated properly.

Turn back the stem nut by 1/4 – 1/2 turn.

**NOTE:**

This adjustment will vary from motorcycle to motorcycle.

Steering stem head bolt should be tightened to the specified torque.

Tightening torque	20 – 30 N·m (2.0 – 3.0 kg·m)
-------------------	---------------------------------

**CAUTION:**

After performing the adjustment and installing the steering stem upper bracket, "rock" the front wheel assembly forward and back to ensure that there is no play and that the procedure was accomplished correctly. Finally check to be sure that the steering stem moves freely from left to right with own weight. If play or stiffness is noticeable, re-adjust the steering stem nut.

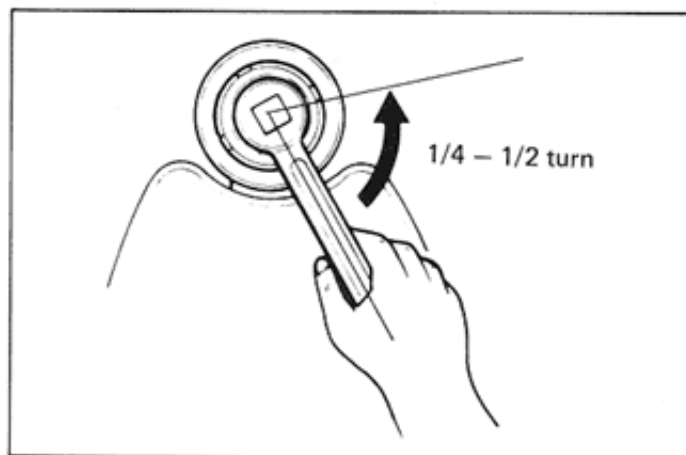
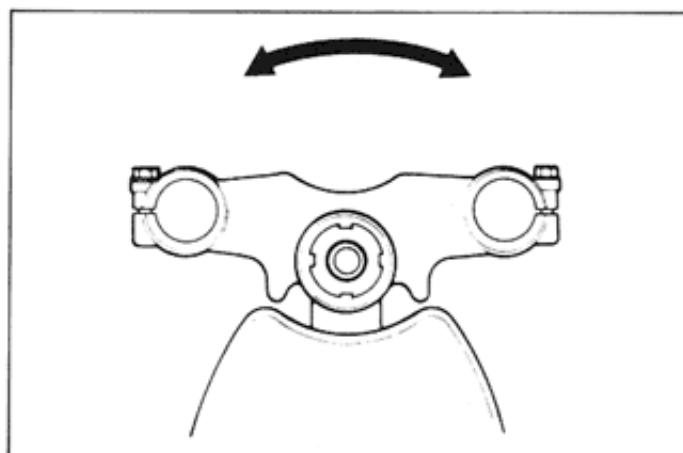
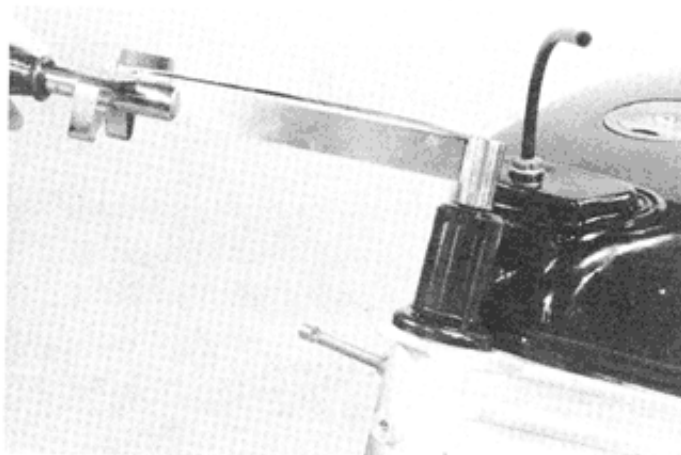

## REAR BRAKE

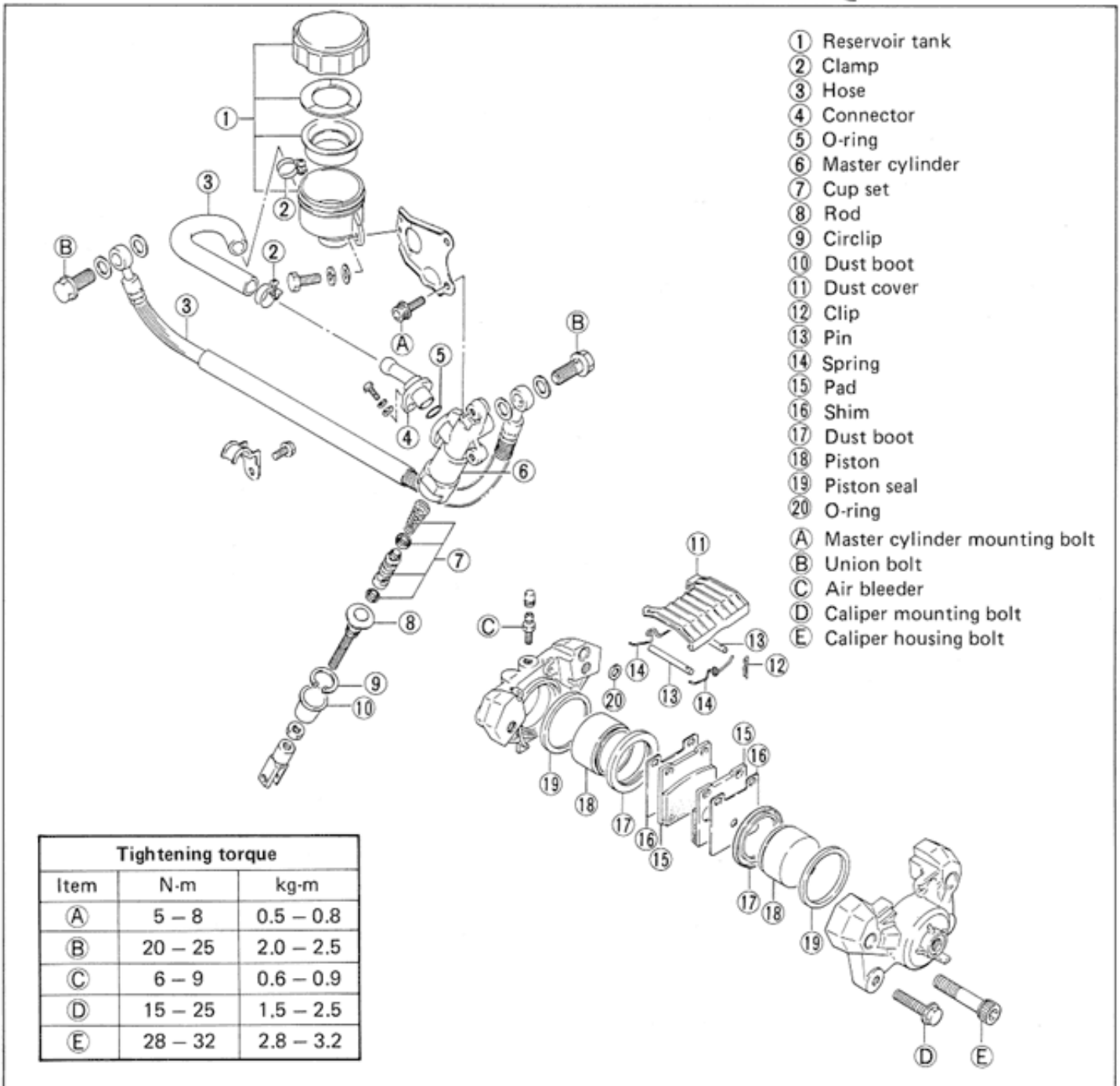

### BRAKE PAD REPLACEMENT

- Remove the dust cover.
- Remove the clips ① and draw out the pins ③. Remove the springs ②.
- Take out the shims and pads.

#### CAUTION:

- \* Do not operate the brake pedal while dismantling the pads.
- \* Replace the brake pad as a set, otherwise braking performance will be adversely affected.

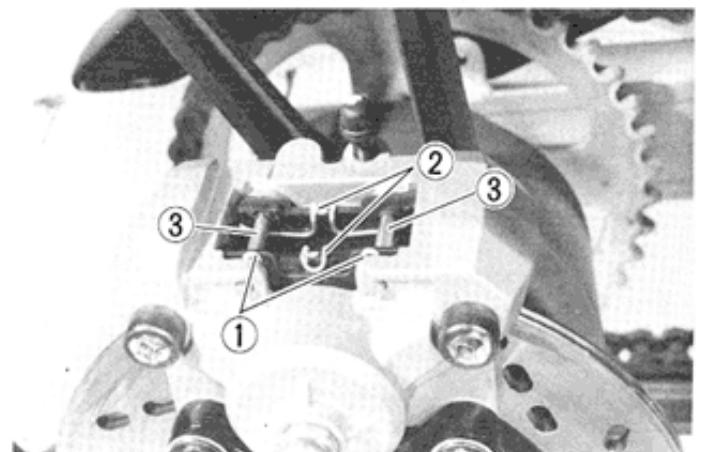

## CALIPER REMOVAL AND DISASSEMBLY

- Remove the union bolt and catch the brake fluid in a suitable receptacle.
- Remove the caliper mounting bolts.

### NOTE:

Slightly loosen the caliper housing bolts to facilitate later disassembly before removing the caliper mounting bolts.

- Remove the pads. (Refer to page 7-29)
- Remove the caliper housing bolts and separate the caliper halves.

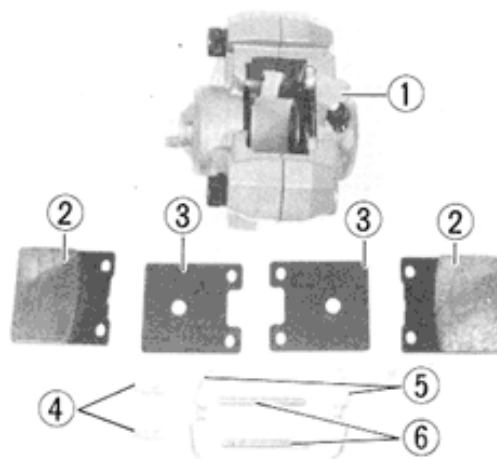
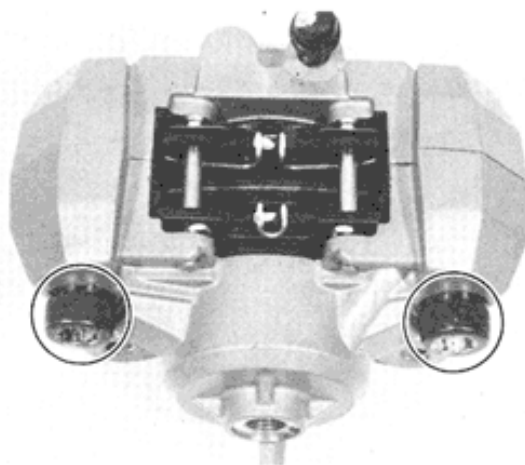
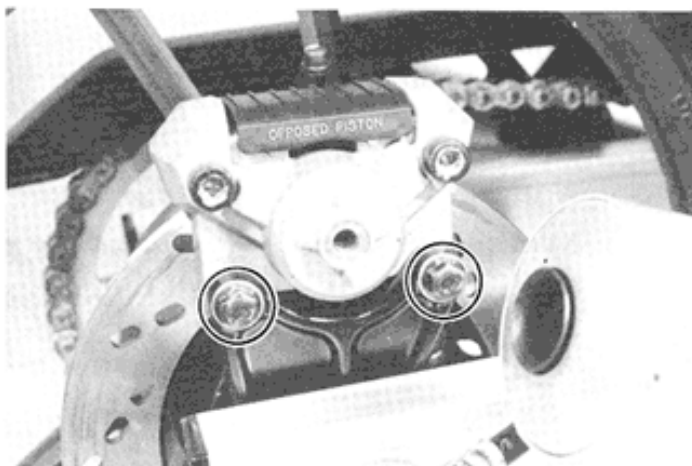

- ① Caliper
- ② Pad
- ③ Shim
- ④ Clip
- ⑤ Spring
- ⑥ Pin

- Remove the O-ring.

### NOTE:

Once separate the caliper halves, replace the O-ring with a new one.

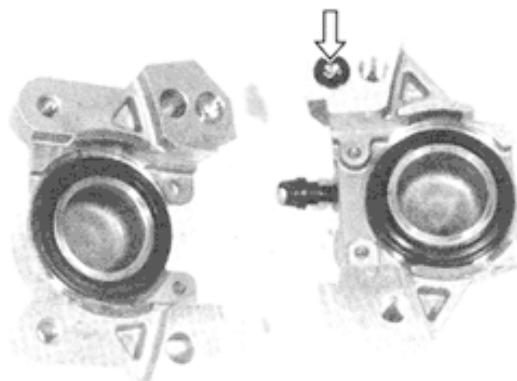

- Place a rag over the piston to prevent it from popping out and push out the piston by using air gun.

**CAUTION:**

To prevent piston damage, do not use high pressure air.

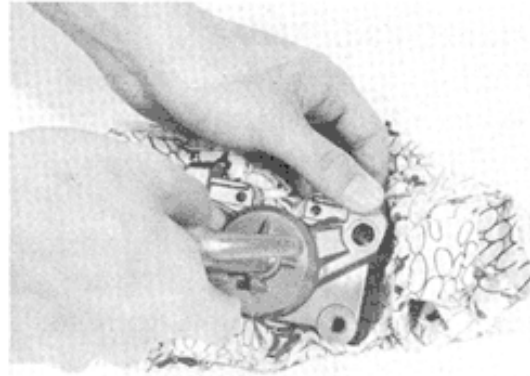

- Remove the piston ①, dust boot ②, piston seal ③ and O-ring ④.

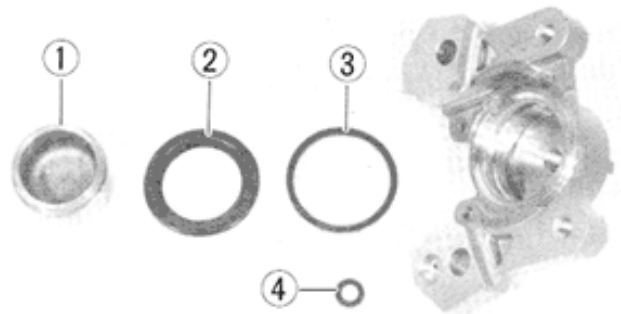

**INSPECTION**

**CYLINDER AND PISTON**

- Inspect the cylinder bore wall for nicks, scratches or other damage.
- Inspect the piston surface for any flaws or other damage.

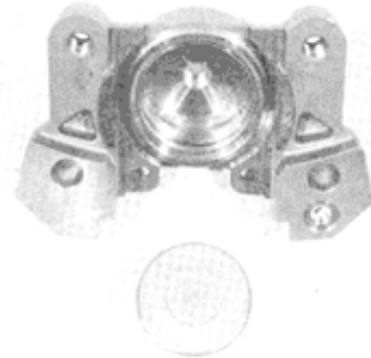

**RUBBER PART**

Inspect the each rubber parts for damage and wear.



**DISC**

- Using a micrometer check the disc for wear. Its thickness can be checked with disc and wheel in place. The service limit for the thickness of the disc is shown below:

09900-20205	Micrometer (0 – 25 mm)
Service Limit (Rear disc)	5.3 mm

- With the disc mounted on the wheel, check the disc for face runout with a dial gauge, as shown.

09900-20606	Dial gauge (1/100 mm)
09900-20701	Magnetic stand
Service Limit	0.30 mm

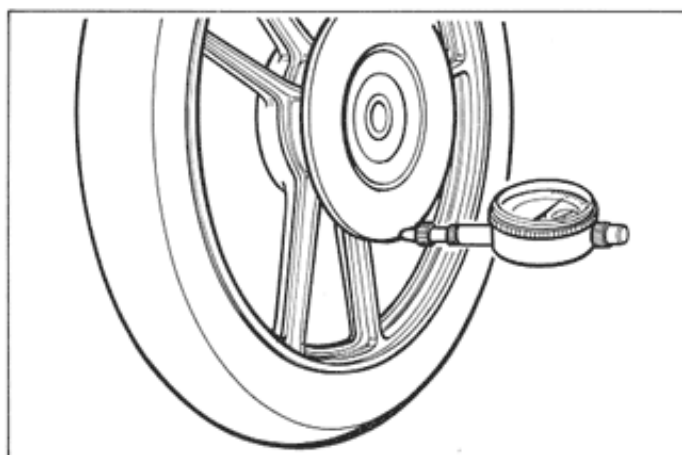
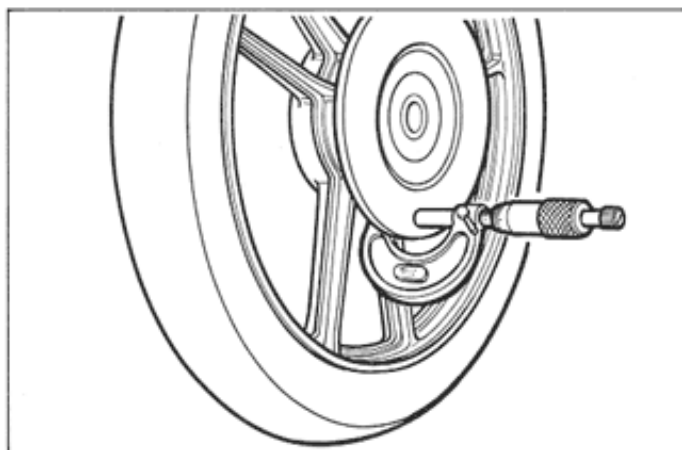
**REASSEMBLY**

Reassemble and remount the caliper in the reverse order of disassembly and removal, and also carry out the following steps:

**CAUTION:**

- \* Wash the caliper components with fresh brake fluid before reassembly.
- \* Never use cleaning solvent or gasoline to wash them.
- \* Apply brake fluid to the caliper bore and piston to be inserted into the bore.
- \* Bleed the air after reassembling the caliper (See page 2-14).

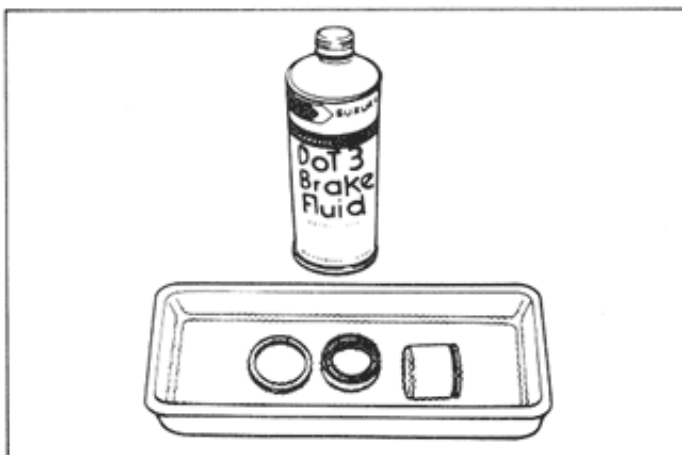
**TIGHTENING TORQUE**

Item	N-m	kg-m
Union bolt	20 – 25	2.0 – 2.5
Caliper housing bolt	28 – 32	2.8 – 3.2
Caliper mounting bolt	15 – 25	1.5 – 2.5



## MASTER CYLINDER REMOVAL AND DISASSEMBLY

- Remove the seat.
- Remove the right side frame cover by loosening two screws.

09900-00401

L-type hexagon wrench set



- Pull out the cotter pin ① and take off the pin ②.

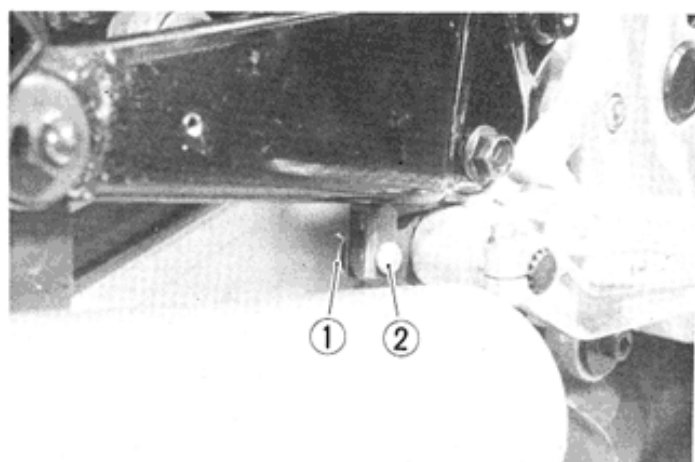

- Remove the two master cylinder mounting bolts.

09900-00401

L-type hexagon wrench set

Tightening torque

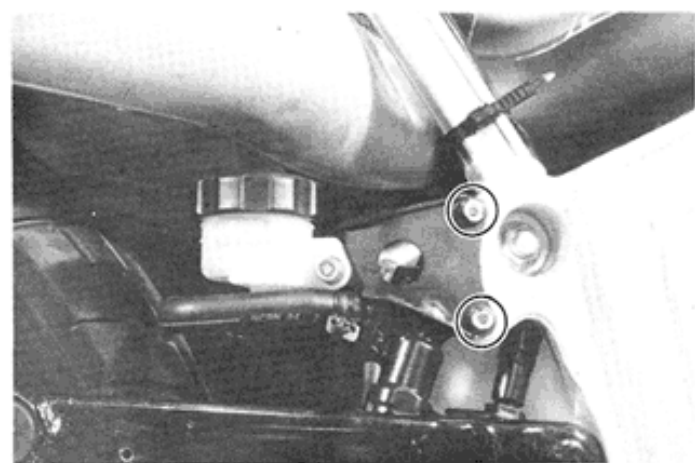
5 – 8 N·m  
(0.5 – 0.8 kg·m)

- Place a cloth underneath the union bolt on the master cylinder to catch spilled drops of brake fluid. Unscrew the union bolt and disconnect the brake hose from the master cylinder joint.

### CAUTION:

Immediately and completely wipe off any brake fluid contacting any part of the motorcycle. The fluid reacts chemically with paint, plastics and rubber materials, etc. and will damage them severely.

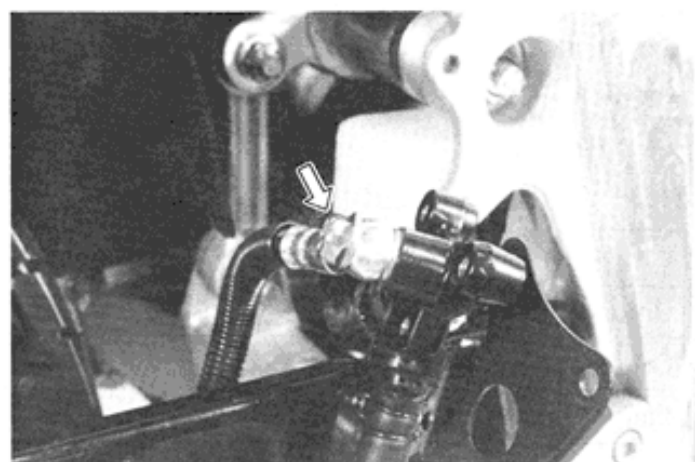

- Disconnect the reservoir tank hose by loosening a clamp screw.
- Drain the fluid from the reservoir tank.

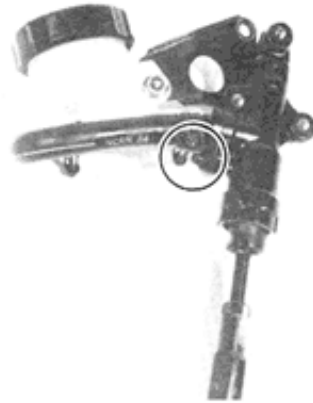

- Remove the connector by loosening a screw and then remove the O-ring.

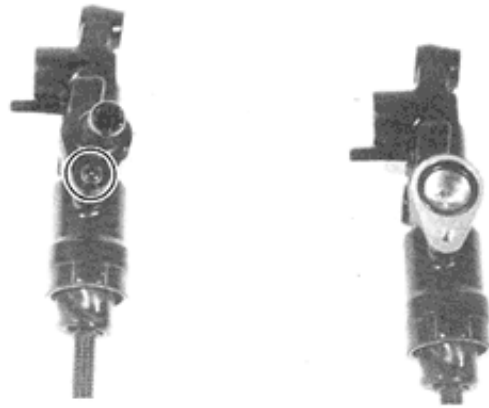

- Remove the dust boot.
- Remove the circlip by using the special tool.

09900-06105	Snap ring pliers
-------------	------------------



- Draw out the rod ①, piston ②, primary cup ③ and spring ④.



## INSPECTION

### CYLINDER

Inspect the cylinder bore wall for any scratches or other damage.



### PISTON, CUP SET AND RUBBER PARTS

Inspect the piston surface for scratches or other damage.

Inspect the cup set and each rubber parts for damage.

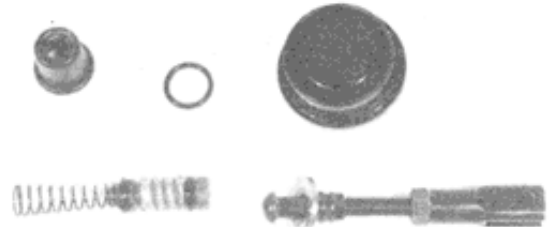

## REASSEMBLY AND REMOUNTING

Reassemble and remount the master cylinder in the reverse order of removal and disassembly, and also carry out the following steps:

### CAUTION:

Wash the master cylinder components with fresh brake fluid before reassembly. Never use cleaning solvent or gasoline to wash them. Apply brake fluid to the cylinder bore and all the internals to be inserted into the bore.

### CAUTION:

Bleed the air after reassembling master cylinder. (Refer to page 2-14)  
Adjust the rear brake light switch and brake pedal height after installation. (Refer to page 2-13)

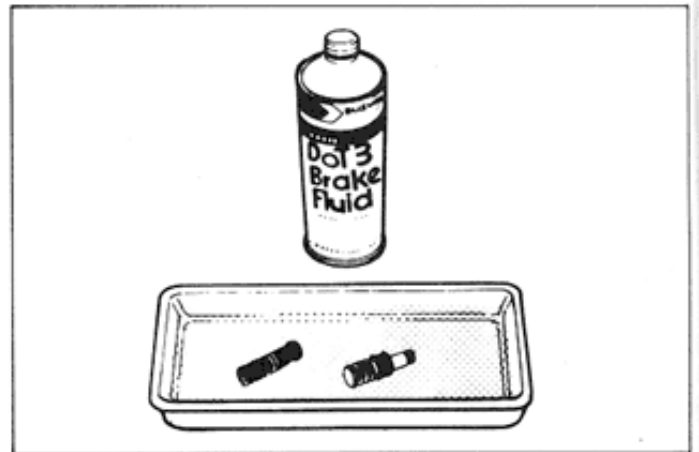

### REAR BRAKE PEDAL

When reinstalling a new brake pedal, align the both punched marks ① on the brake pedal and on the end face of the brake pedal rod arm.

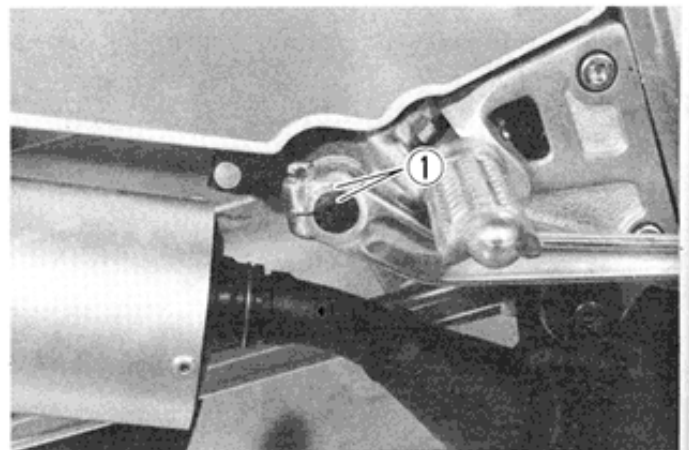

## REAR WHEEL

### CONSTRUCTION

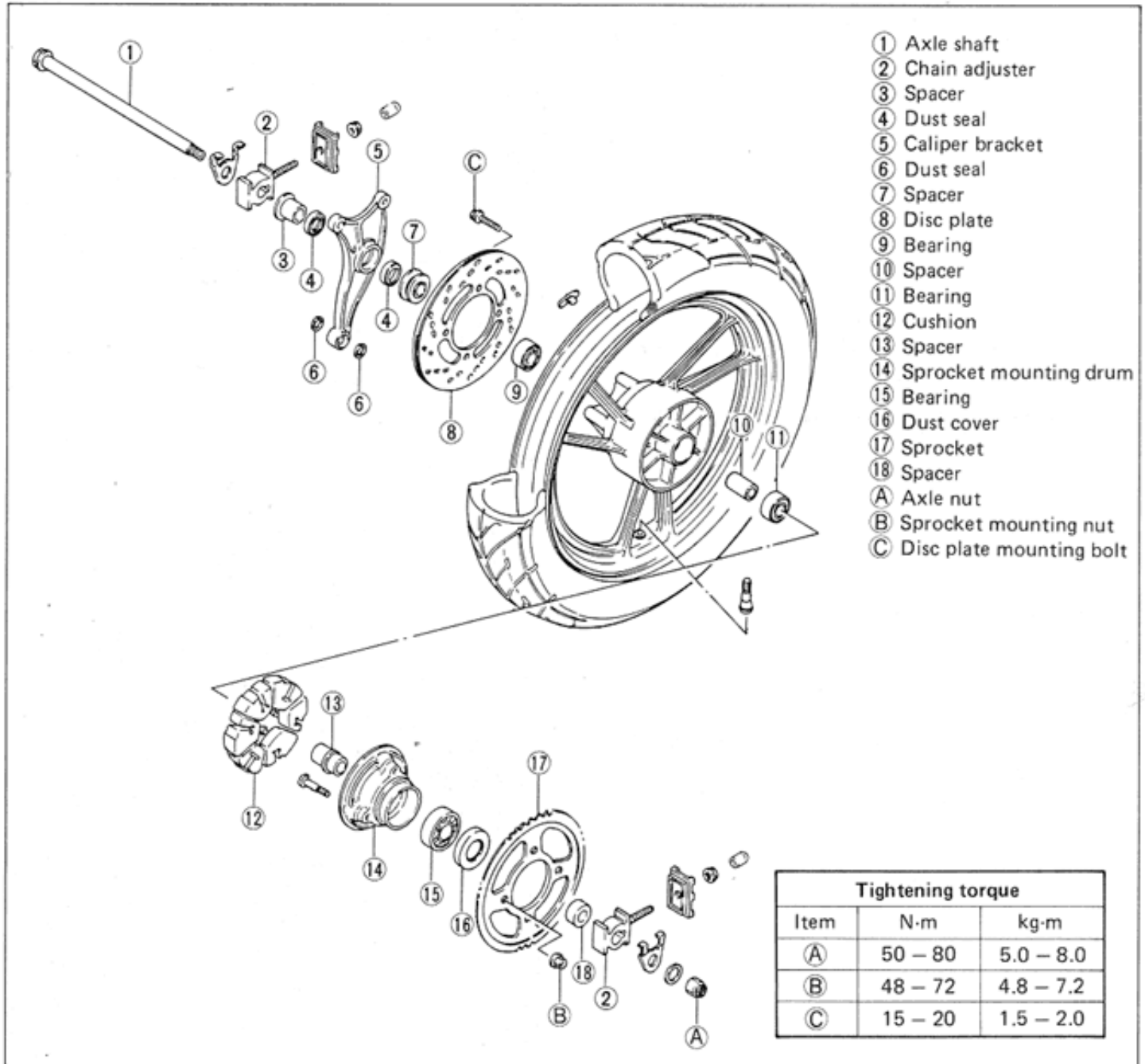

### REMOVAL AND DISASSEMBLY

- Support the motorcycle by using jack with wooden block.

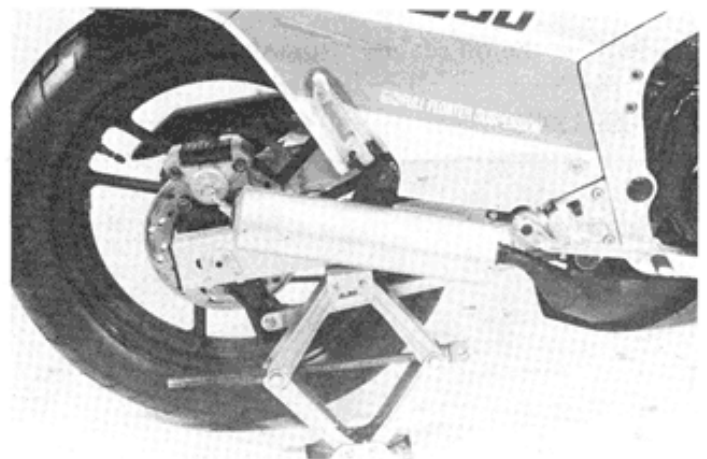

- Remove the rear brake caliper mounting bolts and take off the caliper.
- Remove the nut of the torque link for rear side.

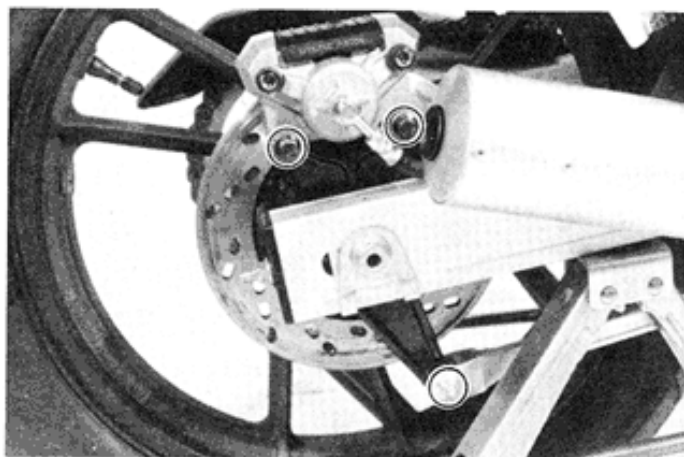

- Loosen the axle nut and the chain adjuster nuts.
- Draw out the axle shaft.
- Disengage the drive chain from the rear sprocket and remove the rear wheel.

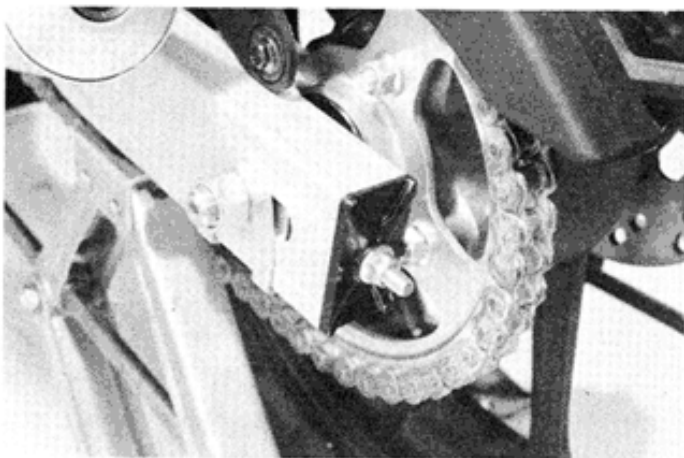

- Separate the rear sprocket mounting drum from the wheel.

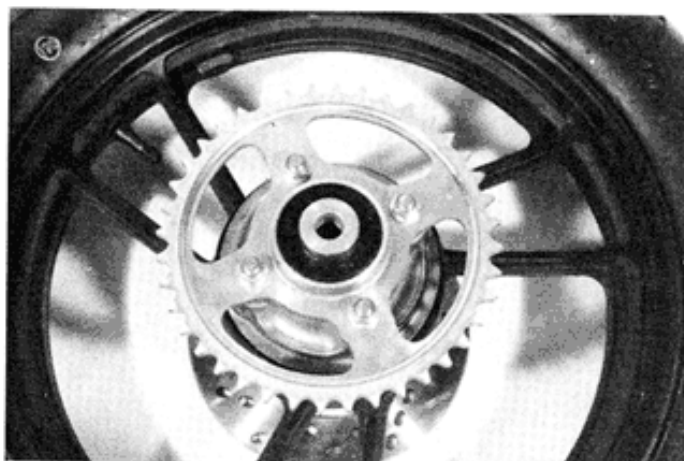

- Remove the oil seal by using the special tool.

09913-50121

Oil seal remover

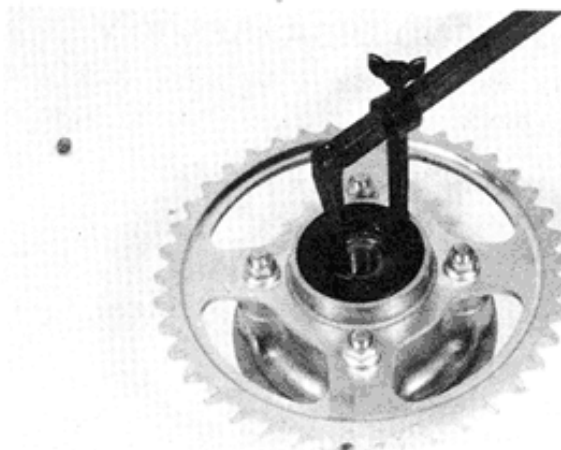

- Drive out the sprocket mounting drum bearing as well as front wheel bearing. (Refer to page 7-5)

**CAUTION:**

The removed bearing should be replaced.

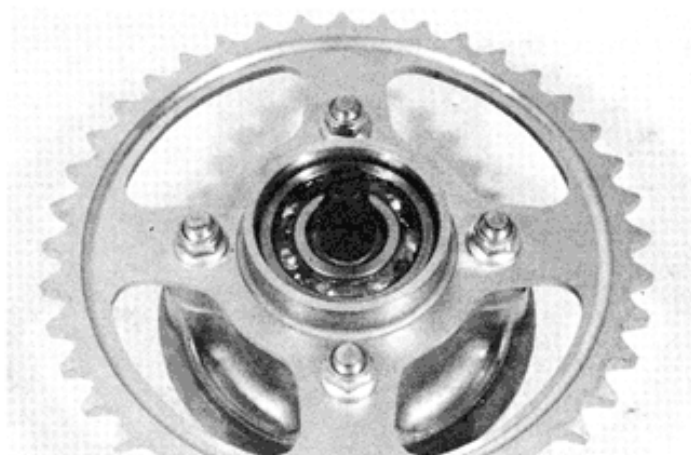

- Separate the rear sprocket from the sprocket mounting drum by loosening four nuts.

Tightening torque	48 – 72 N·m (4.8 – 7.2 kg-m)
-------------------	---------------------------------

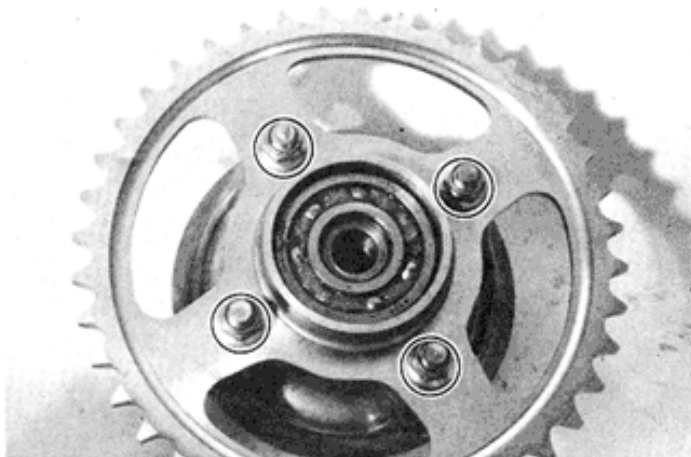

- Separate the disc from the wheel by loosening four allen bolts.

09900-00401	L-type hexagon wrench set
-------------	---------------------------

Tightening torque	15 – 20 N·m (1.5 – 2.0 kg-m)
-------------------	---------------------------------

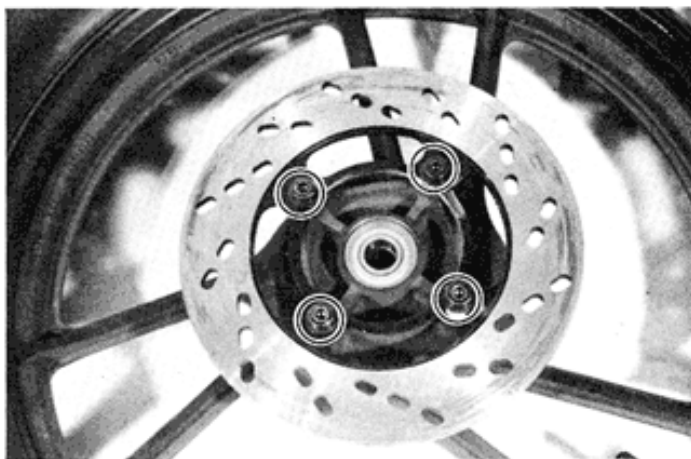

- Drive out the wheel bearings, right and left, as well as front wheel bearing. (Refer to page 7-5)

**CAUTION:**

The removed bearing should be replaced.

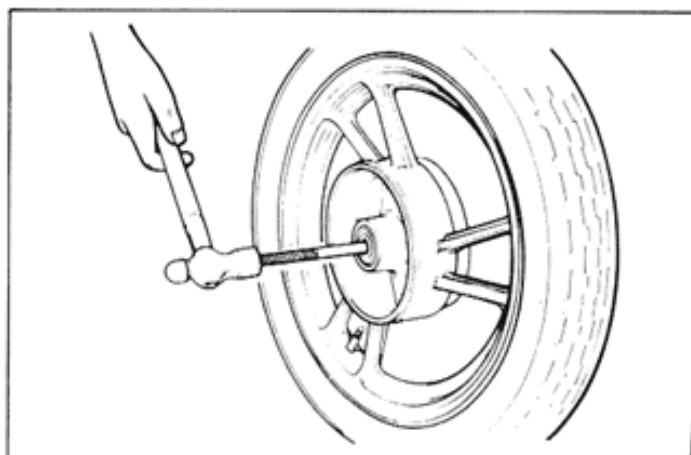

- Remove the six cushions.



## INSPECTION

### WHEEL AND SPROCKET MOUNTING

- DRUM BEARINGS..... Refer to page 7- 6
- AXLE SHAFT ..... Refer to page 7- 6
- WHEEL ..... Refer to page 7- 6
- TIRE ..... Refer to page 2-15

### CUSHION

Inspect the cushions for wear and damage.

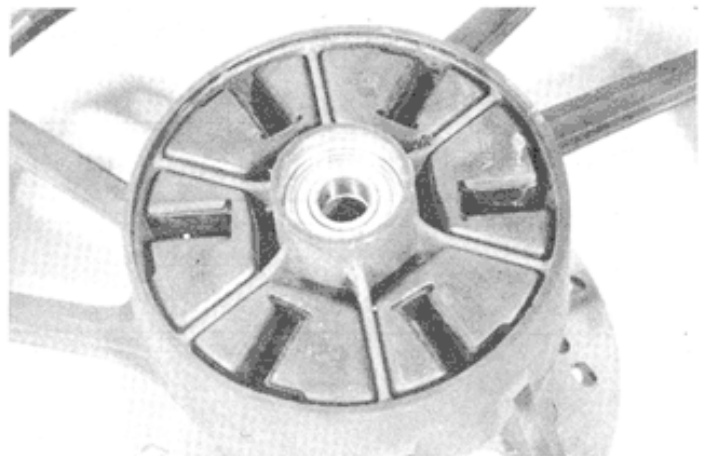

### SPROCKET

Inspect the sprocket teeth for wear. If they are worn as illustrated, replace the sprocket and drive chain.

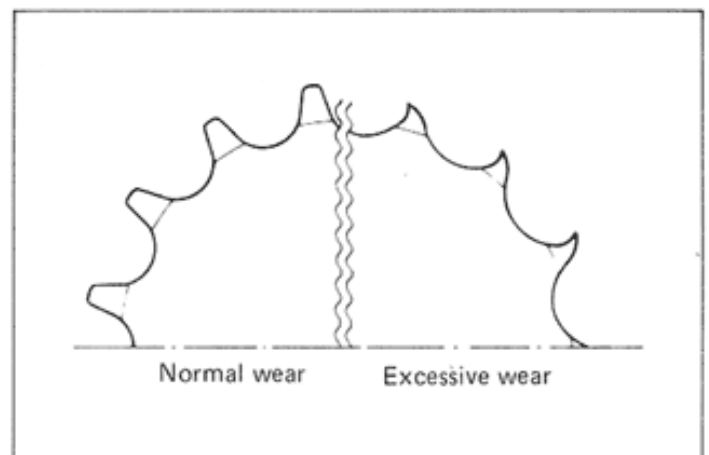

## REASSEMBLY AND REMOUNTING

Reassemble and remount the rear wheel in the reverse order of removal and disassembly, and also carry out the following steps:

### WHEEL AND SPROCKET MOUNTING DRUM BEARINGS

Apply grease before installing the bearings.

99000-25010

SUZUKI super grease "A"



### WHEEL BEARINGS

Install the wheel bearing by using the special tools.

09924-84510

Bearing installer set

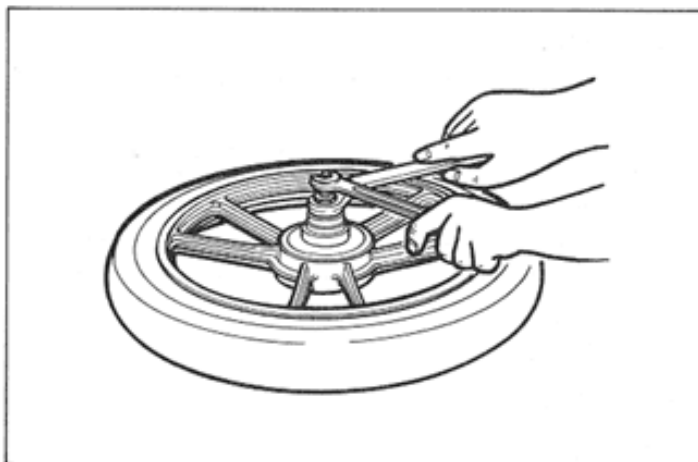

#### NOTE:

First install the wheel bearing for right side.

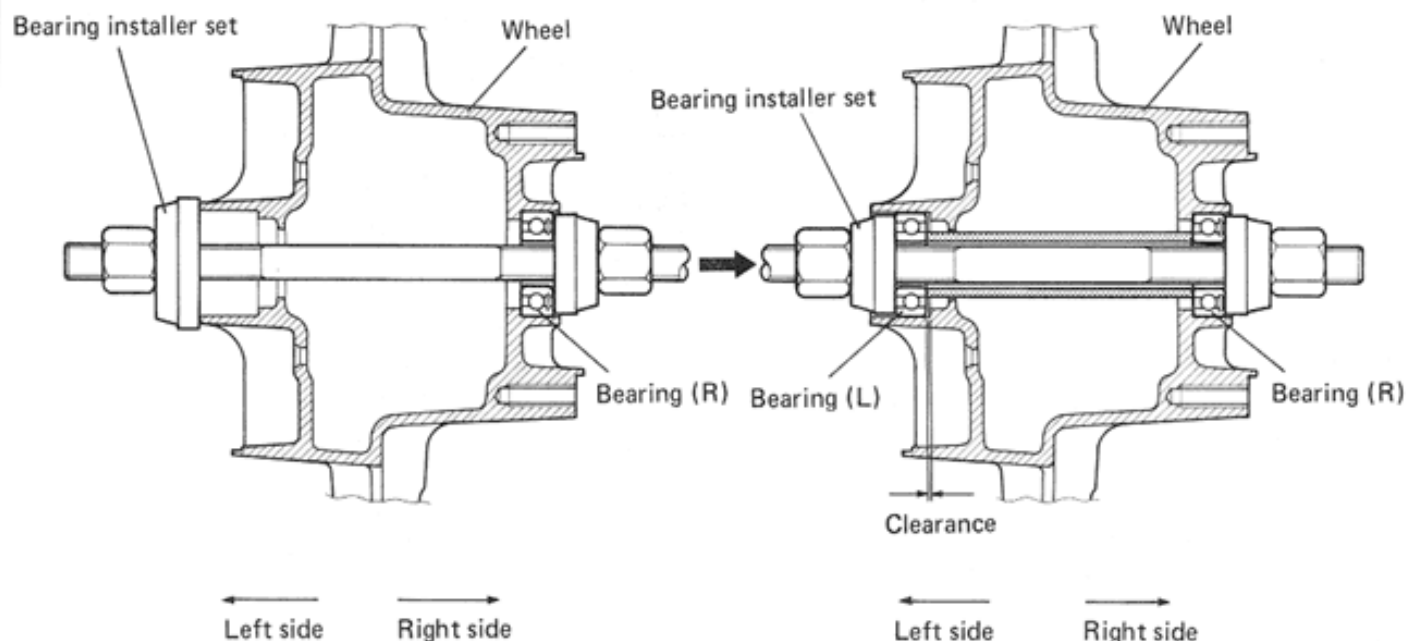

**SPROCKET MOUNTING DRUM BEARING**

Install the bearing by using the special tool.

09913-75520	Bearing installer
-------------	-------------------

**NOTE:**

Apply grease to the bearing and oil seal lip before assembling rear wheel.

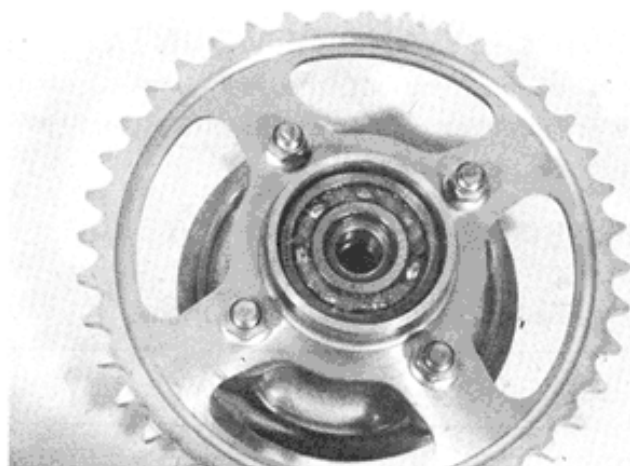
**BRAKE DISC**

- Make sure that the brake disc is clean and free of any greasy matter.
- Apply Thread Lock "1360" to the disc bolts and tighten them to the specified torque.

99000-32130	Thread Lock "1360"
-------------	--------------------

Tightening torque	15 – 20 N·m (1.5 – 2.0 kg·m)
-------------------	---------------------------------

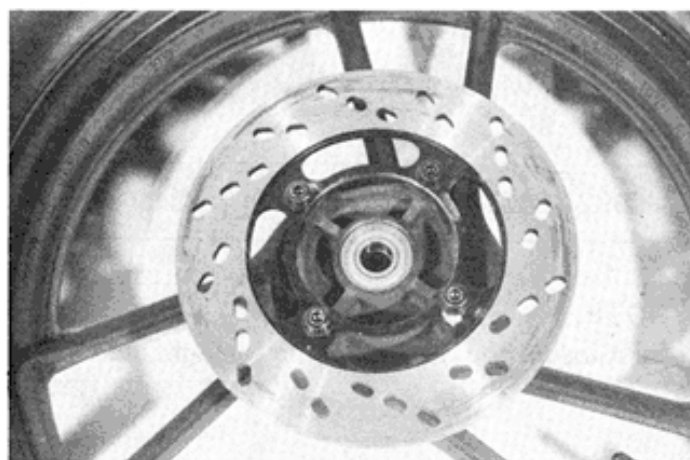
**REAR SPROCKET**

Tighten the rear sprocket nuts to the specified torque.

Tightening torque	48 – 72 N·m (4.8 – 7.2 kg·m)
-------------------	---------------------------------

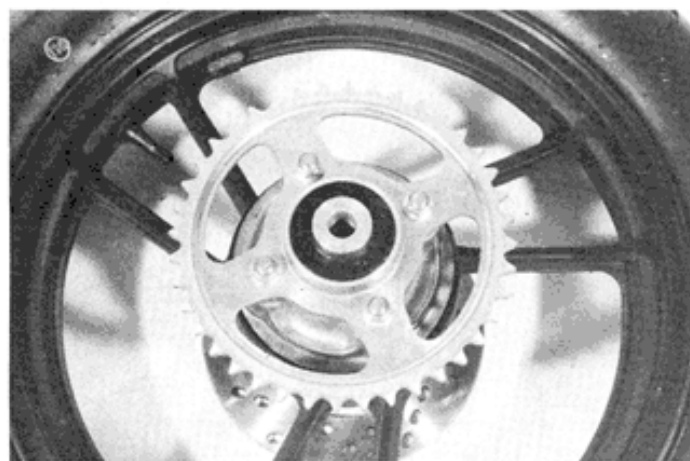
**REAR AXLE SHAFT**

- Adjust the chain slack after rear wheel installation. (Refer to page 2-11)
- Tighten the rear axle nut to the specified torque.

Tightening torque	50 – 80 N·m (5.0 – 8.0 kg·m)
-------------------	---------------------------------

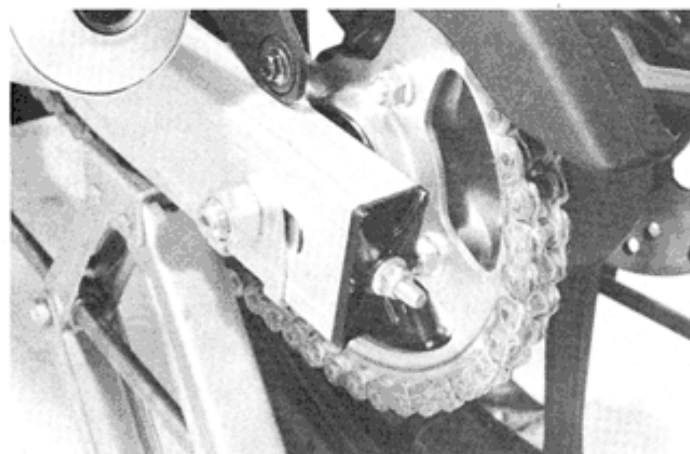

## TIRE AND WHEEL

### REMOVAL

The most critical factor of a tubeless tire is the seal between the wheel rim and the tire bead. Because of this, we recommended using a tire changer which is also more efficient than tire levers.

For tire removal the following tools are required.

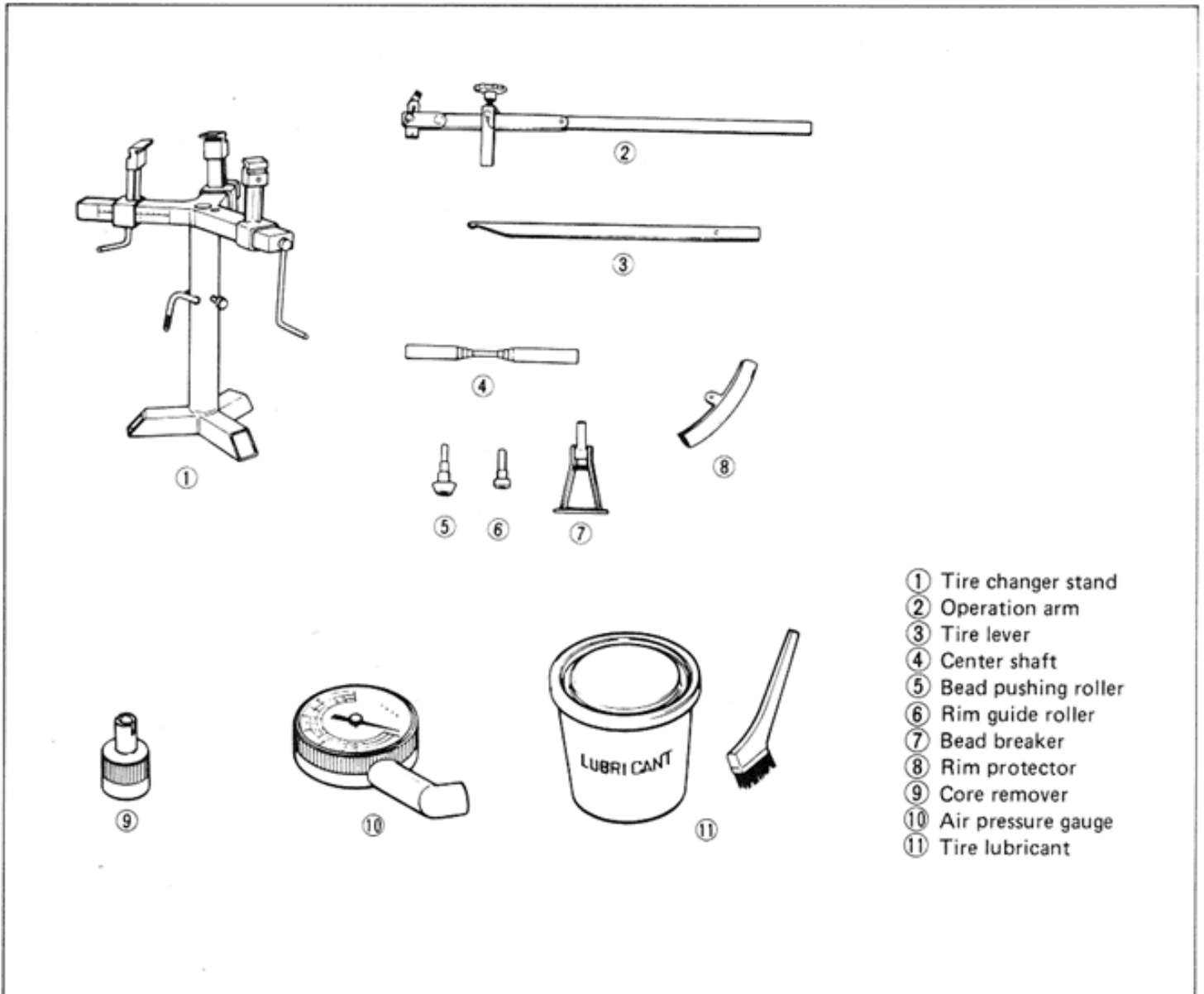

- Remove the valve core from the valve stem, and deflate the tire completely.

#### NOTE:

Mark tire with chalk to note the position ① of the tire on the rim and rotational direction ② of the tire.

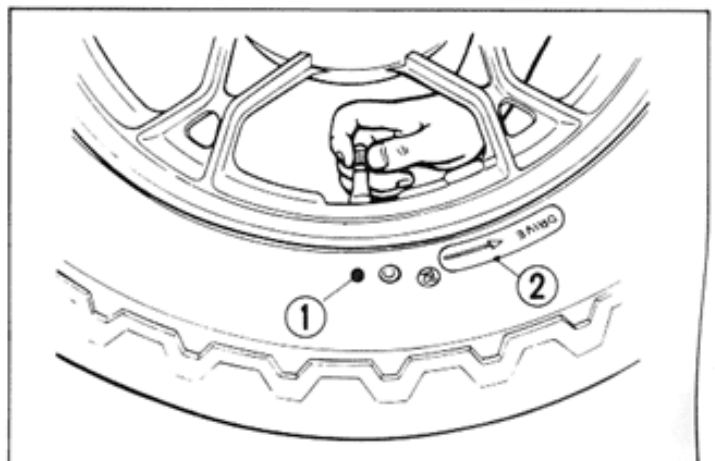

- Place the center shaft ① to the wheel, and fix the wheel firm by the rim holder ②.

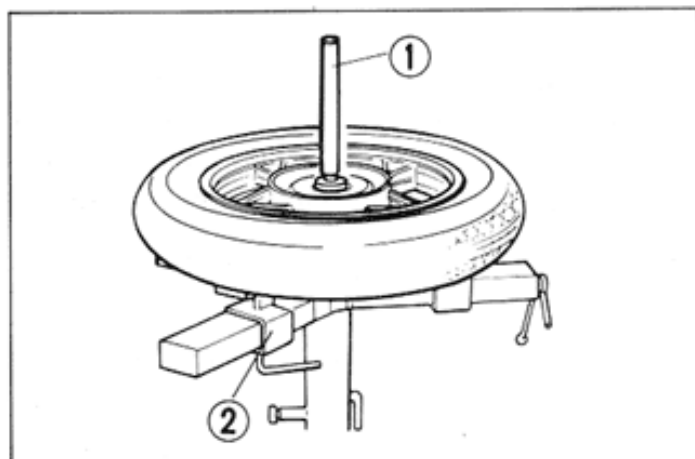

- Attach the operation arm (3) to the center shaft.

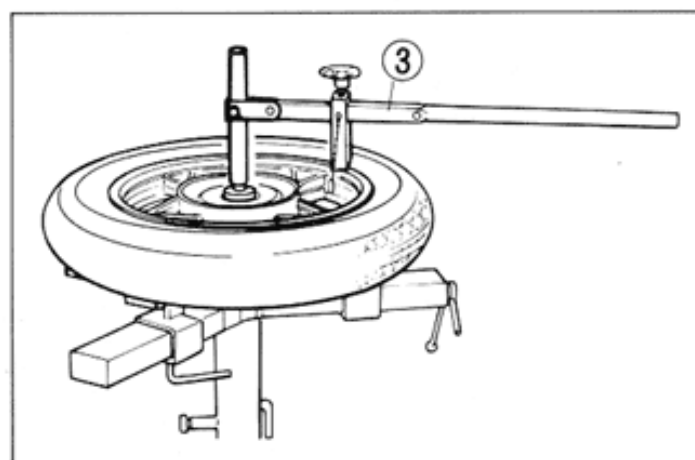

- Attach the bead breaker (4) to the operation arm, and dismount the bead from the rim. Turn the wheel over and dismount the other bead from the rim.

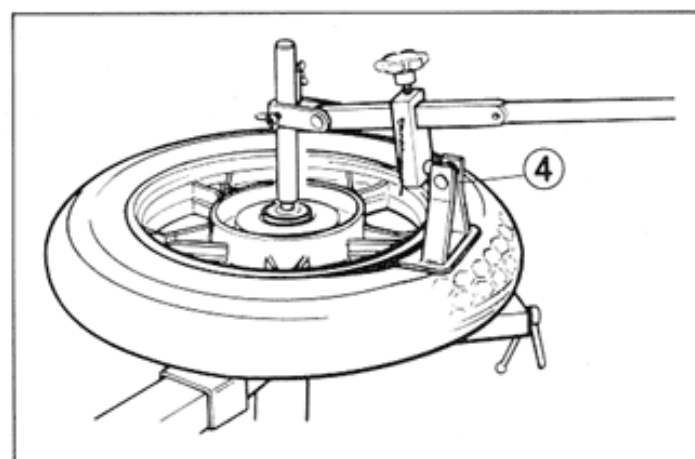

- Install the rim guide roller (5).
- Install the rim protector (6), and raise the tire bead with the tire lever (7).

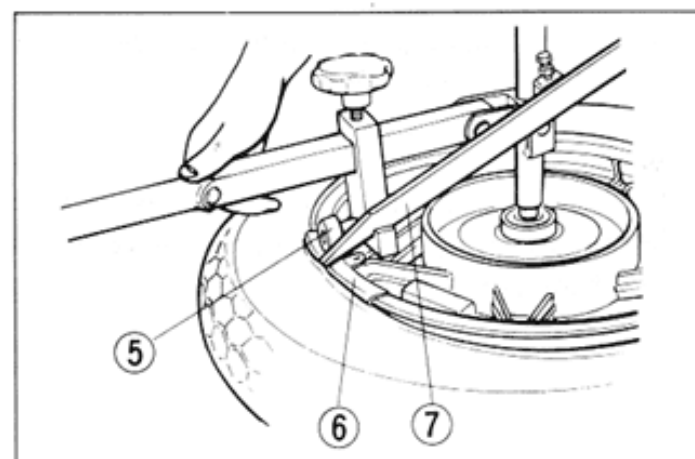

- Set the tire lever against the operation arm, and rotate the lever around the rim. Repeat this procedure to remove the other bead from the rim.

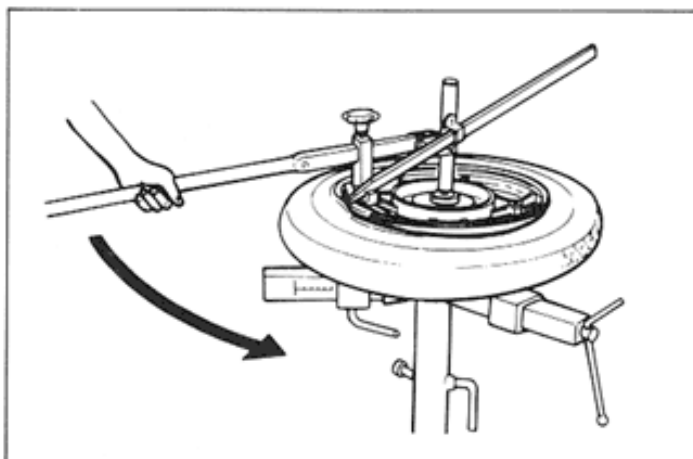

## INSPECTION

### WHEEL

Wipe off any rubber substance or rust from the wheel, and inspect the wheel rim. If any one of the following items is observed, replace it with a new wheel.

- \* A distortion or crack.
- \* Any scratches or flaws in the bead seating area.
- \* Wheel runout (Axial & Radial) of more than 2.0 mm.

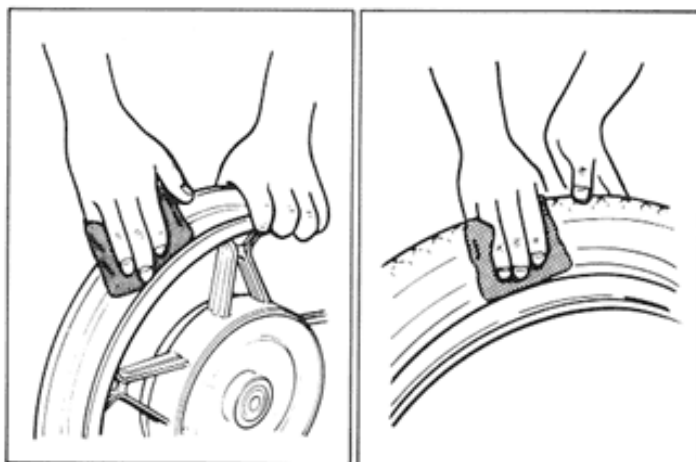

### TIRE

Thoroughly inspect the removed tire, and if any one of the following items is observed, do not repair the tire. Replace with the new one.

- \* A puncture or a split whose total length or diameter exceeds 6 mm.
- \* A scratch or split at the side wall.
- \* Tread depth less than 1.6 mm in the front tire and less than 2.0 mm in the rear tire.
- \* Ply separation.
- \* Tread separation.
- \* Tread wear is extraordinarily deformed or distributed around the tire.
- \* Scratches at the bead.
- \* Cord is cut.
- \* Damage from skidding (flat spots).
- \* Abnormality in the inner liner.

## REPAIR

### NOTE:

When repairing a flat tire, follow the repair instructions and use only recommended repairing materials.

## VALVE

### INSPECTION

Inspect the valve after the tire is removed from the rim, and replace with the new valve if the seal rubber has any split or scratch.

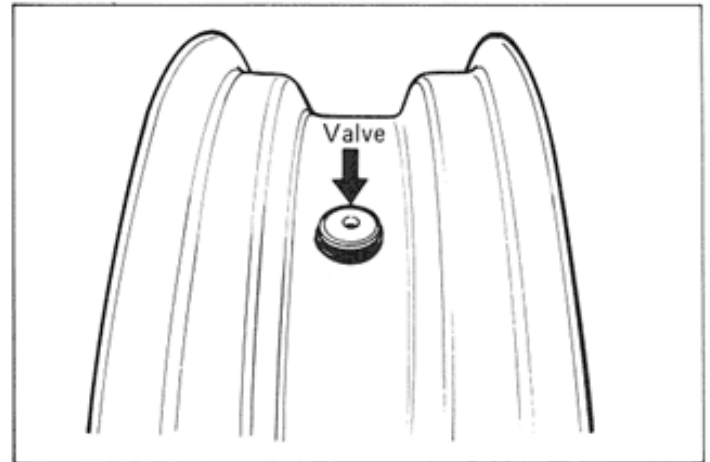

Inspect the removed valve core and replace with the new one if seal rubber is abnormally deformed or worn.

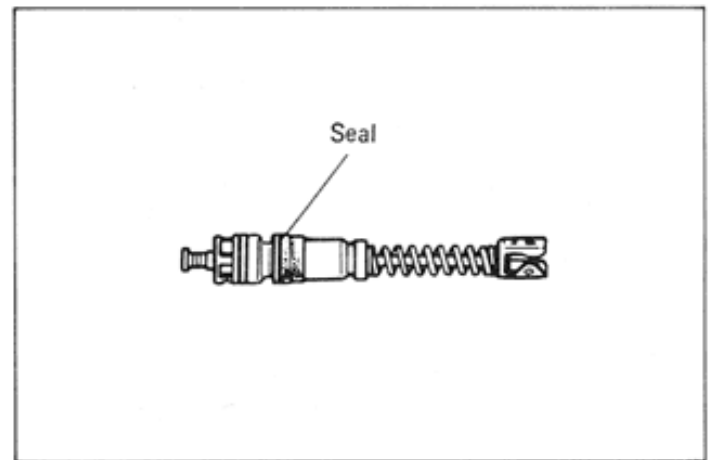

### INSTALLATION

Any dust or rust around the valve hole must be cleaned off. Then install the valve in the rim.

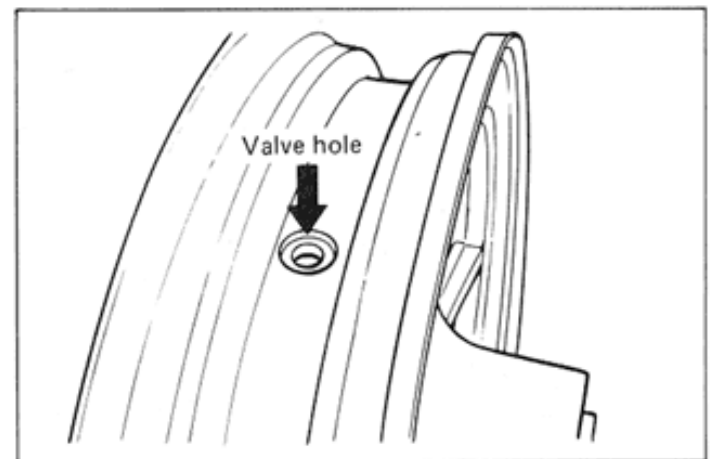

#### CAUTION:

When installing the valve, tighten the nut ① by hand as much as possible. Holding the nut under this condition, tighten the lock nut ②. Do not overtighten nut ① as this may distort the rubber packing and cause an air leak.

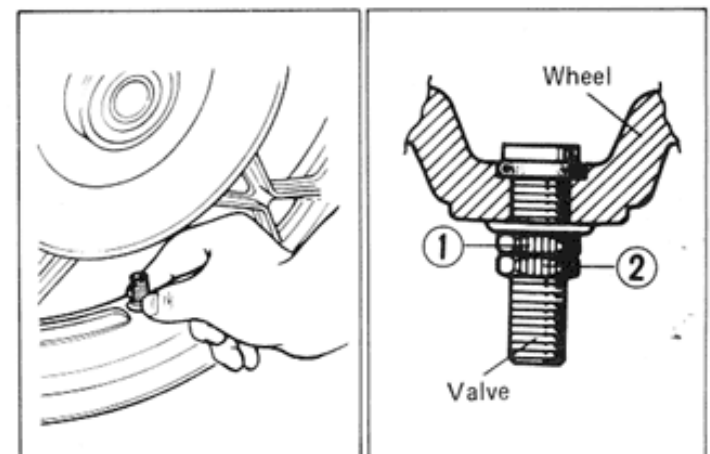

## TIRE MOUNTING

- Apply a special tire lubricant or neutral soapy liquid to the tire bead.

### CAUTION:

Never apply grease, oil or gasoline.

- When installing the tire, make certain that the directional arrow faces the direction of wheel rotation and align the balancing dot of the tire with the valve stem as shown.

- Set the bead pushing roller ①.
- Rotate operation arm around the rim to mount the bead completely. Do the bottom bead first, then the upper bead.
- Remove the wheel from the tire changer, and install the valve core in the valve stem.

### NOTE:

Before installing the valve core, inspect the core.

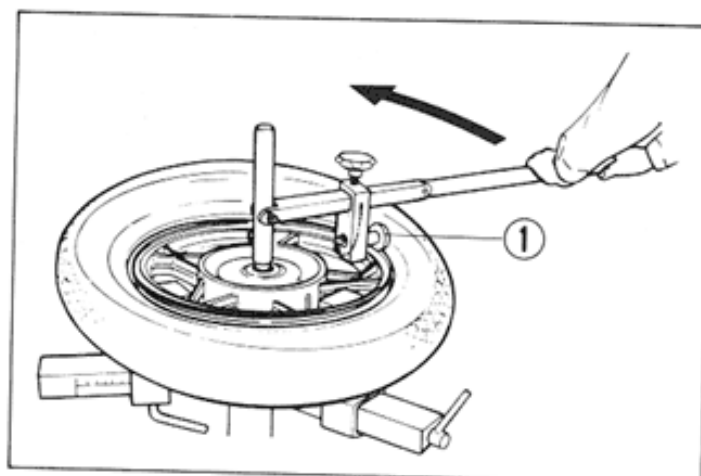
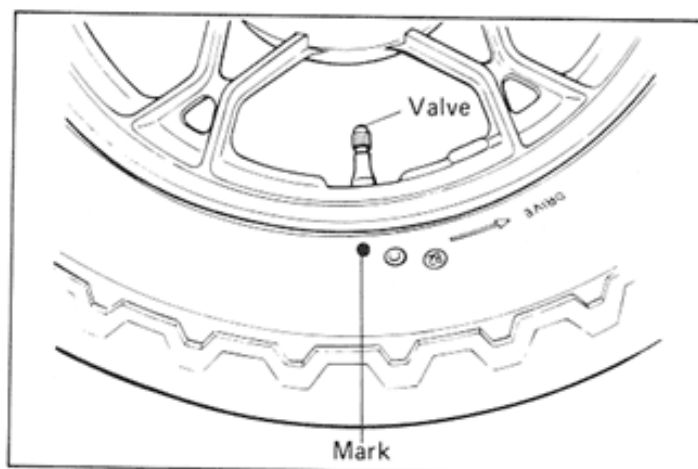
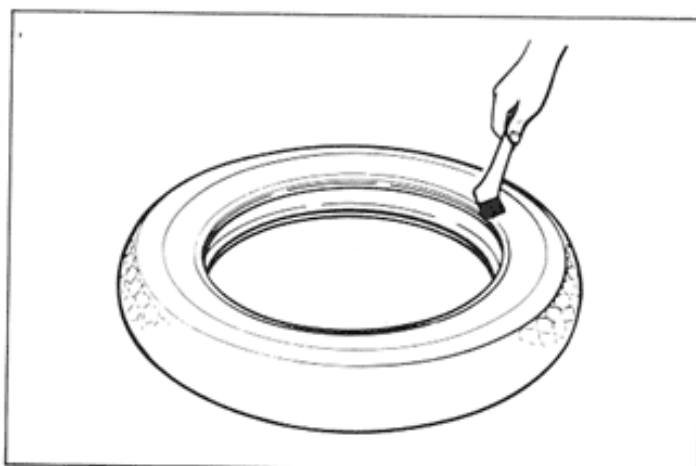

- Bounce the tire several times while rotating. This makes the tire bead expand outwards, and thus makes inflation easier.

**NOTE:**

Before inflating, confirm that the balance mark lines up with the valve stem.

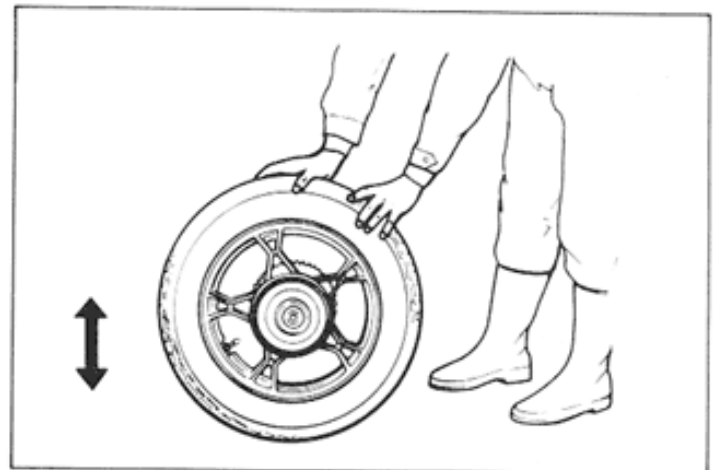

- Pump up the tire with air.

**WARNING:**

Do not inflate the tire to more than 4.0 kg/cm<sup>2</sup> (56 psi). The tire could burst with sufficient force to cause severe injury. Never stand directly over the tire while inflating it.

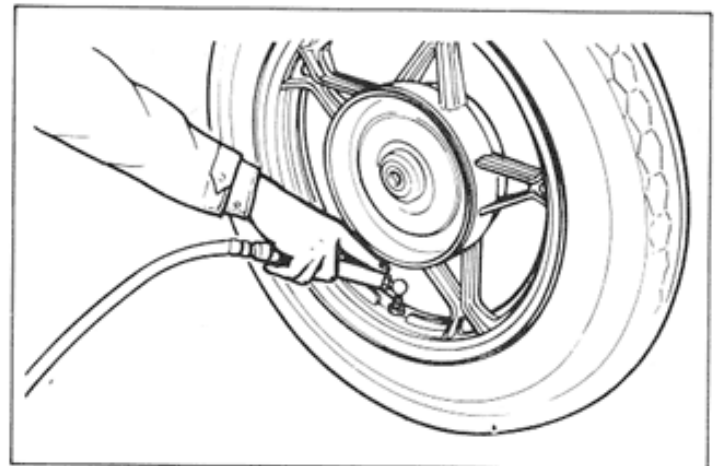

**NOTE:**

Check the "rim line" cast on the tire side walls. It must be equidistant from the wheel rim all the way around. If the distance between the rim line and the wheel rim varies, this indicates that the bead is not properly seated. If this is so, deflate the tire completely, and unseat the bead for the both sides. Coat the bead with lubricant, and try again.

- After tire is properly seated to the wheel rim, adjust the pressure to the recommended pressure. Correct the wheel balance if necessary.

**WARNING:**

Do not run a repaired tire more than 50 km/h (30 mph) within 24 hours after tire repairing, since the patch may not be completely cured. Do not exceed 130 km/h (80 mph) with a repaired tire.

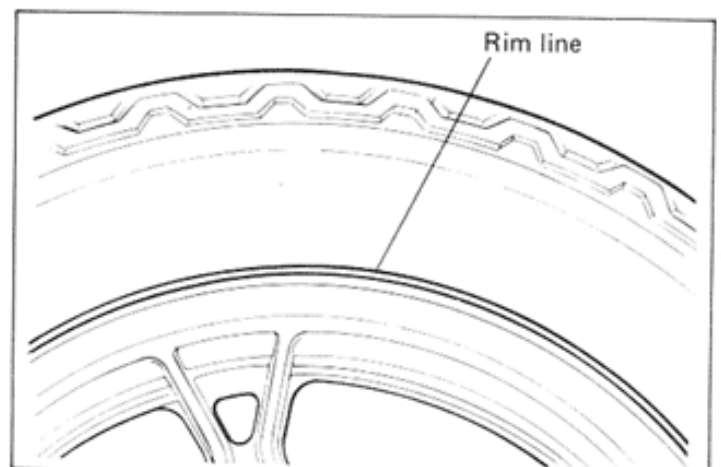

# REAR SWINGARM AND SUSPENSION

## SWINGARM

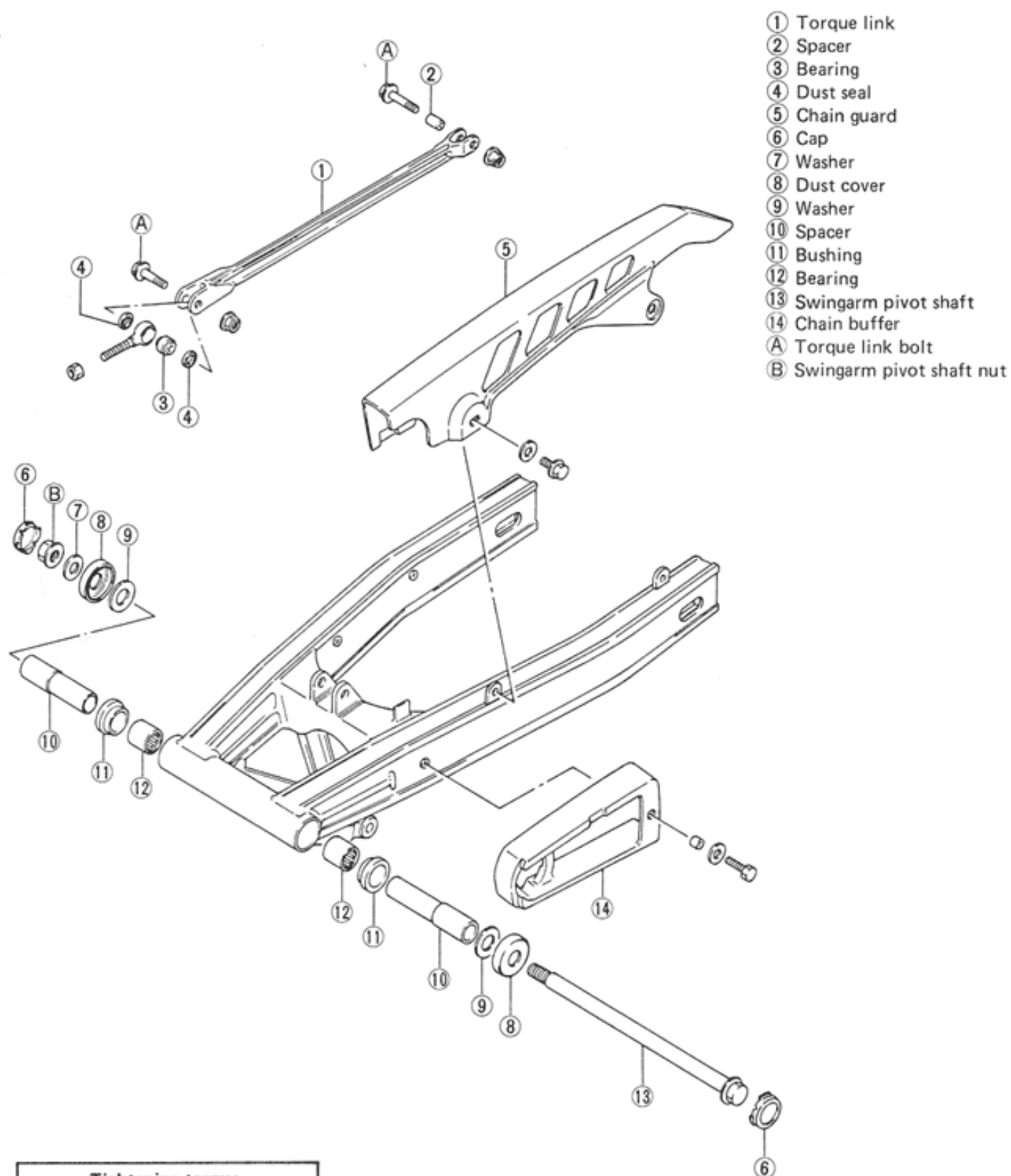

### Tightening torque

Item	N·m	kg·m
A	10 - 15	1.0 - 1.5
B	50 - 80	5.0 - 8.0

## REAR SHOCK ABSORBER

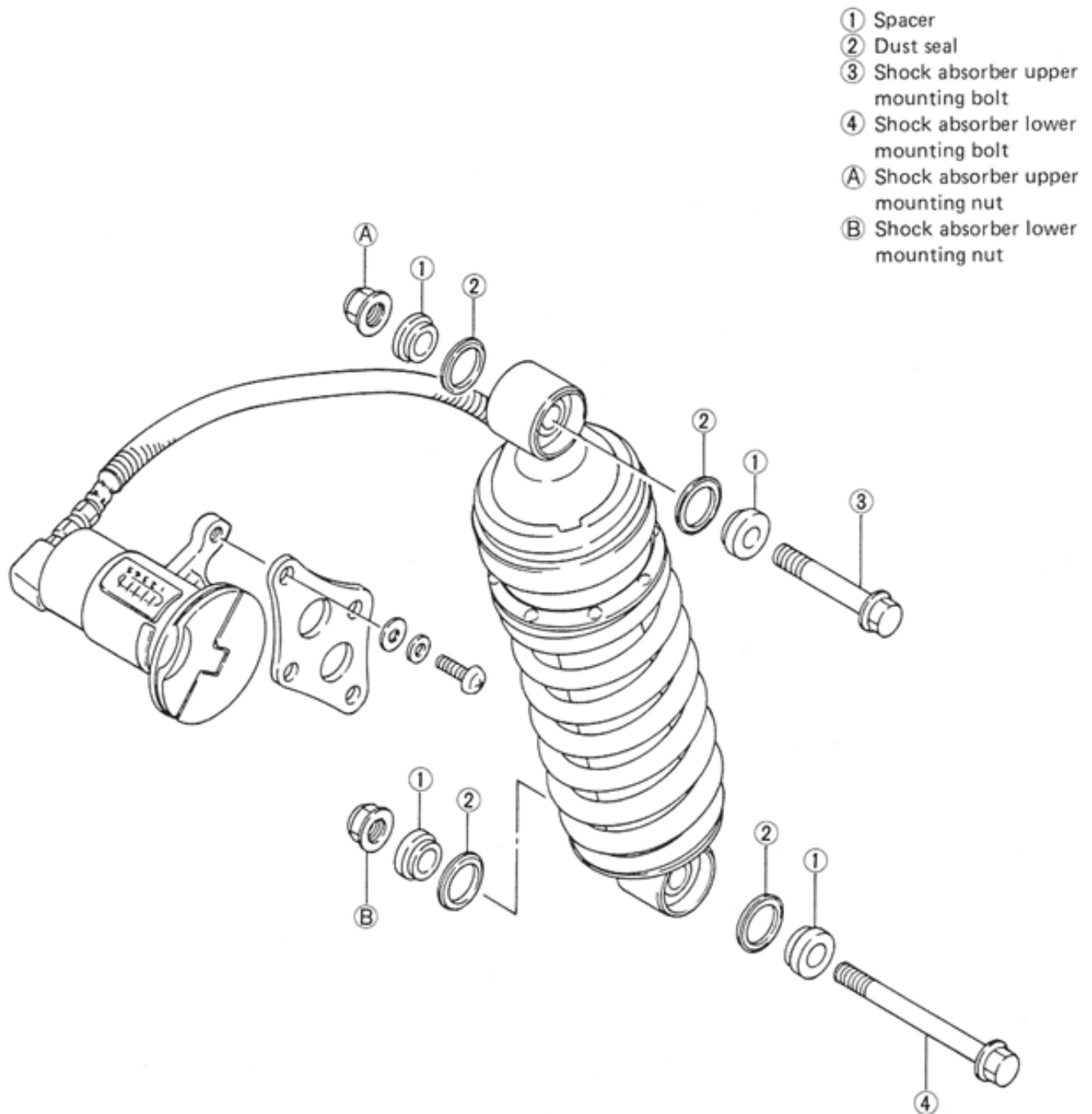

## Tightening torque

Item	N·m	kg·m
Ⓐ	48 - 72	4.8 - 7.2
Ⓑ	48 - 72	4.8 - 7.2

CUSHION LEVER AND CUSHION ROD

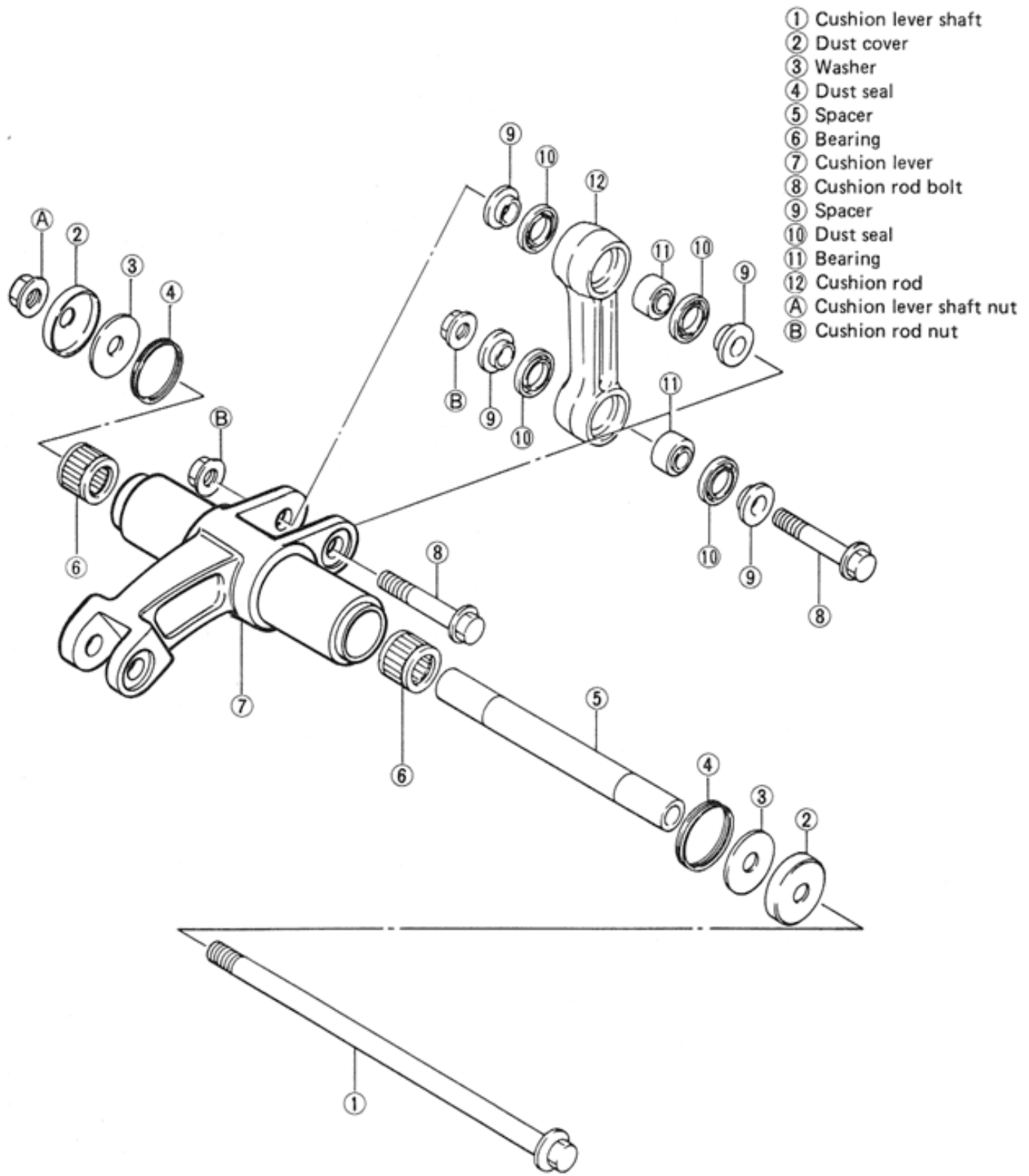

Tightening torque		
Item	N·m	kg·m
A	48 - 72	4.8 - 7.2
B	48 - 72	4.8 - 7.2

## REMOVAL AND DISASSEMBLY

- Remove the seat.
- Remove the middle and lower fairings. (Refer to page 7-1)



- Remove the rear wheel. (Refer to page 7-36)
- Remove the No. 1 and No. 2 mufflers. (Refer to page 3-4)



- Support the motorcycle by wooden block.
- Remove the frame covers.

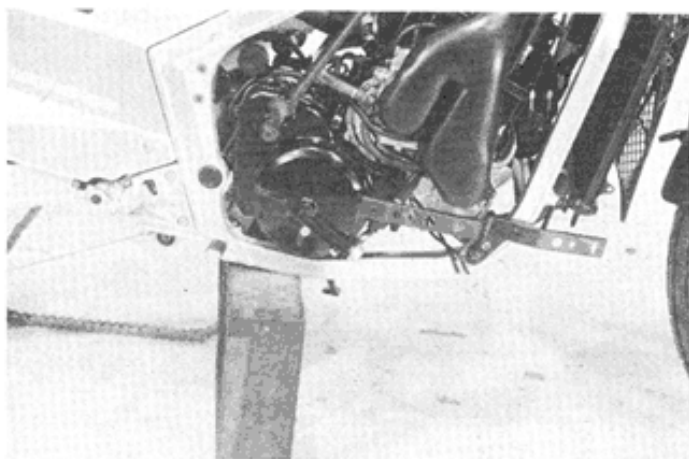

- Remove the torque link.

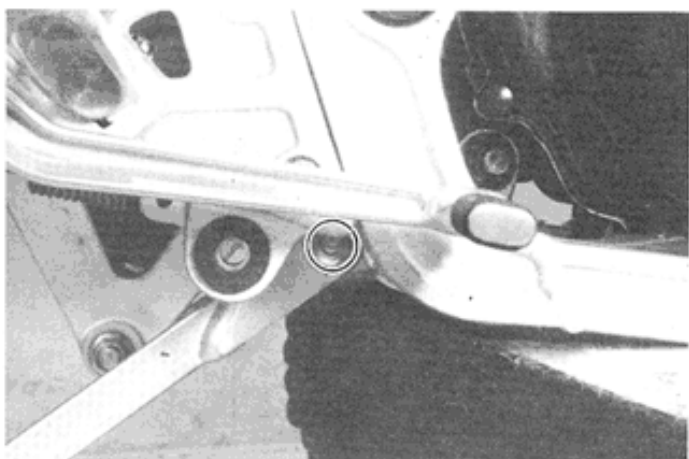

- Remove the rear shock absorber adjuster by loosening two screws.

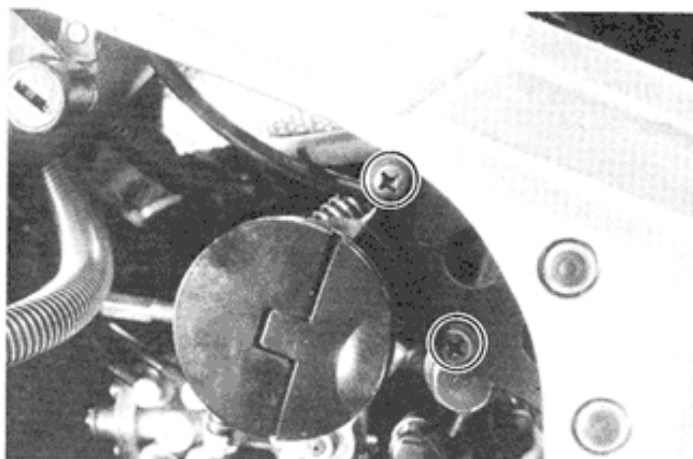

- Loosen the swingarm pivot shaft nut and the cushion lever shaft nut.
- Draw out the shafts to the left side and take off the swingarm assembly.

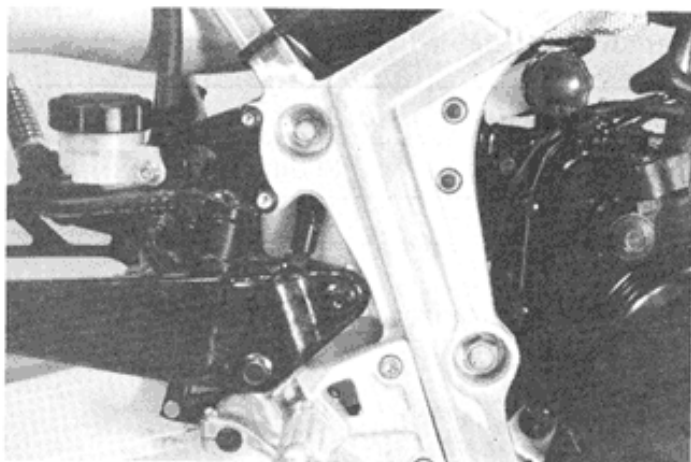

- Remove the chain buffer and chain guard.

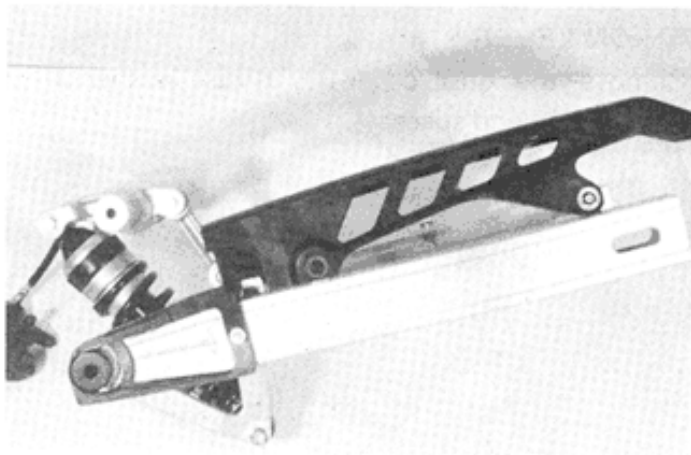

- Loosen and remove the rear shock absorber upper and lower bolts, and remove the rear shock absorber.
- Loosen and remove the cushion rod upper and lower bolts, and remove the cushion lever and cushion rod.

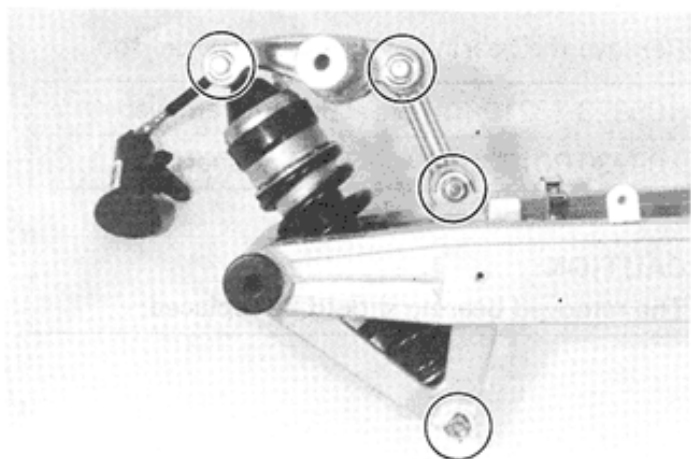

**SWINGARM**

- Remove the dust seal ①, thrust washer ② and spacer ③.

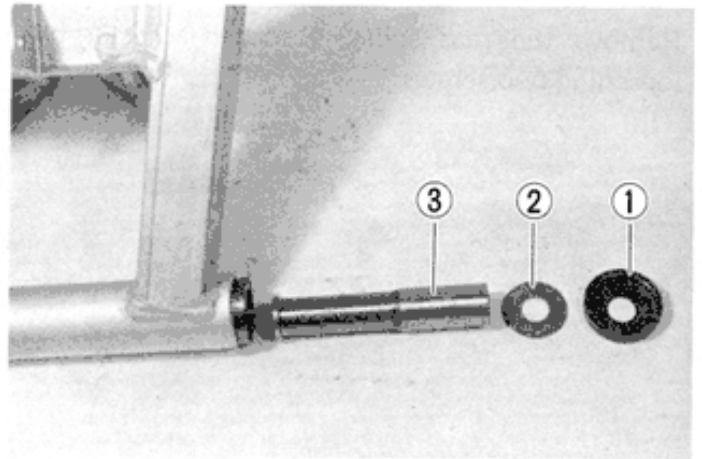

- Remove the bearing by using the special tool.

09923-73210	Bearing remover
09930-30102	Sliding shaft

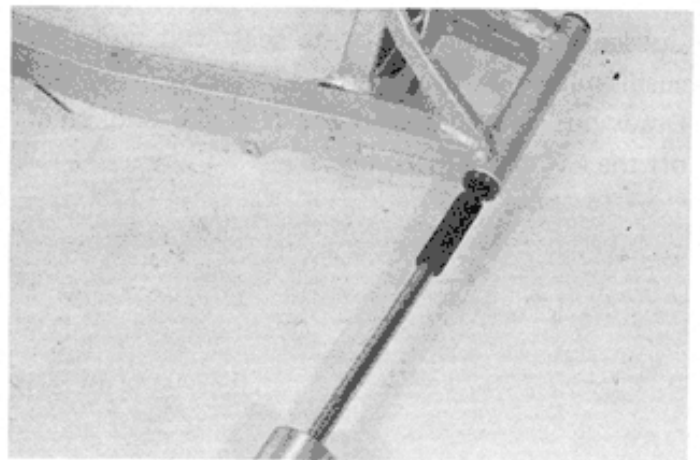
**CAUTION:**

The removed bearing should be replaced.

**CUSHION LEVER**

- Remove the dust cover ①, thrust washer ②, dust seal ③ and spacer ④.

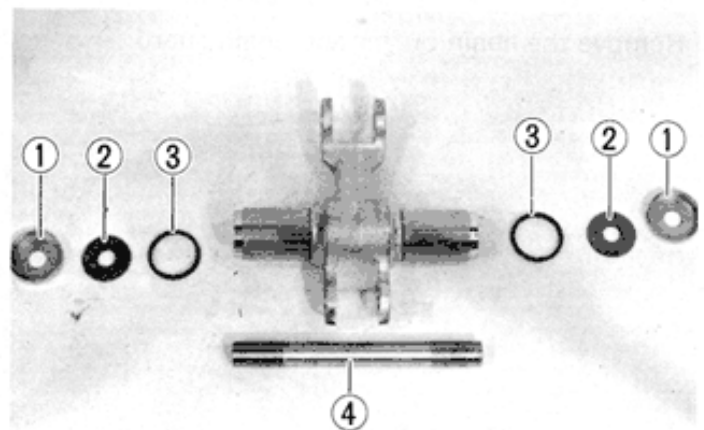

- Remove the bearing by using the special tool.

09923-73210	Bearing remover
09930-30102	Sliding shaft

**CAUTION:**

The removed bearing should be replaced.

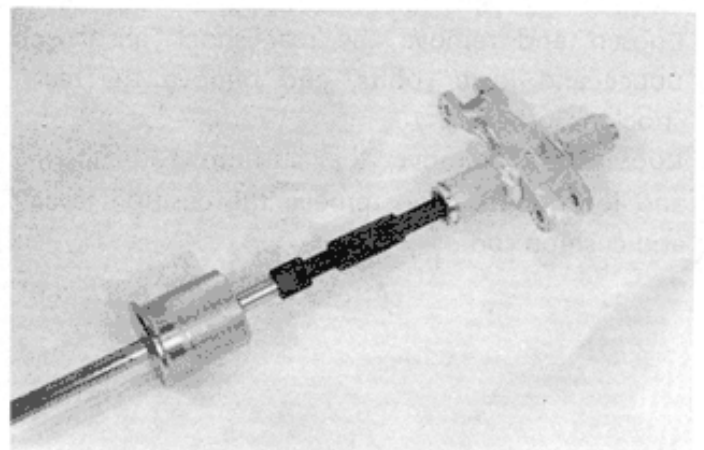

**SHOCK ABSORBER**

- Remove the spacer ① and dust seal ②.

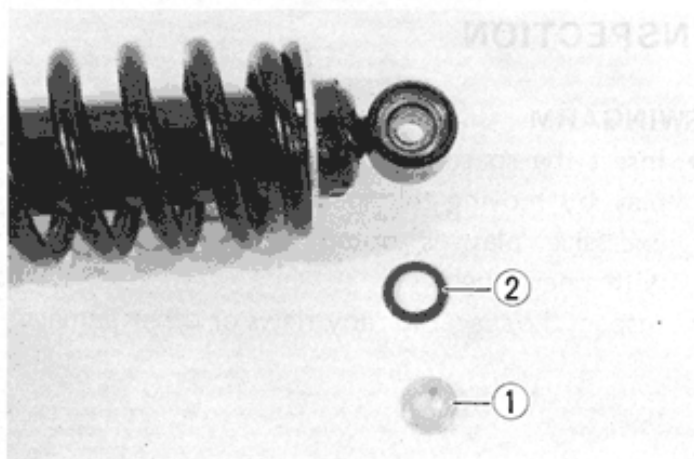

- Remove the bearing stopper ring and draw out the spherical ball bearing by using the appropriate socket.

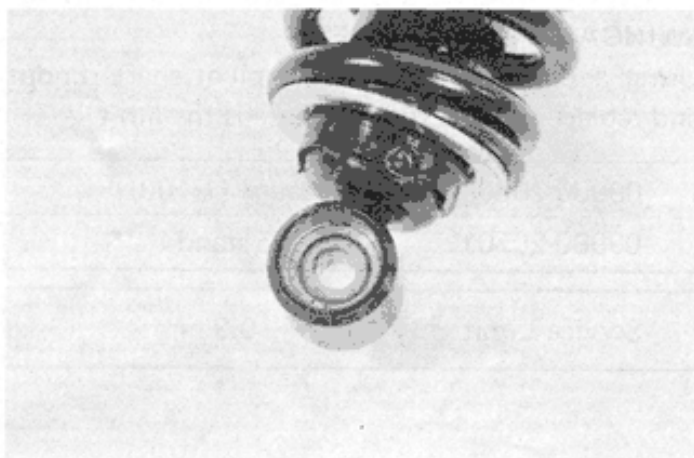
**CAUTION:**

The removed bearing should be replaced.

**CUSHION ROD**

- Remove the spacers and dust seals.

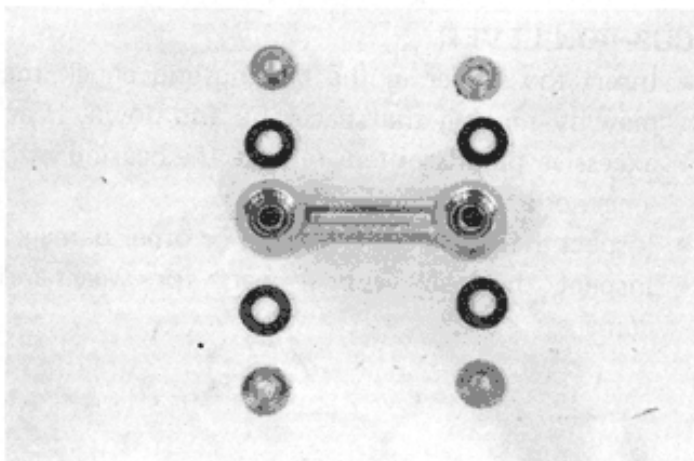
**CALIPER MOUNTING BRACKET**

- Remove the dust seal ① and spacer ②.

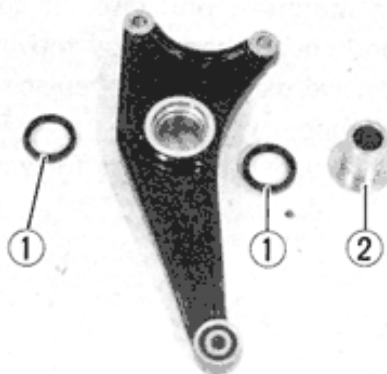

## INSPECTION

### SWINGARM

- Insert the spacer in the bearing and check the play by moving the spacer up and down. If an excessive play is noted, replace the bearing with a new one.
- Inspect the spacer for any flaws or other damage.

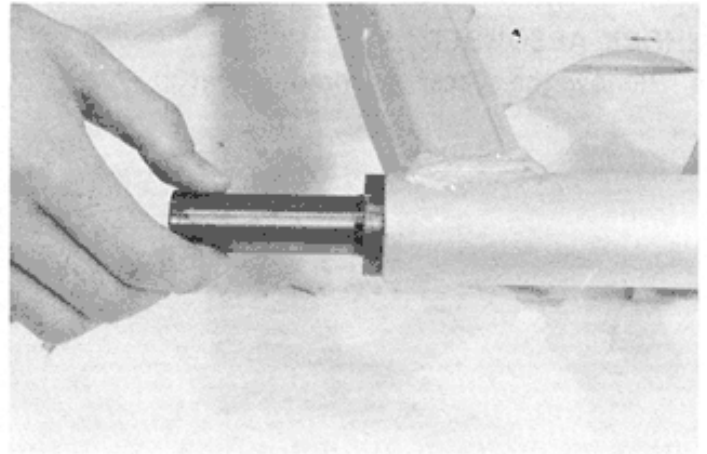

### SWINGARM PIVOT SHAFT

Using a dial gauge, check the pivot shaft runout and replace it if the runout exceeds the limit.

09900-20606	Dial gauge (1/100)
09900-20701	Magnetic stand
Service Limit	0.3 mm

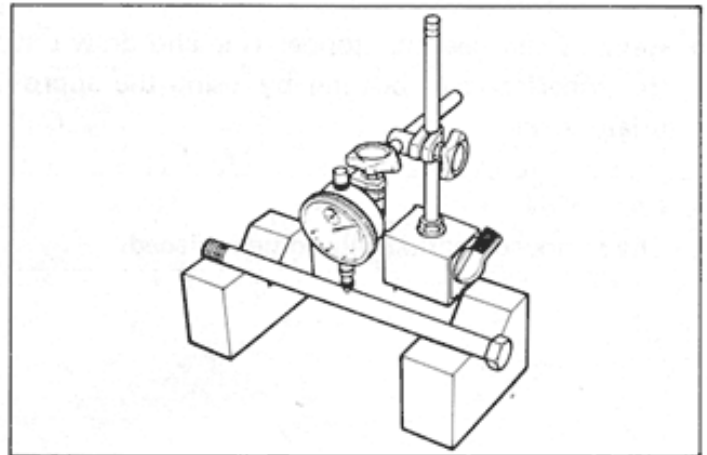

### CUSHION LEVER

- Insert the spacer in the bearing and check the play by moving the spacer up and down. If an excessive play is noted, replace the bearing with a new one.
- Inspect the spacer for any flaws or other damage.
- Inspect the each rubber part for wear and damage.

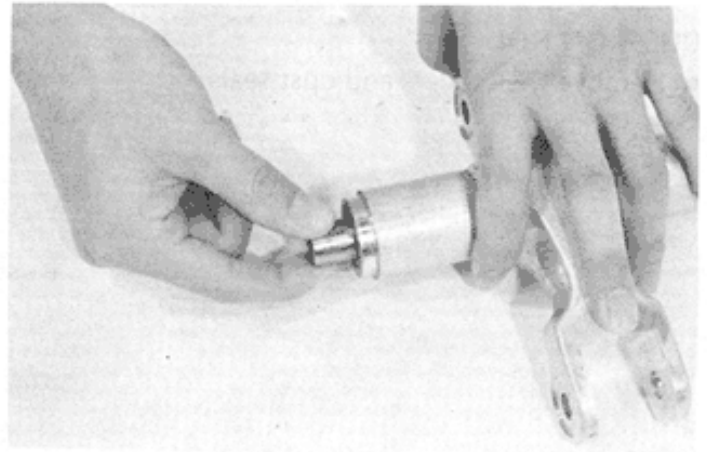

### REAR SHOCK ABSORBER

- Insert the mounting bolt into the spherical ball bearing and check the play by moving the bolt. If an excessive play is noted, replace the bearing with a new one.
- Inspect the each rubber part for wear or other damage.

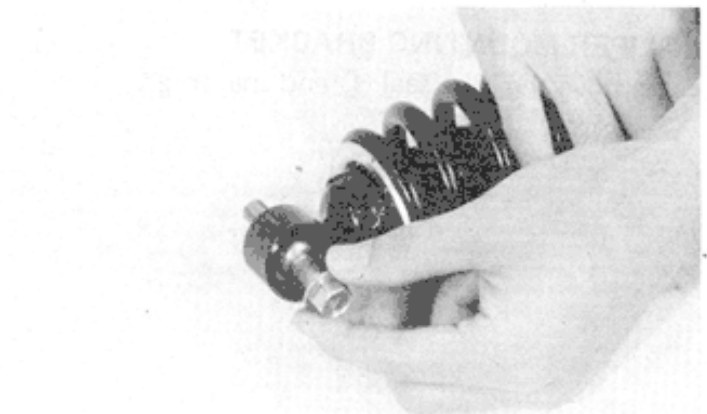

- Inspect the rear shock absorber for any oil leakage by turning the adjuster knob clockwise or counterclockwise. When turning the adjuster knob, check the rear shock absorber for smooth operation.

**CAUTION:**

Do not attempt to disassemble the rear shock absorber unit.

It is not serviceable.

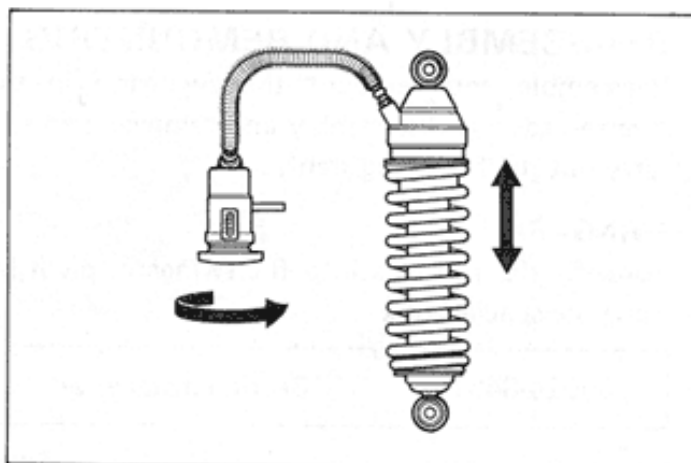
**CUSHION ROD**

- Insert the mounting bolt into the spherical ball bearing and check the play by moving the bolt. If an excessive play is noted, replace the bearing with a new one.
- Inspect the each rubber part for wear or other damage.

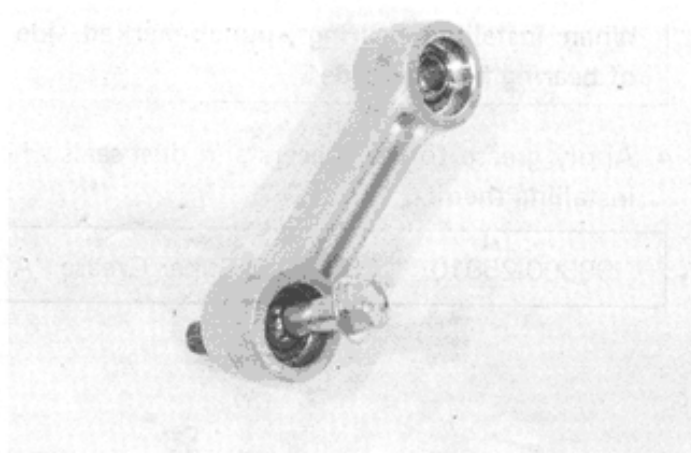
**TORQUE LINK MOUNTING**

- Inspect the torque link mounting for wear or other damage.

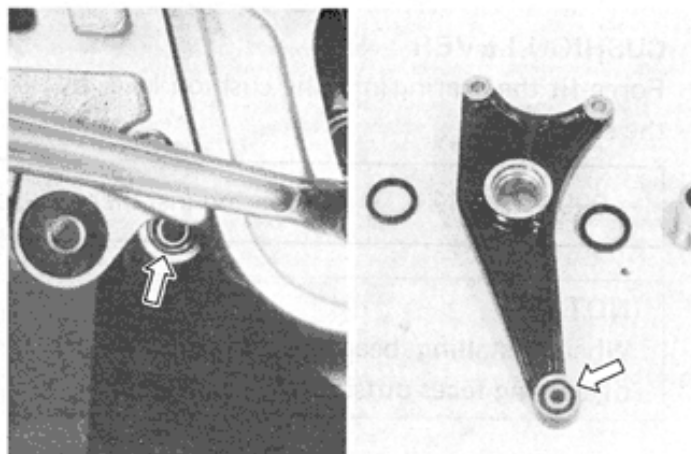

## REASSEMBLY AND REMOUNTING

Reassemble and remount the swingarm in the reverse order of disassembly and removal, and also carry out the following steps.

### SWINGARM

Force-fit the bearings into the swingarm pivot by using the special tool.

09924-84510	Bearing installer set
-------------	-----------------------

#### NOTE:

When installing bearings, punch-marked side of bearing faces outside.

- Apply grease to the spacers and dust seals when installing them.

99000-25010	SUZUKI Super Grease "A"
-------------	-------------------------

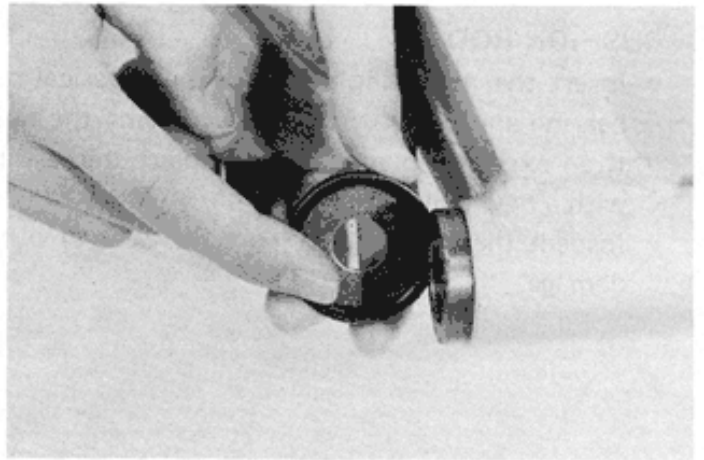
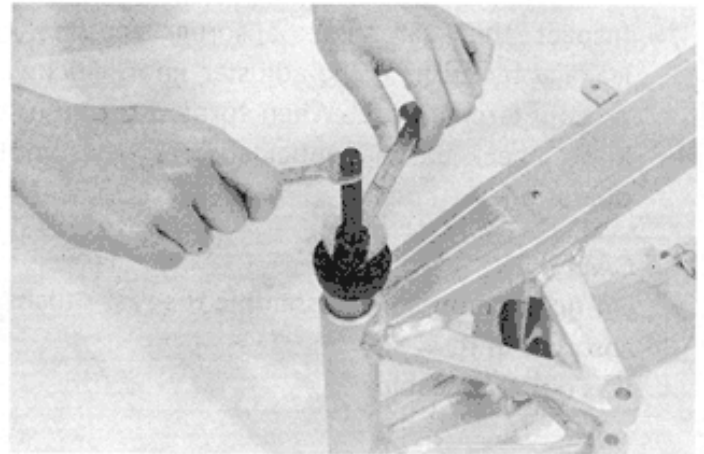

### CUSHION LEVER

Force-fit the bearing into the cushion lever by using the special tool.

09941-34513	Bearing installer set
-------------	-----------------------

#### NOTE:

When installing bearings, punch-marked side of bearing faces outside.

- Apply grease to the spacers and dust seals when installing them.

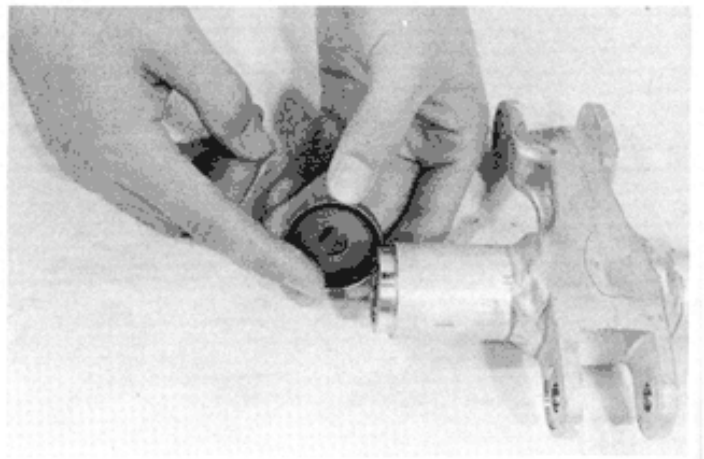
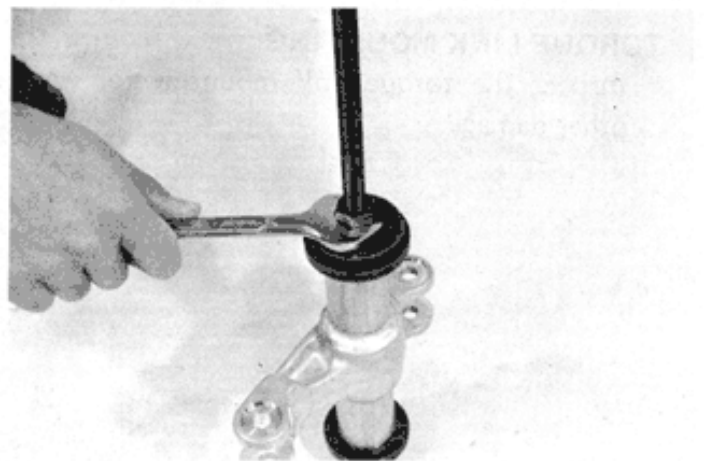

- Reassemble and remount the rear swingarm, rear shock absorber and cushion lever as following the illustration.

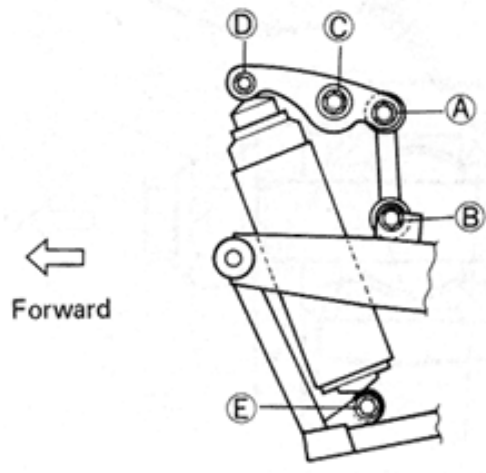
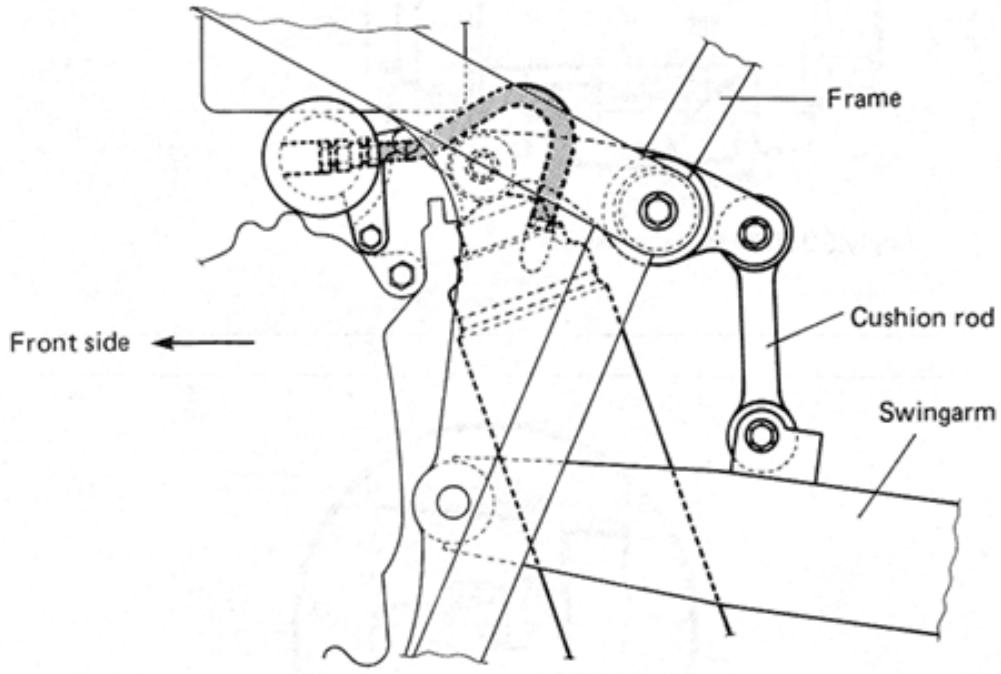
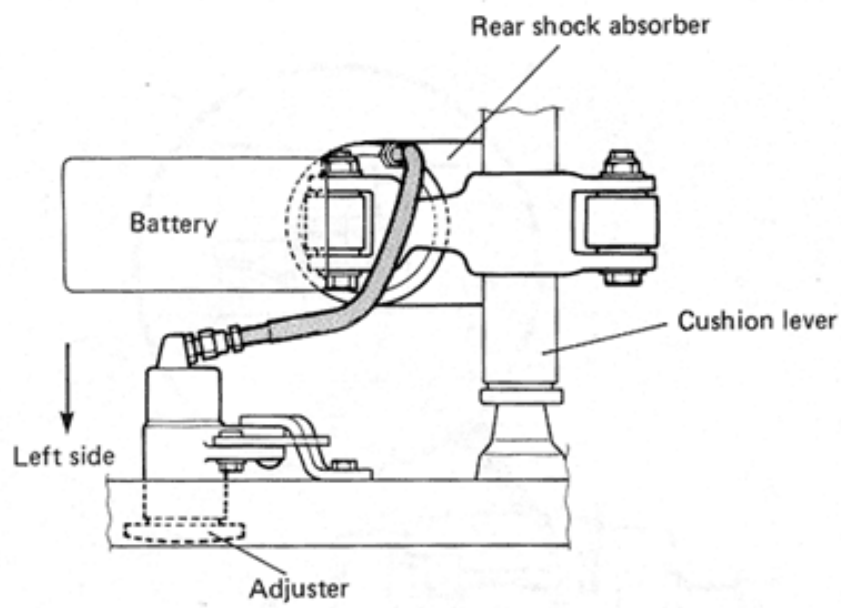

Portion ①

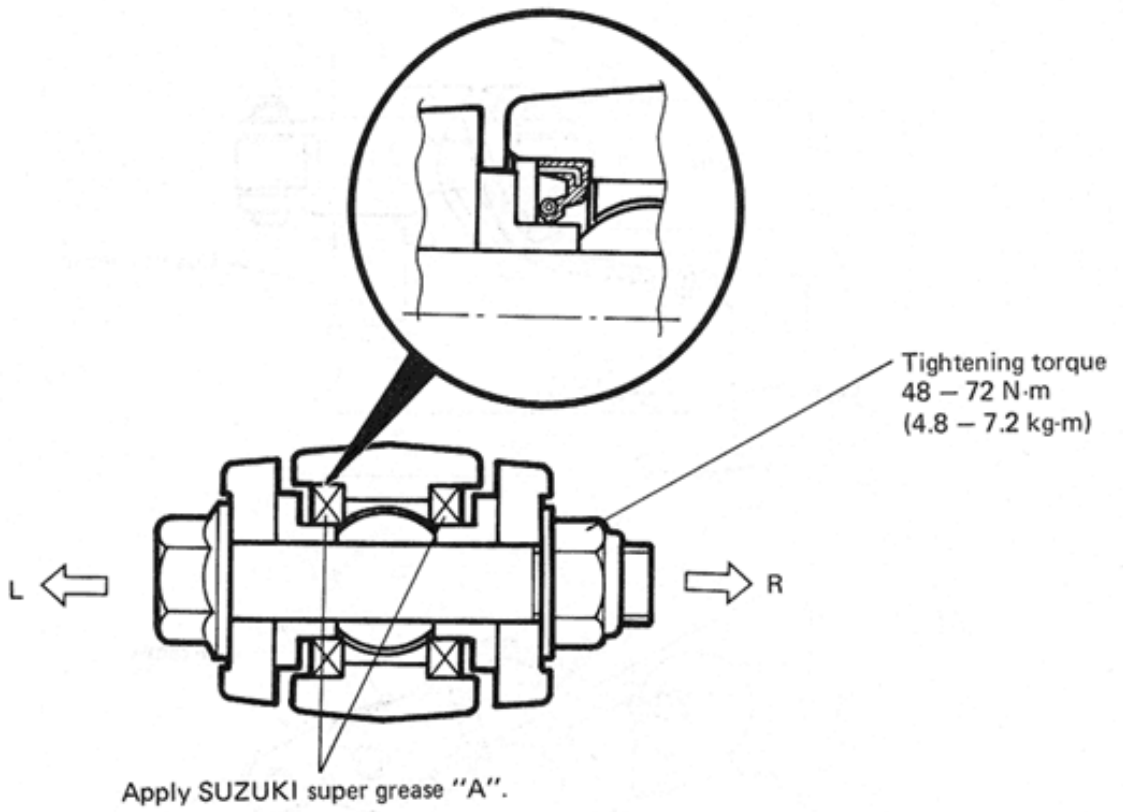

Portion ②

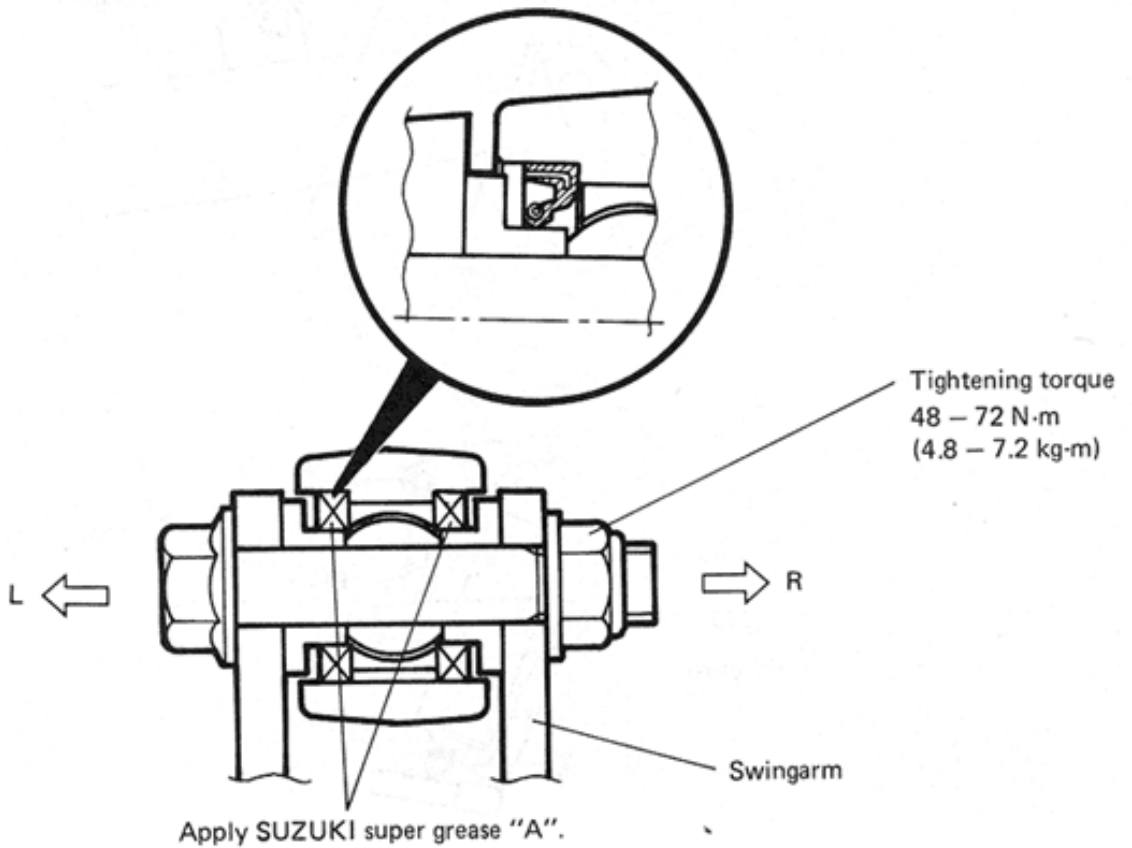

## Portion C

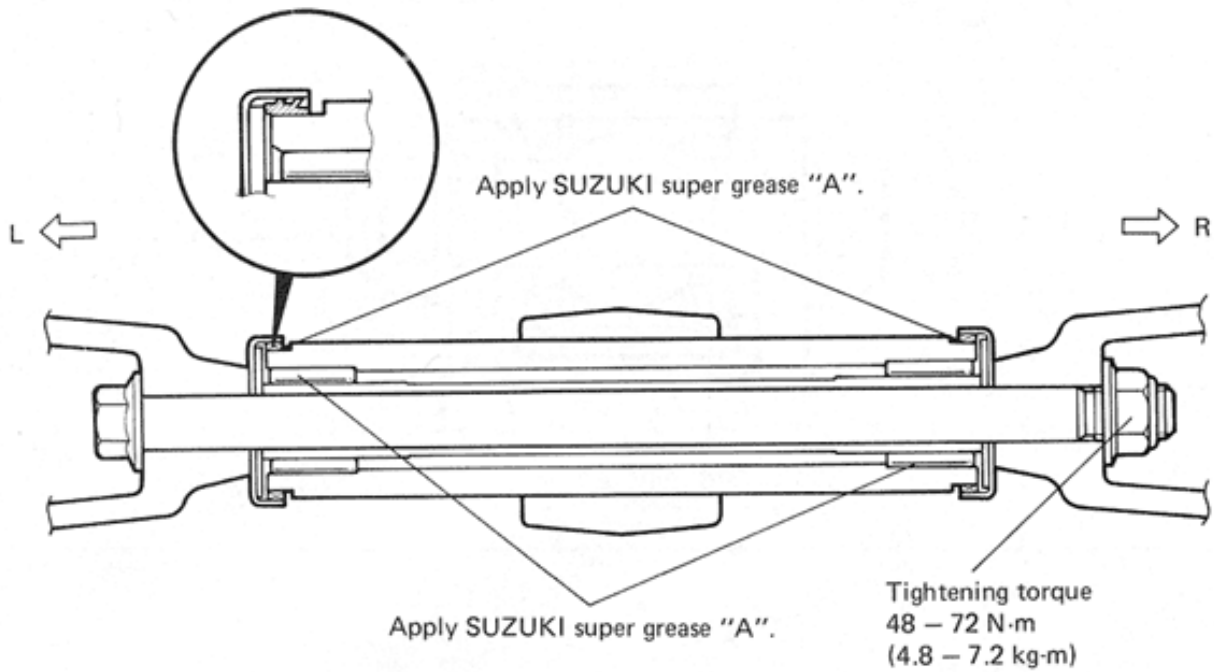

## Portion D

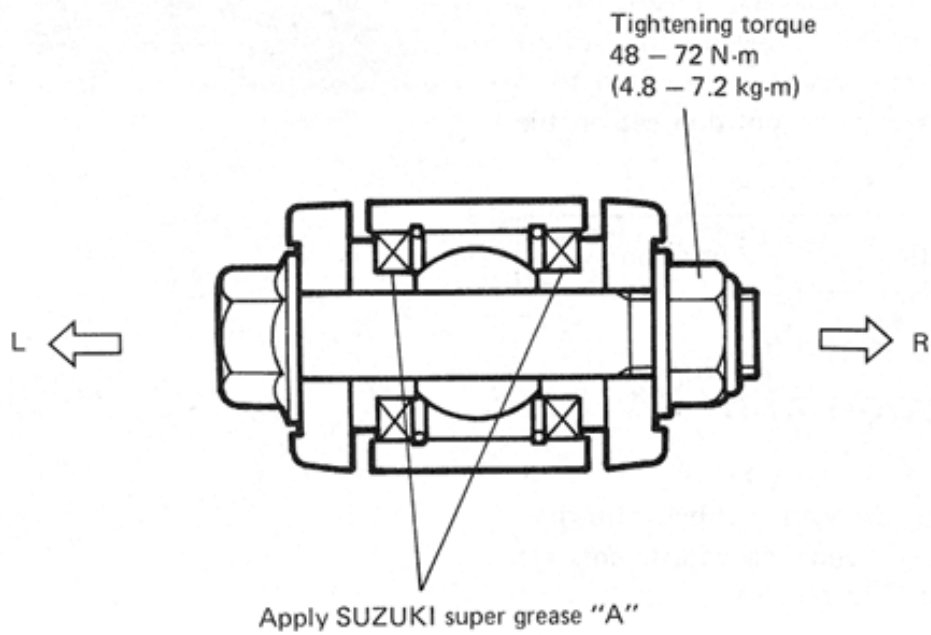

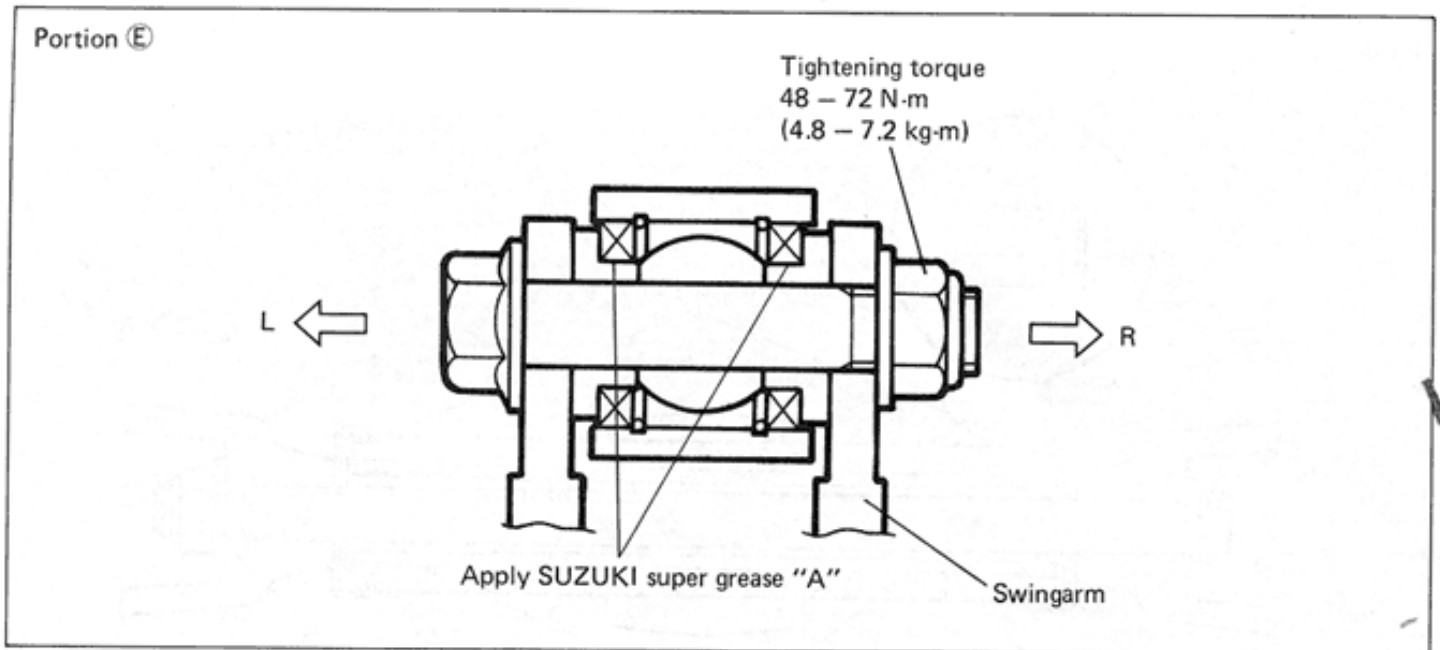

## REAR SUSPENSION

The rear suspension spring pre-load is adjustable to compensate for rider, passenger, load, road conditions and motorcycle speed. The adjustment can be performed by changing the hydraulic spring adjuster position. To change the spring pre-load setting, place the motorcycle on the side stand and turn the hydraulic spring adjuster to the desired position. Position "1" provides the softest spring tension and position "5" provides the stiffest spring tension. This motorcycle is delivered from the factory with its adjuster position set on the "3" position.

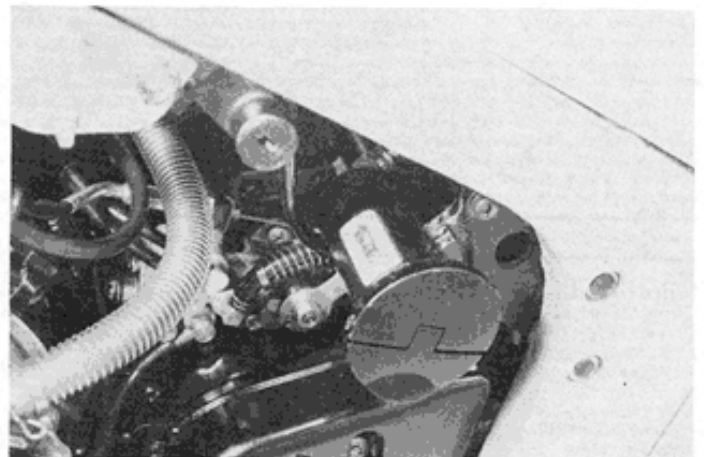

Standard spring setting	3 position
-------------------------	------------

## FINAL INSPECTION AND ADJUSTMENT

After installing rear swingarm, shock absorber, brake and rear wheel, following adjustments are required before driving motorcycle.

- \* Drive chain ..... 2-11
- \* Rear brake ..... 2-12
- \* Tire pressure ..... 2-15
- \* Chassis bolts and nuts ..... 2-17

# SERVICING INFORMATION

## CONTENTS

<i>TROUBLESHOOTING</i> .....	8- 1
<i>WIRING DIAGRAM</i> .....	8- 7
<i>CABLE, HARNESS AND HOSE ROUTING</i> .....	8-12
<i>SPECIAL TOOLS</i> .....	8-18
<i>TIGHTENING TORQUE</i> .....	8-21
<i>SERVICE DATA</i> .....	8-24

# TROUBLESHOOTING

## ENGINE

Complaint	Symptom and possible causes	Remedy
<p><b>Engine will not start, or is hard to start.</b></p>	<p><b>Compression too low</b></p> <ol style="list-style-type: none"> <li>1. Excessively worn cylinder or piston rings.</li> <li>2. Stiff piston ring in place.</li> <li>3. Gas leaks from the joint in crankcase, cylinder or cylinder head.</li> <li>4. Damaged rotary disc valve.</li> <li>5. Spark plug too loose.</li> <li>6. Broken, cracked or otherwise failed piston.</li> <li>7. Worn crankshaft oil seal.</li> </ol> <p><b>Plug not sparking</b></p> <ol style="list-style-type: none"> <li>1. Fouled spark plug.</li> <li>2. Wet spark plug.</li> <li>3. Defective ignition coil.</li> <li>4. Open or short in high-tension cord.</li> <li>5. Defective pick-up coil, primary coil or CDI unit.</li> </ol> <p><b>No fuel reaching the carburetors</b></p> <ol style="list-style-type: none"> <li>1. Clogged hole in the fuel tank cap.</li> <li>2. Clogged or defective fuel cock.</li> <li>3. Defective carburetor needle valve.</li> <li>4. Clogged fuel pipe.</li> </ol>	<p>Replace. Repair or replace. Repair or replace.</p> <p>Replace. Tighten. Replace. Replace.</p> <p>Clean. Clean and dry. Replace. Replace. Replace.</p> <p>Clean. Clean or replace. Replace. Clean.</p>
<p><b>Engine stalls easily.</b></p>	<ol style="list-style-type: none"> <li>1. Fouled spark plug.</li> <li>2. Defective pick-up coil, primary coil or CDI unit.</li> <li>3. Clogged fuel pipe.</li> <li>4. Clogged jets in carburetor.</li> </ol>	<p>Clean. Replace. Replace. Clean.</p>
<p><b>Noisy engine</b></p>	<p><b>Noise appears to come from piston</b></p> <ol style="list-style-type: none"> <li>1. Piston or cylinder worn down.</li> <li>2. Combustion chamber fouled with carbon.</li> <li>3. Piston pin or piston pin bore worn.</li> <li>4. Piston ring groove worn.</li> <li>5. Piston pin bearing worn.</li> </ol> <p><b>Noise seems to come from clutch</b></p> <ol style="list-style-type: none"> <li>1. Worn splines of countershaft or hub.</li> <li>2. Worn teeth of clutch plates.</li> <li>3. Distorted clutch plates, driven and drive.</li> </ol> <p><b>Noise seems to come from crankshaft</b></p> <ol style="list-style-type: none"> <li>1. Rattling bearings due to wear.</li> <li>2. Big-end bearings worn and burnt.</li> <li>3. Crankshaft bearing worn and burnt.</li> <li>4. Weakened damper on the pilot shaft.</li> </ol> <p><b>Noise seems to come from transmission</b></p> <ol style="list-style-type: none"> <li>1. Gears worn or rubbing.</li> <li>2. Badly worn splines.</li> <li>3. Primary gears worn or rubbing.</li> </ol>	<p>Replace. Clean. Replace. Replace. Replace.</p> <p>Replace. Replace. Replace.</p> <p>Replace. Replace. Replace. Replace.</p> <p>Replace. Replace. Replace.</p>
<p><b>Slipping clutch</b></p>	<ol style="list-style-type: none"> <li>1. Clutch control out of adjustment or loss of play.</li> <li>2. Weakened clutch springs.</li> <li>3. Worn or distorted pressure plate.</li> <li>4. Distorted clutch plates, driven and drive.</li> </ol>	<p>Adjust. Replace. Replace. Replace.</p>

Complaint	Symptom and possible causes	Remedy
<b>Dragging clutch</b>	<ol style="list-style-type: none"> <li>1. Clutch control out of adjustment or too much play.</li> <li>2. Some clutch springs weakened while others are not.</li> <li>3. Distorted pressure plate or clutch plates.</li> </ol>	Adjust. Replace. Replace.
<b>Transmission will not shift.</b>	<ol style="list-style-type: none"> <li>1. Broken gearshift cam.</li> <li>2. Distorted gearshift forks.</li> </ol>	Replace. Replace.
<b>Transmission will not shift back</b>	<ol style="list-style-type: none"> <li>1. Broken return spring on shift shaft.</li> <li>2. Shift shafts are rubbing or sticky.</li> </ol>	Replace. Repair or replace.
<b>Transmission jumps out of gear</b>	<ol style="list-style-type: none"> <li>1. Worn shifting gears on drive shaft or countershaft.</li> <li>2. Distorted or worn gearshift forks.</li> <li>3. Weakened stopper spring on gearshift stopper.</li> </ol>	Replace. Replace. Replace.
<b>Engine idles poorly.</b>	<ol style="list-style-type: none"> <li>1. Spark plug gaps too wide.</li> <li>2. Defective ignition coil.</li> <li>3. Defective pick-up coil, primary coil or CDI unit.</li> <li>4. Float-chamber fuel level out of adjustment in carburetor.</li> <li>5. Clogged jets.</li> </ol>	Adjust. Replace. Replace. Adjust.  Clean.
<b>Engine runs poorly in high-speed range.</b>	<ol style="list-style-type: none"> <li>1. Spark plug gaps too narrow.</li> <li>2. Clogged jets.</li> <li>3. Defective ignition coil.</li> <li>4. Defective pick-up coil, primary coil or CDI unit.</li> <li>5. Float-chamber fuel level too low.</li> <li>6. Clogged air cleaner element.</li> <li>7. Clogged fuel pipe, resulting in inadequate fuel supply to carburetor.</li> <li>8. Defective exhaust valve control unit, actuator or exhaust valve.</li> </ol>	Adjust. Clean. Replace. Replace. Adjust. Clean. Clean, and prime.  Replace.
<b>Dirty or heavy exhaust smoke.</b>	<ol style="list-style-type: none"> <li>1. Oil pump out of adjustment.</li> <li>2. Damaged or worn crankshaft oil seal.</li> </ol>	Adjust. Replace.
<b>Engine lacks power.</b>	<ol style="list-style-type: none"> <li>1. Worn piston rings or cylinder.</li> <li>2. Spark plug gaps incorrect.</li> <li>3. Clogged jets in carburetors.</li> <li>4. Float-chamber fuel level out of adjustment.</li> <li>5. Clogged air cleaner element.</li> <li>6. Imbalance of the carburetors.</li> <li>7. Sucking air from intake pipe.</li> <li>8. Supplying too much engine oil.</li> </ol>	Replace. Adjust or replace. Clean. Adjust. Clean. Adjust. Retighten or replace. Adjust oil pump.
<b>Engine overheats.</b>	<ol style="list-style-type: none"> <li>1. Heavy carbon deposit on piston crown.</li> <li>2. Not enough oil supply.</li> <li>3. Defective oil pump or clogged oil circuit.</li> <li>4. Fuel level too low in float chambers.</li> <li>5. Sucking air from intake pipes.</li> <li>6. Using incorrect engine oil.</li> <li>7. Defective cooling system.</li> </ol>	Clean. Adjust oil pump. Replace or clean. Adjust. Retighten or replace. Change. See radiator section.

## CARBURETOR

Complaint	Symptom and possible causes	Remedy
Trouble with starting.	<ol style="list-style-type: none"> <li>1. Starter jet is clogged.</li> <li>2. Starter pipe is clogged.</li> <li>3. Air leaking from a joint between starter body and carburetor.</li> <li>4. Starter plunger is not operating properly.</li> </ol>	Clean. Clean. Check and retighten. Repair.
Idling or low-speed trouble.	<ol style="list-style-type: none"> <li>1. Pilot jet is clogged or loose.</li> <li>2. Air leaking from carburetor's joint hose or starter.</li> <li>3. Pilot outlet or by-pass is clogged.</li> <li>4. Starter plunger is not fully closed.</li> <li>5. Imbalance of carburetors.</li> </ol>	Check and clean. Check. Check and clean. Check and adjust. Balance the carburetors.
Medium- or high-speed trouble.	<ol style="list-style-type: none"> <li>1. Main jet is clogged.</li> <li>2. Needle jet is clogged.</li> <li>3. Throttle valve is not operating properly.</li> <li>4. Filter is clogged.</li> </ol>	Check and clean. Check and clean. Check throttle valve for operation. Check and clean.
Overflow and fuel level fluctuations.	<ol style="list-style-type: none"> <li>1. Needle valve is worn or damaged.</li> <li>2. Float is not working properly.</li> <li>3. Foreign matter has adhered to needle valve.</li> <li>4. Fuel level is too high or low.</li> <li>5. Clogged carburetor air vent pipe.</li> <li>6. Spring in needle valve is broken.</li> </ol>	Replace. Check and adjust. Clean. Adjust float height. Clean. Replace.

## RADIATOR

Complaint	Symptom and possible causes	Remedy
Engine overheats.	<ol style="list-style-type: none"> <li>1. Not enough cooling water.</li> <li>2. Radiator core is clogged with dirt or trashes.</li> <li>3. Erratic thermostat, stuck in closed position.</li> <li>4. Clogged water passage.</li> <li>5. Air trapped in the cooling circuit.</li> <li>6. Defective water pump.</li> <li>7. Incorrect cooling water used.</li> </ol>	Add. Clean. Replace. Clean. Bleed out air. Replace. Change.
Engine overcools.	<ol style="list-style-type: none"> <li>1. Erratic thermostat, stuck in full-open position.</li> <li>2. Extremely cold weather.</li> </ol>	Replace. Put on the radiator cover.

## ELECTRICAL

Complaint	Symptom and possible causes	Remedy
No sparking or poor sparking.	<ol style="list-style-type: none"> <li>1. Defective ignition coil.</li> <li>2. Defective spark plugs.</li> <li>3. Defective pick-up coil, primary coil or CDI unit.</li> </ol>	Replace. Replace. Replace.
Spark plugs soon become fouled with carbon.	<ol style="list-style-type: none"> <li>1. Mixture too rich.</li> <li>2. Idling speed set too high.</li> <li>3. Incorrect gasoline.</li> <li>4. Dirty element in air cleaner.</li> <li>5. Spark plugs too cold.</li> </ol>	Adjust carburetor. Adjust carburetor. Change. Clean. Replace by hot type plug.
Spark plugs become fouled too soon.	<ol style="list-style-type: none"> <li>1. Worn piston rings.</li> <li>2. Piston or cylinder worn.</li> </ol>	Replace. Replace.
Spark plug electrodes overheat or burn.	<ol style="list-style-type: none"> <li>1. Spark plug too hot.</li> <li>2. The engine overheats.</li> <li>3. Spark plug loose.</li> <li>4. Mixture too lean.</li> </ol>	Replace by cold type plug. Tune up. Retighten. Adjust carburetors.
Generator does not charge.	<ol style="list-style-type: none"> <li>1. Open or short in lead wires, or loose lead connections.</li> <li>2. Shorted, grounded or open generator coils.</li> <li>3. Shorted or punctured regulator/rectifier.</li> </ol>	Repair or replace or retighten. Replace. Replace.
Generator charges, but charging rate is below the specification.	<ol style="list-style-type: none"> <li>1. Lead wires tend to get shorted or open-circuited or loosely connected at terminals.</li> <li>2. Grounded or open-circuited stator coils of generator.</li> <li>3. Defective regulator/rectifier.</li> <li>4. Defective battery.</li> </ol>	Repair, or retighten.  Replace.  Replace. Replace.
Generator overcharges.	<ol style="list-style-type: none"> <li>1. Internal short-circuit in the battery.</li> <li>2. Resistor element in the regulator/rectifier damaged or defective.</li> <li>3. Regulator/rectifier poorly grounded.</li> </ol>	Replace the battery. Replace.  Clean and tighten ground connection.
Unstable charging.	<ol style="list-style-type: none"> <li>1. Lead wire insulation frayed due to vibration, resulting in intermittent shorting.</li> <li>2. Generator internally shorted.</li> <li>3. Defective regulator/rectifier.</li> </ol>	Repair or replace.  Replace. Replace.

**BATTERY**

Complaint	Symptom and possible causes	Remedy
Battery runs down quickly.	<ol style="list-style-type: none"> <li>1. The charging method is not correct.</li> <li>2. Cell plates have lost much of their active material as a result of over-charging.</li> <li>3. A short-circuit condition exists within the battery due to excessive accumulation of sediments caused by the incorrect electrolyte.</li> <li>4. Battery is too old.</li> </ol>	<p>Check the generator, regulator/rectifier and circuit connections, and make necessary adjustments to obtain specified charging operation.</p> <p>Replace the battery, and correct the charging system.</p> <p>Replace the battery.</p> <p>Replace the battery.</p>
Reversed battery polarity.	The battery has been connected the wrong way round in the system, so that it is being charged in the reverse direction.	Replace the battery and be sure to connect the battery properly.
Battery discharges too rapidly.	<ol style="list-style-type: none"> <li>1. Dirty container top and sides.</li> <li>2. Battery is too old.</li> </ol>	<p>Clean.</p> <p>Replace.</p>

**BRAKES**

Complaint	Symptom and possible causes	Remedy
Insufficient brake power.	<ol style="list-style-type: none"> <li>1. Leakage of brake fluid from hydraulic system.</li> <li>2. Worn pads.</li> <li>3. Oil adhesion on engaging surface of pads.</li> <li>4. Worn disc.</li> <li>5. Air in hydraulic system.</li> </ol>	<p>Repair or replace.</p> <p>Replace.</p> <p>Clean disc and pads.</p> <p>Replace.</p> <p>Bleed air.</p>
Brake squeaking.	<ol style="list-style-type: none"> <li>1. Carbon adhesion on pad surface.</li> <li>2. Tilted pad.</li> <li>3. Damaged wheel bearing.</li> <li>4. Loose front-wheel axle or rear-wheel axle.</li> <li>5. Worn pads.</li> <li>6. Foreign material in brake fluid.</li> <li>7. Clogged return port of master cylinder.</li> </ol>	<p>Repair surface with sandpaper.</p> <p>Modify pad fitting.</p> <p>Replace.</p> <p>Tighten to specified torque.</p> <p>Replace.</p> <p>Replace brake fluid.</p> <p>Disassemble and clean master cylinder.</p>
Excessive brake lever stroke.	<ol style="list-style-type: none"> <li>1. Air in hydraulic system.</li> <li>2. Insufficient brake fluid.</li> <li>3. Improper quality of brake fluid.</li> </ol>	<p>Bleed air.</p> <p>Replenish fluid to specified level; bleed air.</p> <p>Replace with correct fluid.</p>
Leakage of brake fluid.	<ol style="list-style-type: none"> <li>1. Insufficient tightening of connection joints.</li> <li>2. Cracked hose.</li> <li>3. Worn piston and/or cup.</li> </ol>	<p>Tighten to specified torque</p> <p>Replace.</p> <p>Replace piston and/or cup.</p>

## CHASSIS

Complaint	Symptom and possible causes	Remedy
Heavy steering.	<ol style="list-style-type: none"> <li>1. Steering stem nut overtightened.</li> <li>2. Broken bearing in steering stem.</li> <li>3. Distorted steering stem.</li> <li>4. Not enough pressure in tires.</li> </ol>	Adjust. Replace. Replace. Adjust.
Wobbly handle.	<ol style="list-style-type: none"> <li>1. Loss of balance between right and left front forks.</li> <li>2. Distorted front fork.</li> <li>3. Distorted front axle or crooked tire.</li> <li>4. Incorrect front fork air pressure.</li> </ol>	Adjust. Replace. Replace. Adjust.
Wobbly front wheel.	<ol style="list-style-type: none"> <li>1. Distorted wheel rim.</li> <li>2. Worn-down front wheel bearings.</li> <li>3. Defective or incorrect tire.</li> <li>4. Loose nut on axle.</li> <li>5. Incorrect front fork oil or air pressure.</li> </ol>	Replace. Replace. Replace. Retighten. Adjust.
Front suspension too soft.	<ol style="list-style-type: none"> <li>1. Weakened springs.</li> <li>2. Not enough fork oil.</li> </ol>	Replace. Refill.
Front suspension too stiff.	<ol style="list-style-type: none"> <li>1. Fork oil too viscous.</li> <li>2. Too much fork oil.</li> <li>3. Incorrect air pressure in front fork.</li> </ol>	Replace. Drain excess oil. Adjust.
Noisy front suspension.	<ol style="list-style-type: none"> <li>1. Not enough fork oil.</li> <li>2. Loose nuts on suspension.</li> </ol>	Refill. Retighten.
Wobbly rear wheel.	<ol style="list-style-type: none"> <li>1. Distorted wheel rim.</li> <li>2. Worn-down rear wheel bearings or swingarm bearings.</li> <li>3. Defective or incorrect tire.</li> <li>4. Worn swingarm and rear cushion related bearings.</li> <li>5. Loose nuts or bolts on rear suspension.</li> </ol>	Replace. Replace.  Replace. Replace. Retighten.
Rear suspension too soft.	<ol style="list-style-type: none"> <li>1. Weakened shock absorber spring.</li> <li>2. Rear suspension adjuster improperly set.</li> <li>3. Oil leakage of shock absorber.</li> </ol>	Replace. Adjust. Replace.
Rear suspension too stiff.	<ol style="list-style-type: none"> <li>1. Rear suspension adjuster improperly set.</li> <li>2. Shock absorber shaft bent.</li> <li>3. Swingarm bent.</li> <li>4. Worn swingarm and rear cushion related bearings.</li> </ol>	Adjust. Replace. Replace. Replace.
Noisy rear suspension.	<ol style="list-style-type: none"> <li>1. Loose nuts or bolts on rear suspension.</li> <li>2. Worn swingarm and rear cushion related bearings.</li> </ol>	Retighten. Replace.

# WIRING DIAGRAM

(E-01,06,24)

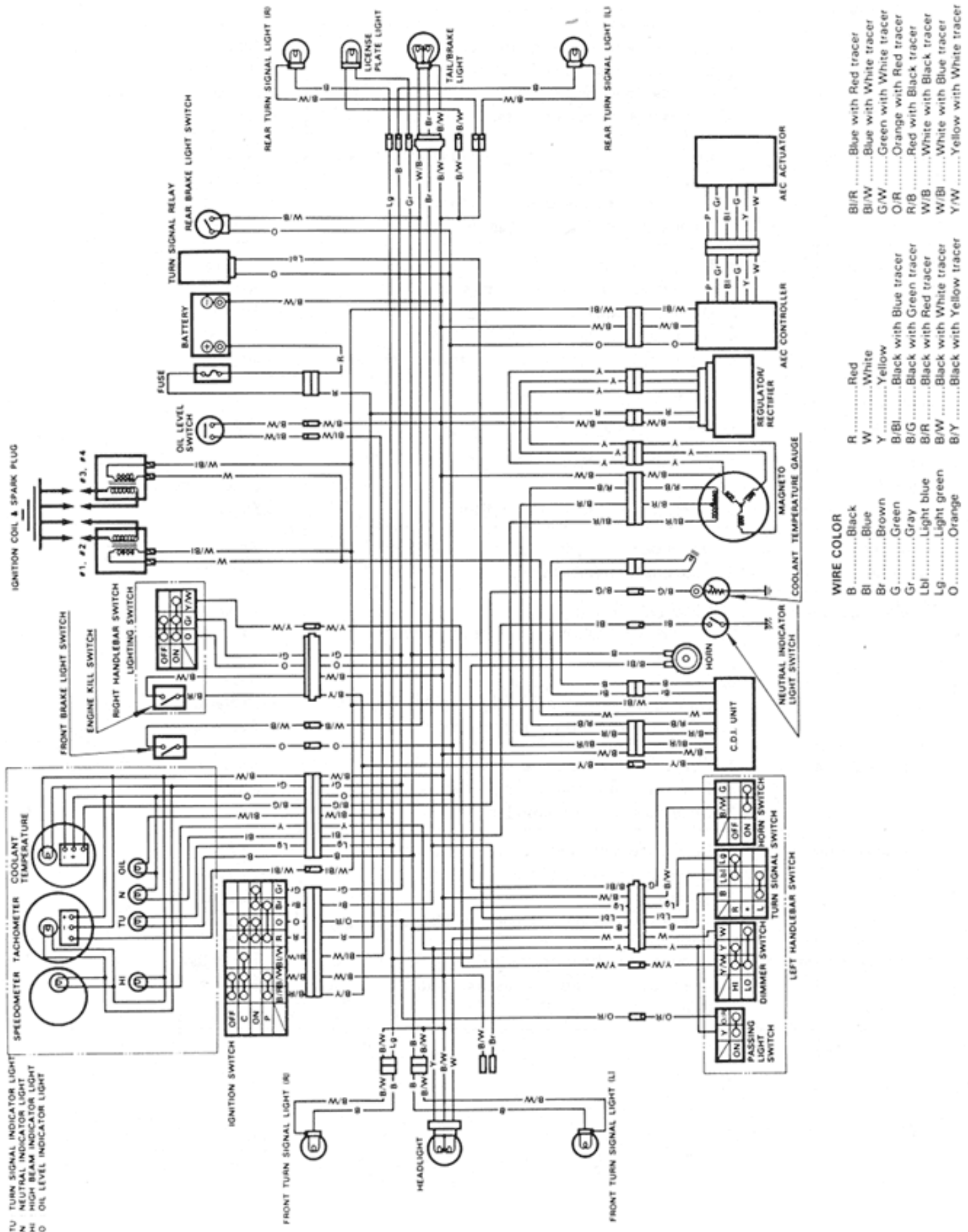

TU Turn signal indicator light  
 N Neutral indicator light  
 HI High beam indicator light  
 O Oil level indicator light

**WIRE COLOR**  
 B.....Black  
 Bl.....Blue  
 Br.....Brown  
 G.....Green  
 Gr.....Gray  
 Lbl.....Light blue  
 Lg.....Light green  
 O.....Orange

Bl/R.....Blue with Red tracer  
 Bl/W.....Blue with White tracer  
 G/W.....Green with White tracer  
 O/R.....Orange with Red tracer  
 R/B.....Red with Black tracer  
 W/B.....White with Black tracer  
 W/W.....White with White tracer  
 Y/W.....Yellow with White tracer

R.....Red  
 W.....White  
 Y.....Yellow  
 B/Bl.....Black with Blue tracer  
 B/G.....Black with Green tracer  
 B/R.....Black with Red tracer  
 B/W.....Black with White tracer  
 B/Y.....Black with Yellow tracer

(E-15)

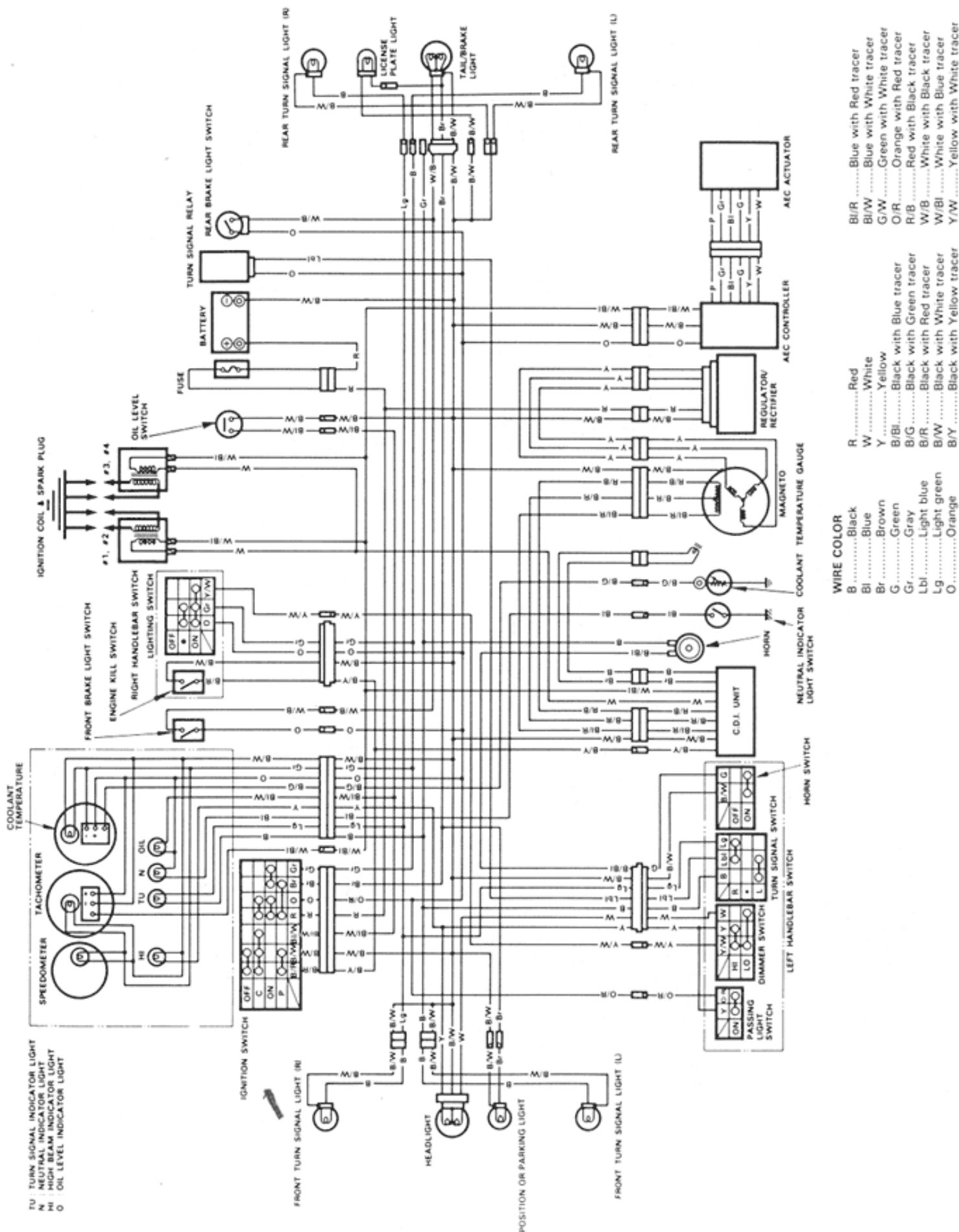

TU Turn signal indicator light  
 N Neutral indicator light  
 HI High beam indicator light  
 O Oil level indicator light

**WIRE COLOR**  
 B ..... Black  
 Bl ..... Blue  
 Br ..... Brown  
 G ..... Green  
 Gr ..... Gray  
 Lbl ..... Light blue  
 Lg ..... Light green  
 O ..... Orange

Bl/R ..... Blue with Red tracer  
 Bl/W ..... Blue with White tracer  
 G/W ..... Green with White tracer  
 O/R ..... Orange with Red tracer  
 R/B ..... Red with Black tracer  
 W/B ..... White with Black tracer  
 W/Bl ..... White with Blue tracer  
 Y/W ..... Yellow with White tracer

R ..... Red  
 W ..... White  
 Y ..... Yellow  
 B/Bl ..... Black with Blue tracer  
 B/G ..... Black with Green tracer  
 B/R ..... Black with Red tracer  
 B/W ..... Black with White tracer  
 B/Y ..... Black with Yellow tracer



(E-28)

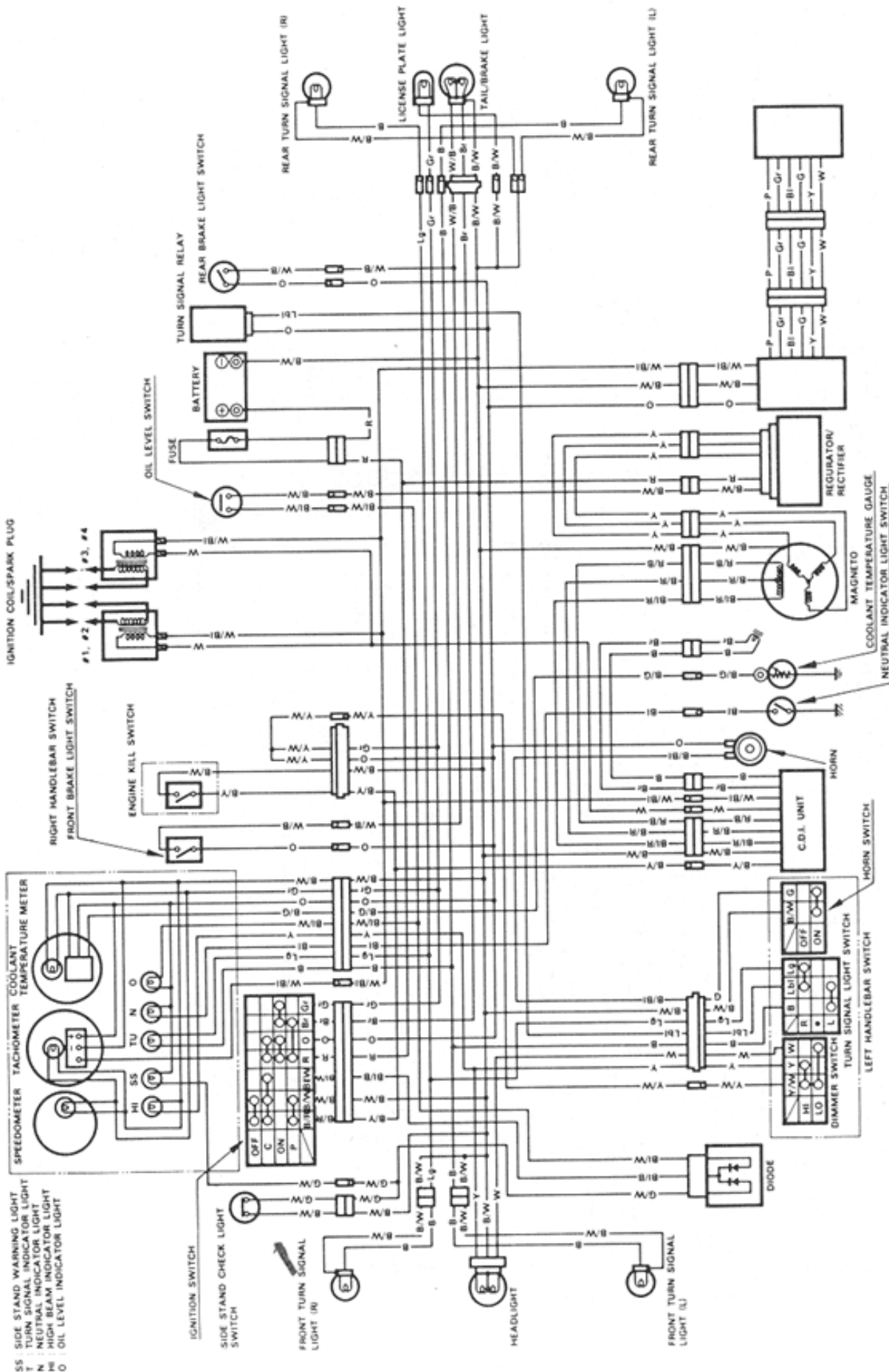

SS SIDE STAND WARNING LIGHT  
 T TURN SIGNAL INDICATOR LIGHT  
 N NEUTRAL INDICATOR LIGHT  
 HI HIGH BEAM INDICATOR LIGHT  
 O OIL LEVEL INDICATOR LIGHT

**WIRE COLOR**

B	.....	Black
Bl	.....	Blue
Br	.....	Brown
G	.....	Green
Gr	.....	Gray
Lbl	.....	Light blue
Lg	.....	Light green
O	.....	Orange
R	.....	Red
W	.....	White
Y	.....	Yellow
B/Bl	.....	Black with Blue tracer
B/G	.....	Black with Green tracer
B/R	.....	Black with Red tracer
B/W	.....	Black with White tracer
B/Y	.....	Black with Yellow tracer
Bl/R	.....	Blue with Red tracer
Bl/W	.....	Blue with White tracer
G/W	.....	Green with White tracer
O/R	.....	Orange with Red tracer
R/B	.....	Red with Black tracer
W/B	.....	White with Black tracer
W/Bl	.....	White with Blue tracer
Y/W	.....	Yellow with White tracer

(The others)

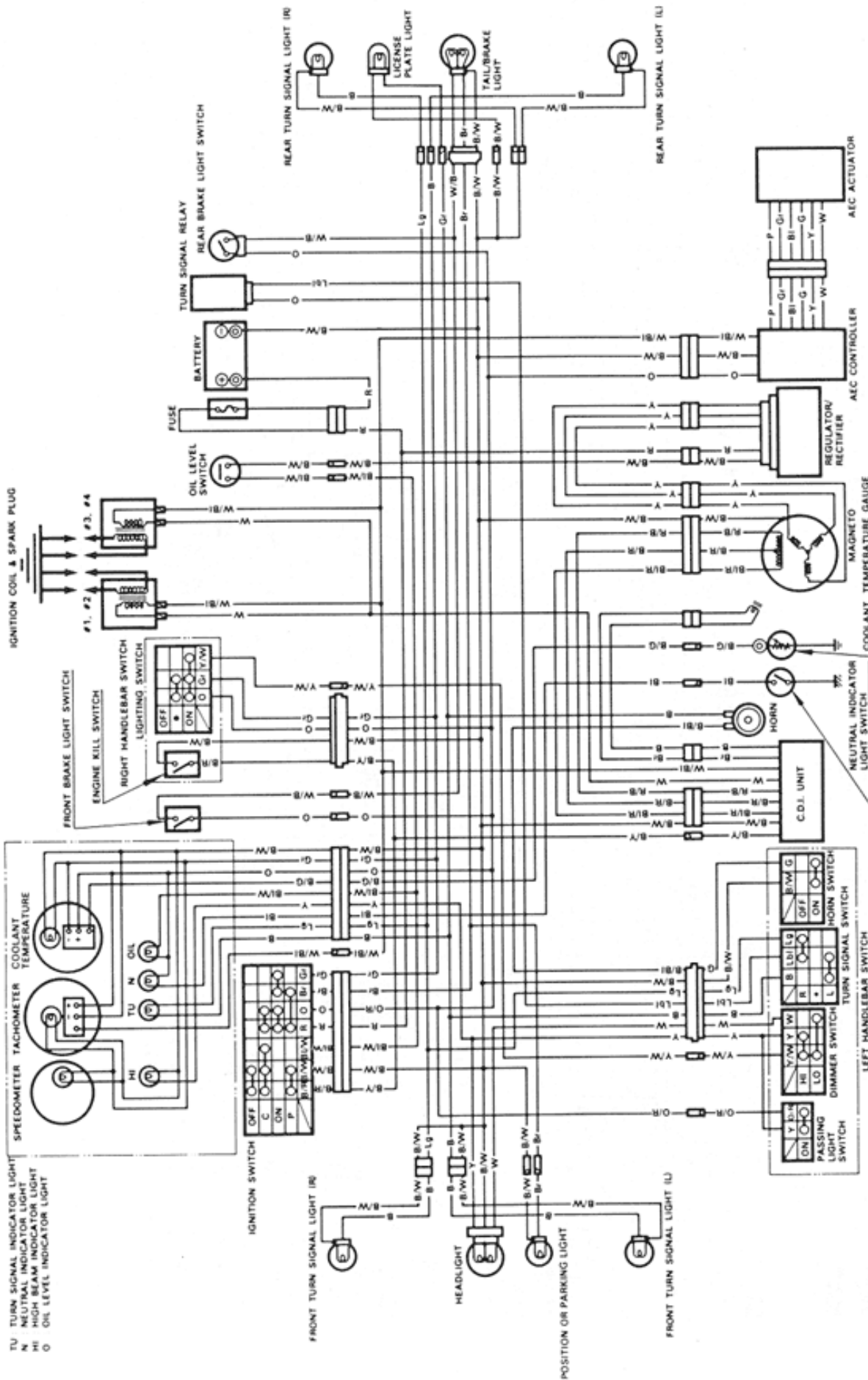

WIRE COLOR

- B ..... Black
- Bl ..... Blue
- Br ..... Brown
- G ..... Green
- Gr ..... Gray
- Lbl ..... Light blue
- Lg ..... Light green
- O ..... Orange
- R ..... Red
- W ..... White
- Y ..... Yellow
- B/B ..... Black with Blue tracer
- B/G ..... Black with Green tracer
- B/R ..... Black with Red tracer
- B/W ..... Black with White tracer
- B/Y ..... Black with Yellow tracer
- Bl/R ..... Blue with Red tracer
- Bl/W ..... Blue with White tracer
- G/W ..... Green with White tracer
- O/R ..... Orange with Red tracer
- R/B ..... Red with Black tracer
- W/B ..... White with Black tracer
- W/Bl ..... White with Blue tracer
- Y/W ..... Yellow with White tracer

# CABLE, HARNESS AND HOSE ROUTING

## CABLE ROUTING

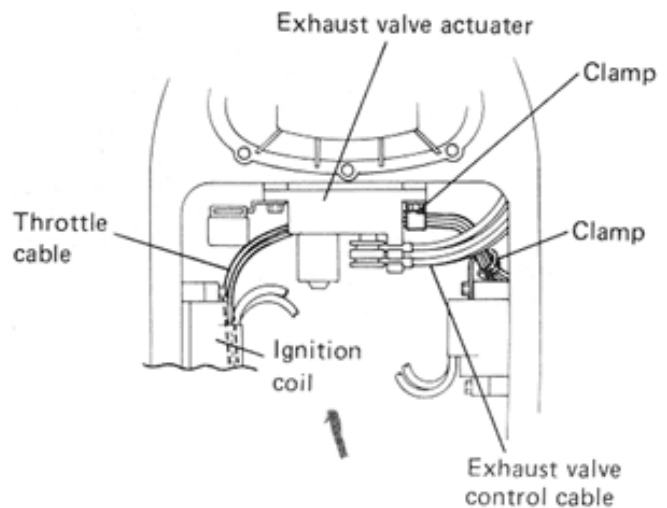
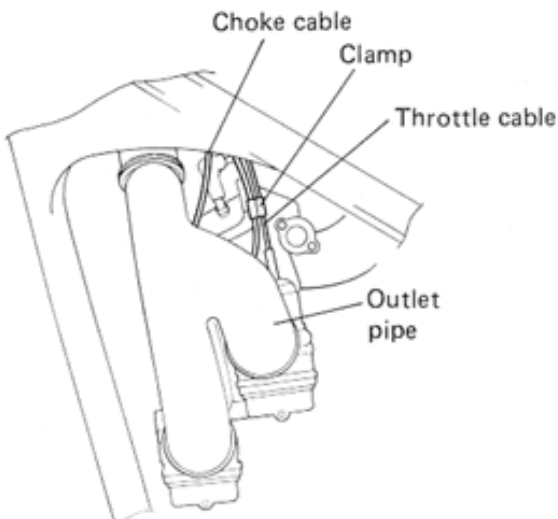
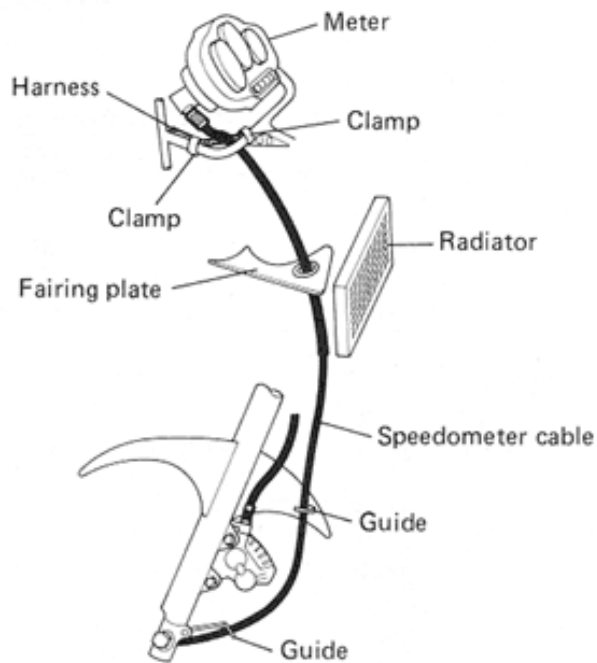
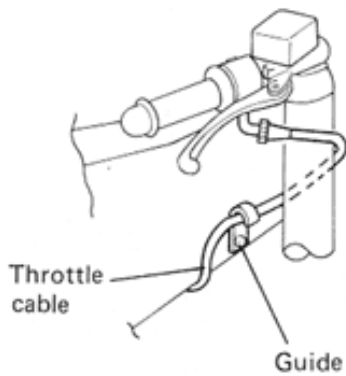
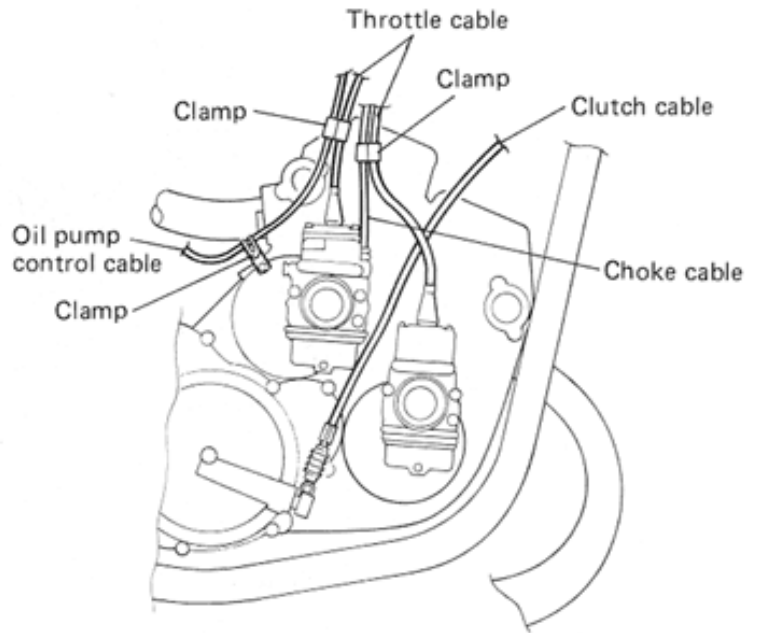
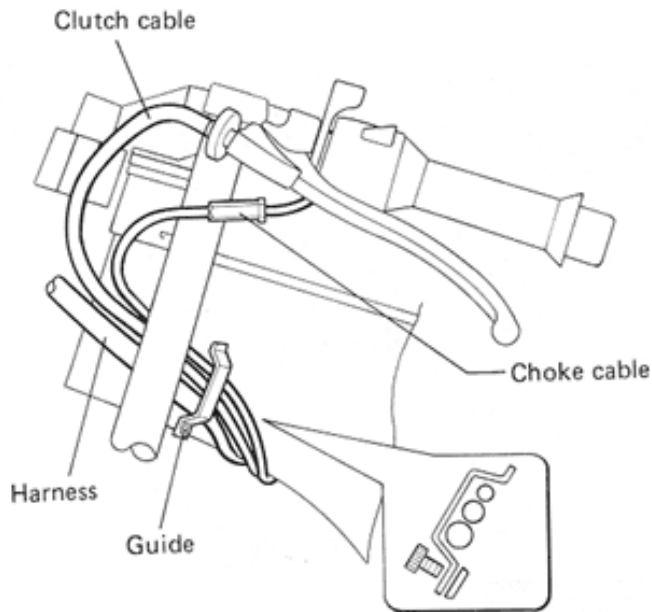

WIRING HARNESS ROUTING

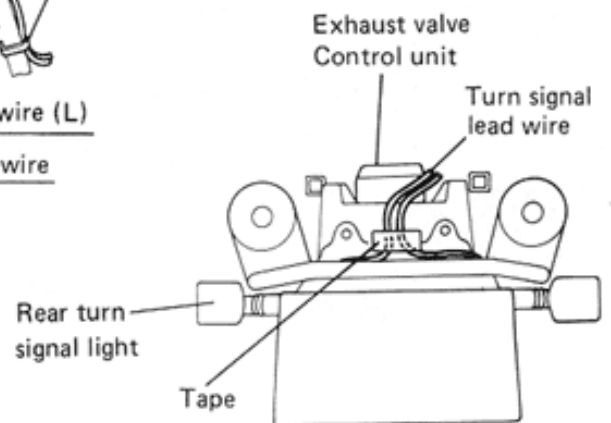
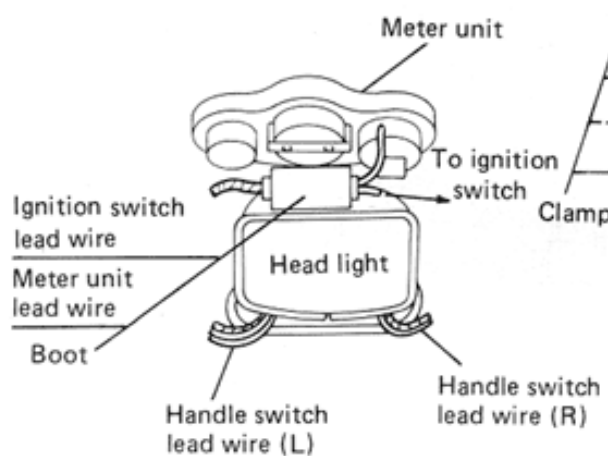
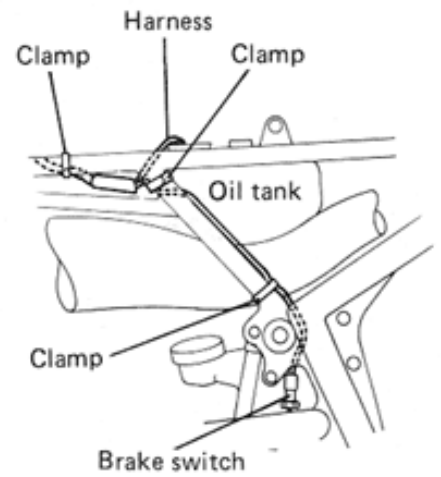
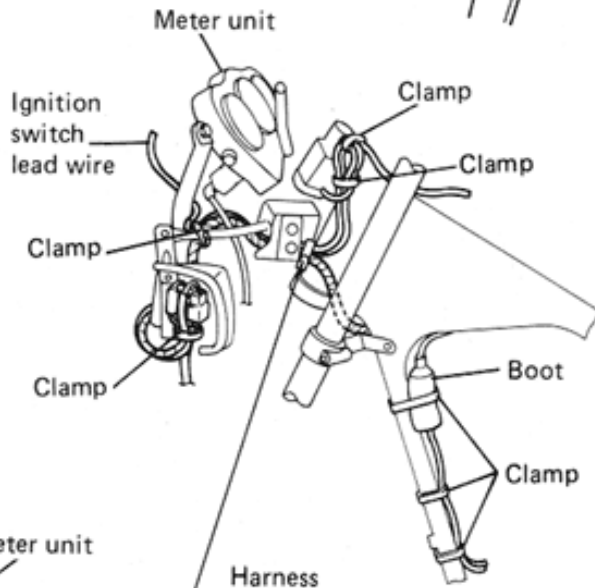
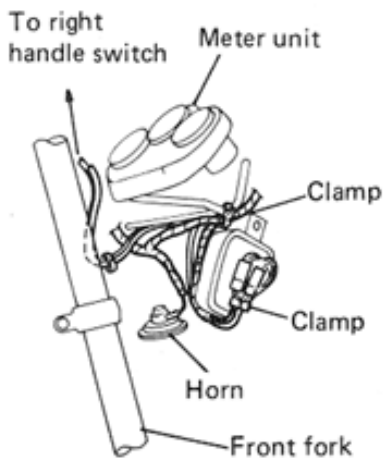
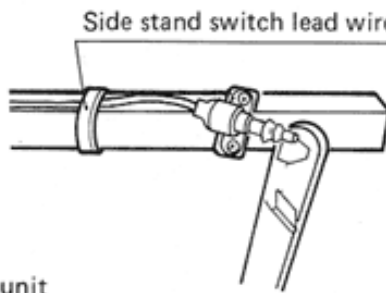
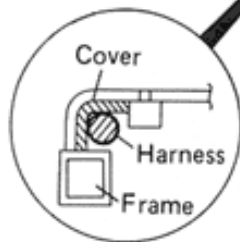
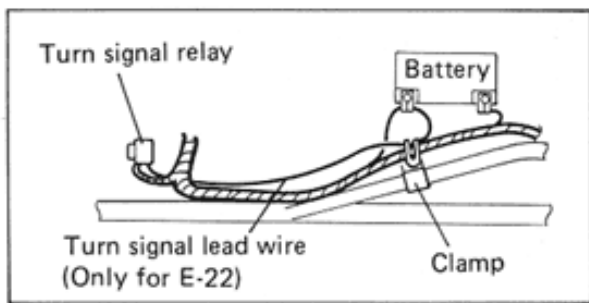
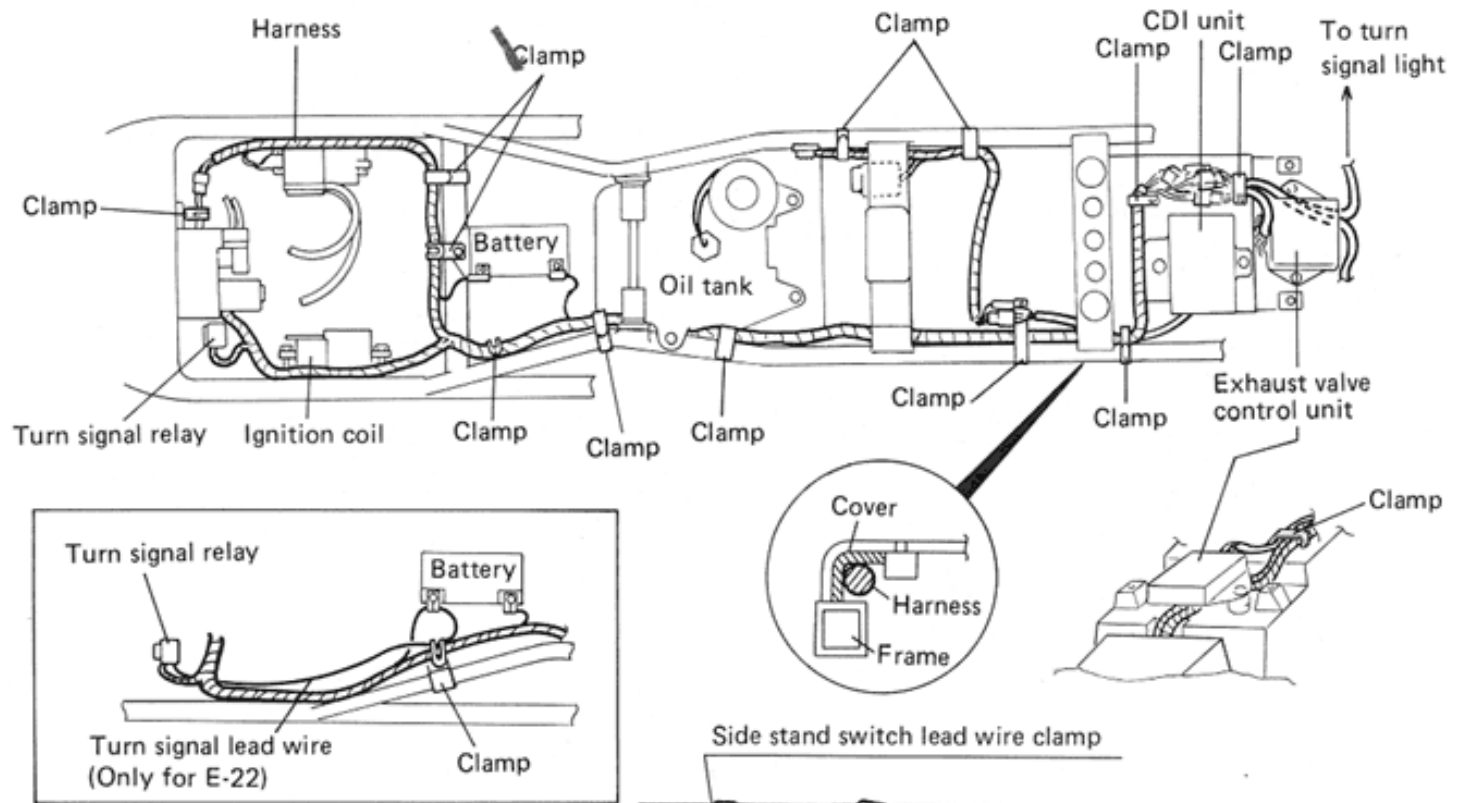

# OIL PUMP AND CARBURETOR HOSE ROUTING

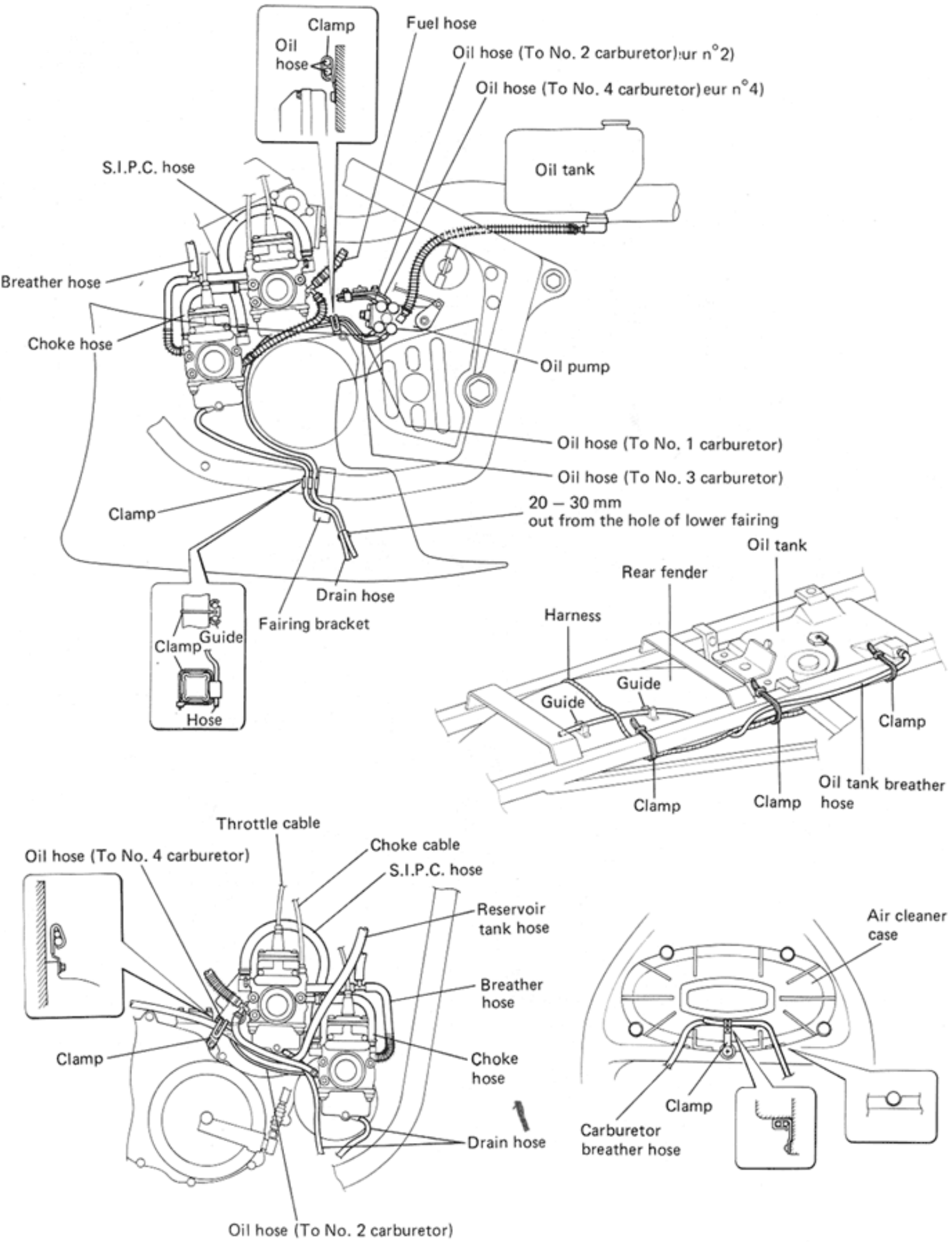

# FUEL HOSE ROUTING

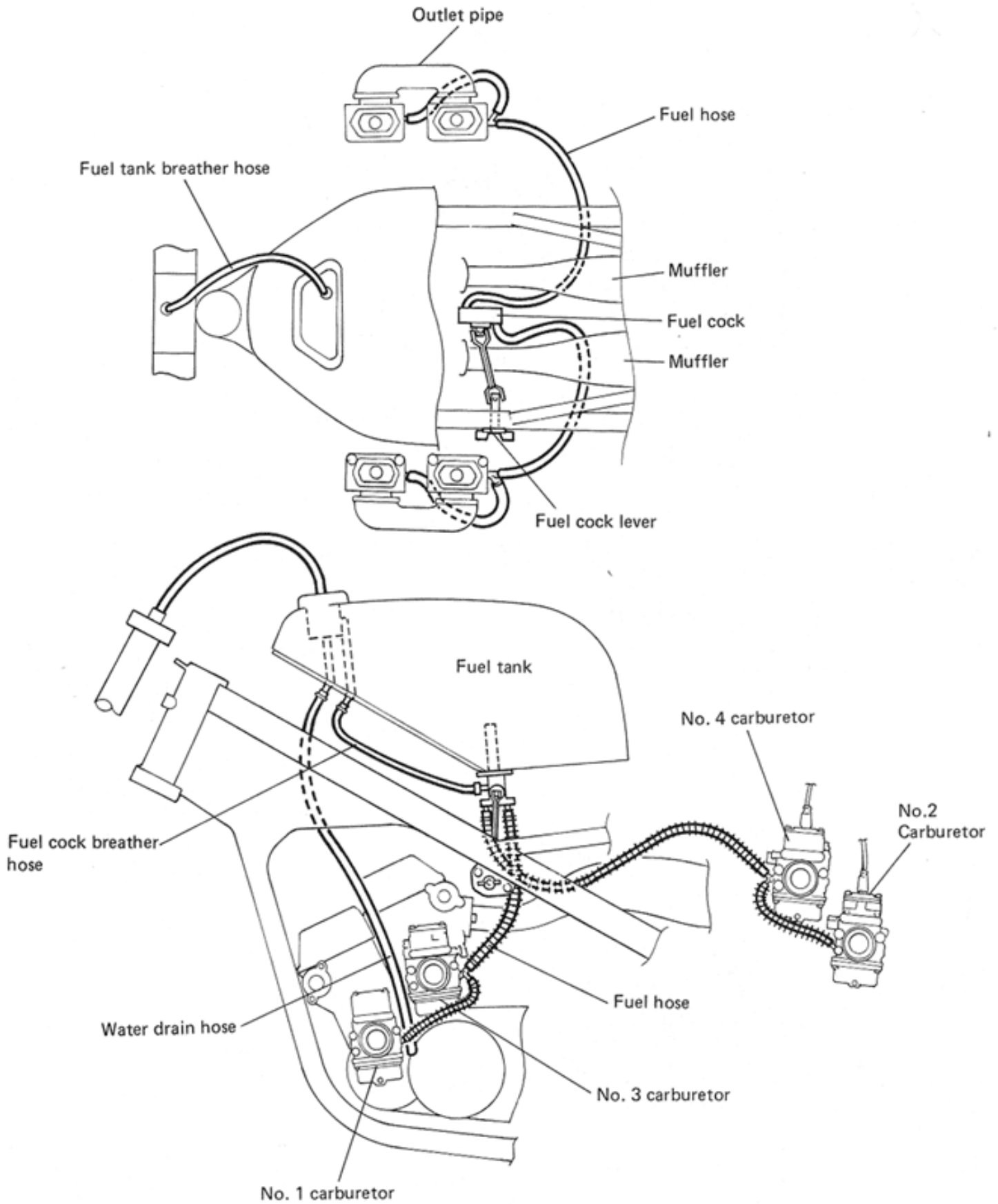

**STATOR LEAD WIRE ROUTING**

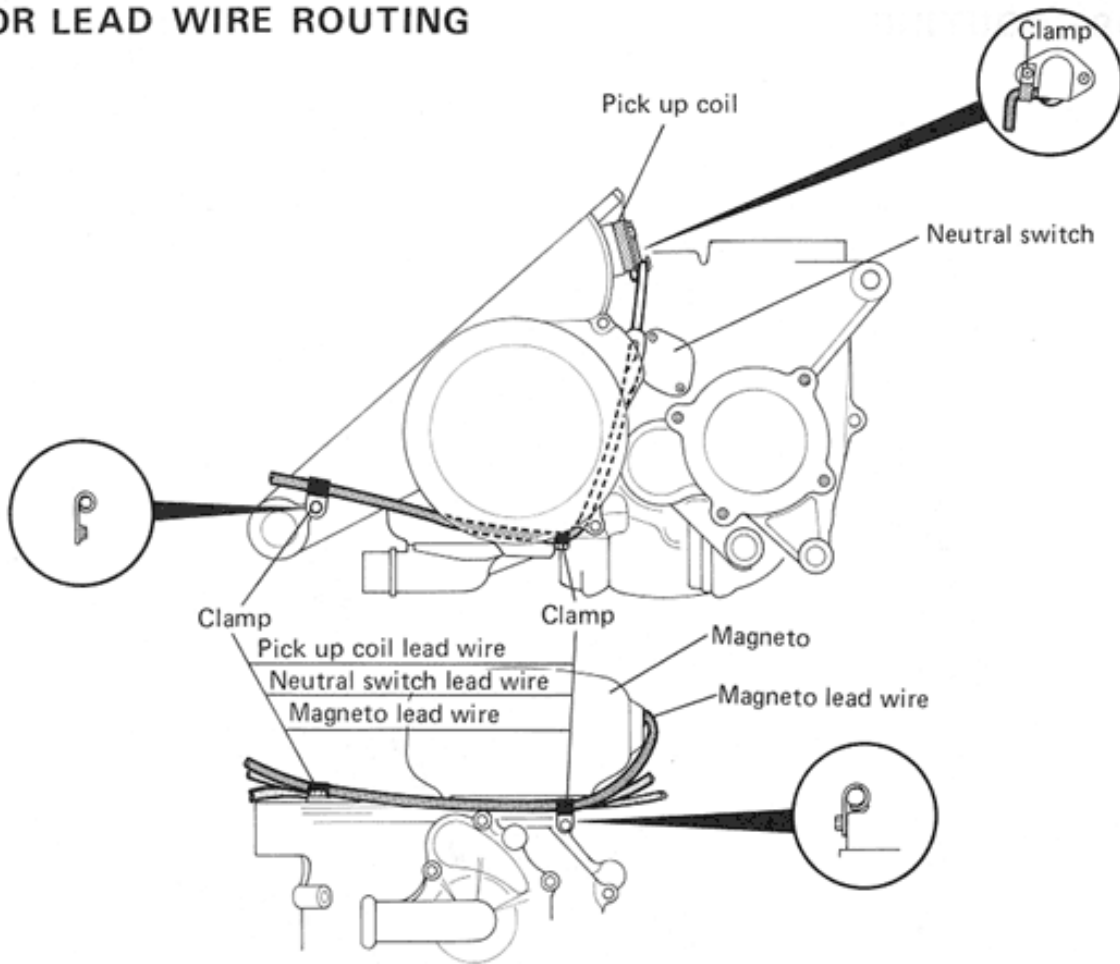

**TRANSMISSION CASE BREATHER HOSE ROUTING**

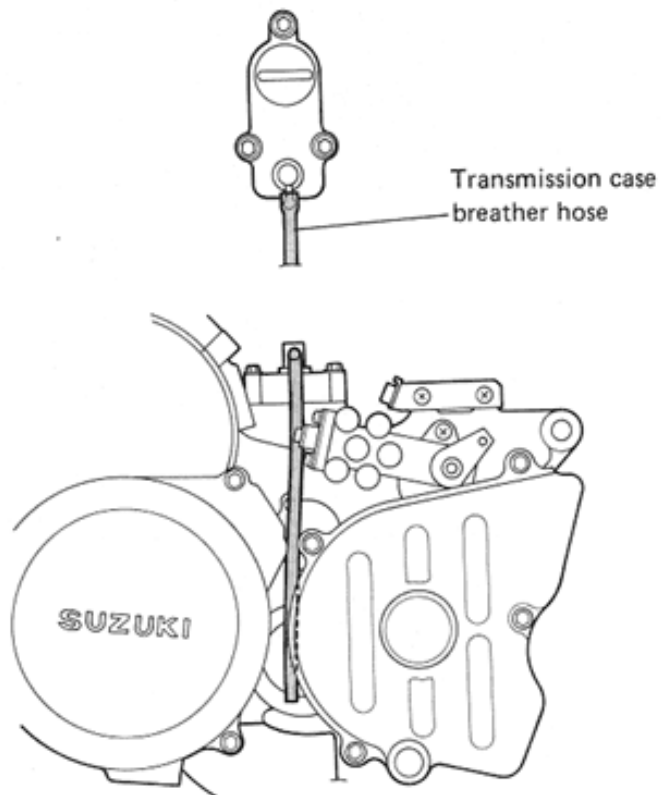



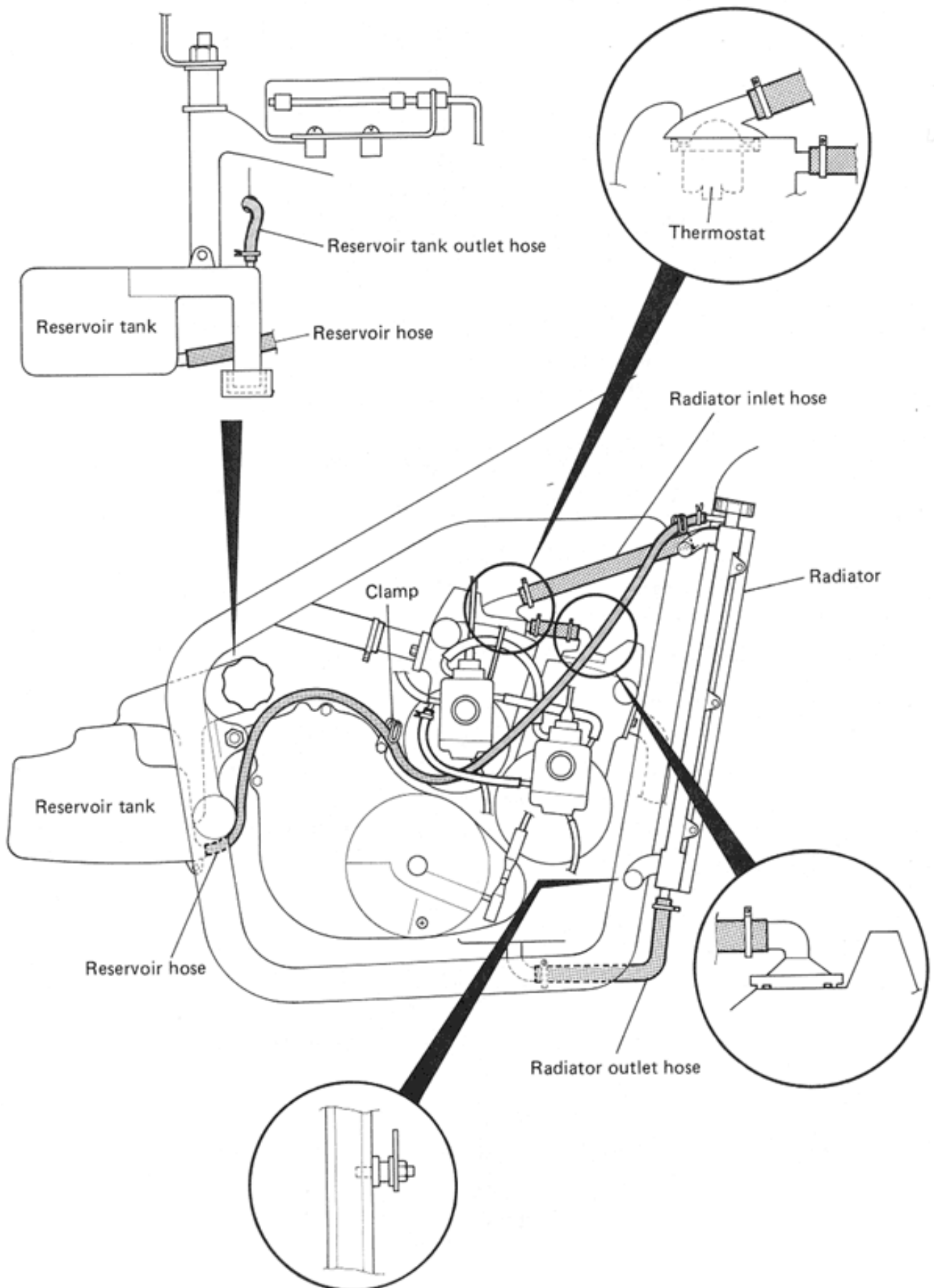





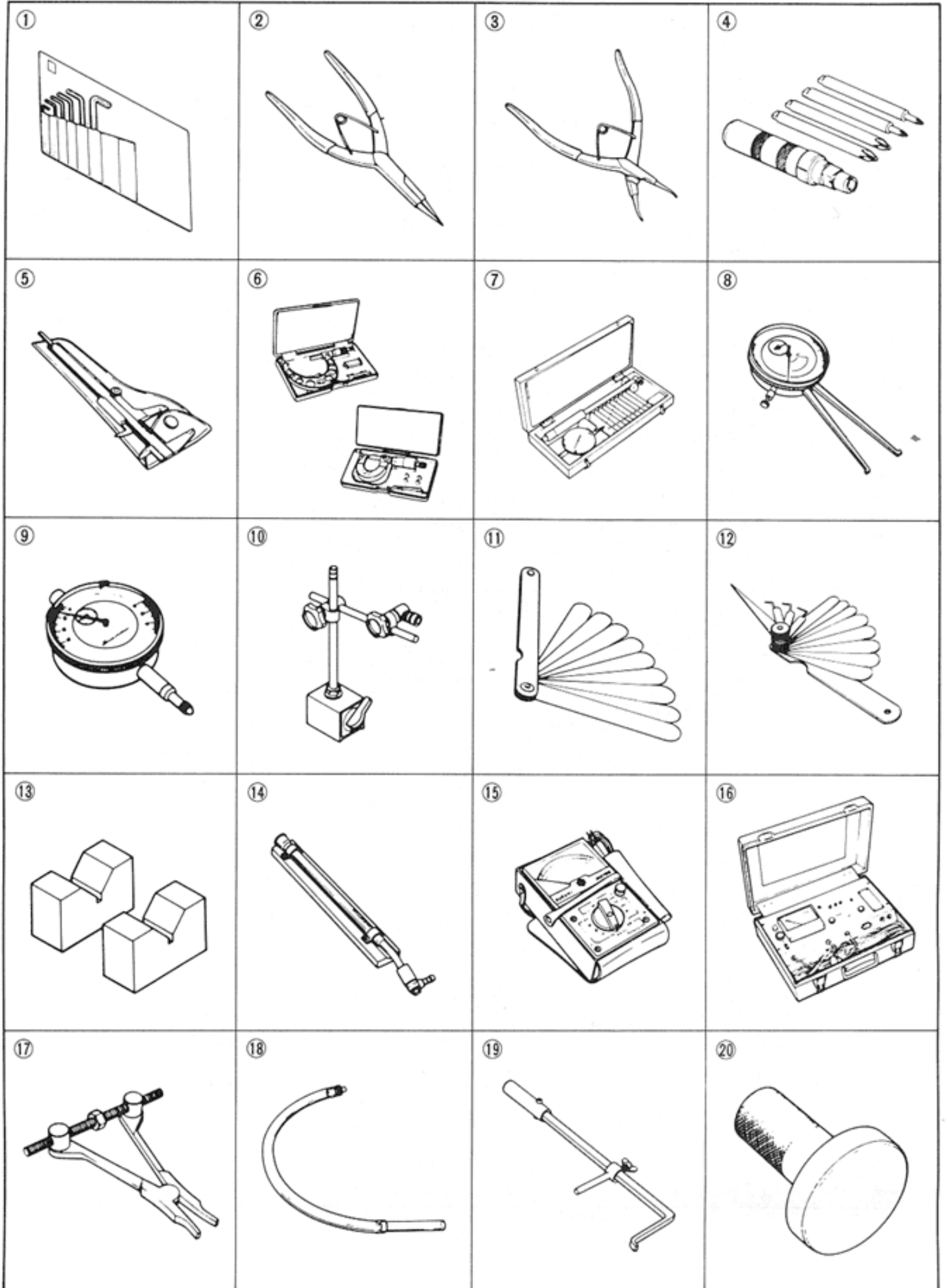



# WATER HOSE ROUTING

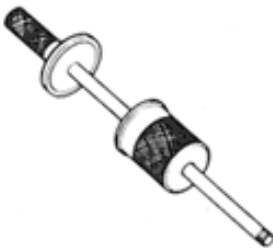

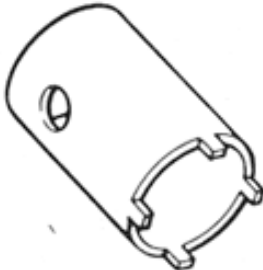
## SPECIAL TOOLS

Item	Part No.	Part Name
①	09900-00401	Hexagon wrench set
②	09900-06107	Snap ring pliers (Open type)
③	09900-06108	Snap ring pliers (Close type)
④	09900-09003	Impact driver set
⑤	09900-20102	Vernier calipers
⑥	09900-20203	Micrometer (50 – 75 mm)
	09900-20205	Micrometer (0 – 25 mm)
⑦	09900-20508	Cylinder gauge set
⑧	09900-20605	Dial calipers
⑨	09900-20606	Dial gauge (1/100 mm)
⑩	09900-20701	Magnetic stand
⑪	09900-20803	Thickness gauge
⑫	09900-20804	Thickness gauge
⑬	09900-21304	Steel "V" block set (100 mm)
⑭	09900-21602	CCI oil gauge
⑮	09900-25002	Pocket tester
⑯	09900-28106	Electro-tester
⑰	09912-34510	Cylinder disassembling tool
⑱	09913-14511	Fuel level gauge
⑲	09913-50121	Oil seal remover
⑳	09913-75520	Bearing installer
㉑	09920-53722	Clutch sleeve hub holder
㉒	09923-73210	Bearing puller
㉓	09924-84510	Bearing installer set
㉔	09930-30102	Rotor remover slide shaft
㉕	09930-30161	Attachment "C"
㉖	09930-40113	Rotor holder
㉗	09940-14911	Steering nut socket wrench
㉘	09940-34520	"T" handle
㉙	09940-34581	Attachment "F"
㉚	09940-44120	Air pressure gauge
㉛	09940-50112	Front fork oil seal installer
㉜	09941-34513	Steering race and swingarm bearing installer
㉝	09941-50110	Wheel bearing remover
㉞	09941-54911	Steering outer race remover
㉟	09941-74910	Steering bearing installer
㊱	09941-84510	Bearing remover
㊲	09943-74111	Front fork oil level gauge

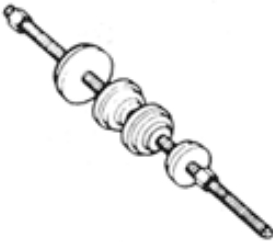
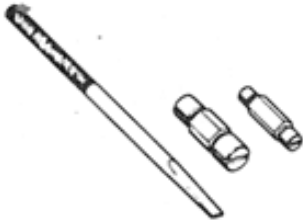
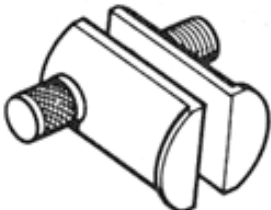

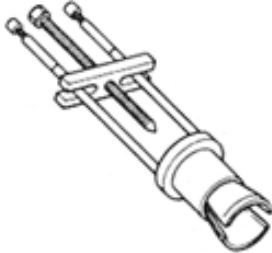
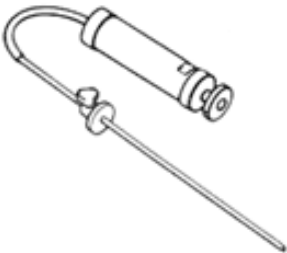
<p>21</p> 	<p>22</p> 	<p>23</p> 	<p>24</p> 
<p>25</p> 	<p>26</p> 	<p>27</p> 	<p>28</p> 
<p>29</p> 	<p>30</p> 	<p>31</p> 	<p>32</p> 
<p>33</p> 	<p>34</p> 	<p>35</p> 	<p>36</p> 
<p>37</p> 			

## TIGHTENING TORQUE

### ENGINE

Item		N·m	kg·m
Transmission oil drain plug	10 mm	15 – 20	1.5 – 2.0
	12 mm	18 – 23	1.8 – 2.3
Coolant drain plug		4 – 7	0.4 – 0.7
Exhaust pipe clamp bolt or nut		24 – 28	2.4 – 2.8
Muffler mounting bolt		21 – 25	2.1 – 2.5
Engine mounting bolt		60 – 72	6.0 – 7.2
Engine mounting bracket bolt		18 – 28	1.8 – 2.8
Engine sprocket nut		100 – 130	10.0 – 13.0
Kick starter lever bolt		18 – 28	1.8 – 2.8
Cylinder head bolt		10 – 12	1.0 – 1.2
Cylinder head nut		20 – 24	2.0 – 2.4
Cylinder bolt		23 – 27	2.3 – 2.7
Crankcase bolt	6 mm	9 – 13	0.9 – 1.3
	8 mm	20 – 24	2.0 – 2.4
Exhaust valve pulley bolt		4 – 7	0.4 – 0.7
Gearshift cam stopper bolt		15 – 23	1.5 – 2.3
Pilot shaft bearing holder bolt		20 – 24	2.0 – 2.4
Oil pan bolt		8 – 12	0.8 – 1.2
Primary drive gear bolt		90 – 110	9.0 – 11.0
Water pump cover bolt		8 – 12	0.8 – 1.2
Transmission cover nut		8 – 12	0.8 – 1.2
Clutch sleeve hub nut		50 – 70	5.0 – 7.0
Clutch spring bolt		8 – 12	0.8 – 1.2
Magneto rotor nut		120 – 140	12.0 – 14.0
Water pump impeller bolt		7 – 11	0.7 – 1.1
Water Temp. gauge		12 – 18	1.2 – 1.8
Radiator mounting nut		7 – 9	0.7 – 0.9
Carburetor mounting bolt		7 – 9	0.7 – 0.9

**CHASSIS**

Item	N·m	kg-m
Steering stem head bolt	20 – 30	2.0 – 3.0
Steering stem clamp bolt	15 – 25	1.5 – 2.5
Front fork upper clamp bolt	20 – 30	2.0 – 3.0
Front fork lower clamp bolt	20 – 30	2.0 – 3.0
Front fork cap bolt	25 – 35	2.5 – 3.5
Front fork damper rod bolt	34 – 46	3.4 – 4.6
Front axle nut	36 – 52	3.6 – 5.2
Front axle clamp nut	15 – 25	1.5 – 2.5
Handlebars mounting bolt	50 – 60	5.0 – 6.0
Front brake master cylinder mounting bolt	5 – 8	0.5 – 0.8
Front caliper mounting bolt	15 – 25	1.5 – 2.5
Front caliper housing bolt	30 – 36	3.0 – 3.6
Brake hose union bolt	20 – 25	2.0 – 2.5
Air bleeder valve (Front and rear)	6 – 9	0.6 – 0.9
Posi-damp unit bolt	6 – 8	0.6 – 0.8
Front and rear disc bolt	15 – 20	1.5 – 2.0
Swingarm pivot nut	50 – 80	5.0 – 8.0
Rear brake rod lock nut	15 – 25	1.5 – 2.5
Rear brake pedal bolt	6 – 10	0.6 – 1.0
Rear shock absorber mounting nut (Upper and lower)	48 – 72	4.8 – 7.2
Rear cushion lever nut	48 – 72	4.8 – 7.2
Rear cushion rod nut (Upper and lower)	48 – 72	4.8 – 7.2
Rear caliper mounting bolt	15 – 25	1.5 – 2.5
Rear caliper housing bolt	28 – 32	2.8 – 3.2
Rear torque link nut (Front and rear)	10 – 15	1.0 – 1.5
Rear master cylinder mounting bolt	5 – 8	0.5 – 0.8
Rear axle nut	50 – 80	5.0 – 8.0
Rear sprocket nut	48 – 72	4.8 – 7.2

**TIGHTENING TORQUE CHART**

For other bolts and nuts not listed above, refer to this chart:

Tightening torque

Bolt Diameter (mm)	Conventional or "4" marked bolt		"7" marked bolt	
	N·m	kg·m	N·m	kg·m
4	1 – 2	0.1 – 0.2	1.5 – 3	0.15 – 0.3
5	2 – 4	0.2 – 0.4	3 – 6	0.3 – 0.6
6	4 – 7	0.4 – 0.7	8 – 12	0.8 – 1.2
8	10 – 16	1.0 – 1.6	18 – 28	1.8 – 2.8
10	22 – 35	2.2 – 3.5	40 – 60	4.0 – 6.0
12	35 – 55	3.5 – 5.5	70 – 100	7.0 – 10.0
14	50 – 80	5.0 – 8.0	110 – 160	11.0 – 16.0
16	80 – 130	8.0 – 13.0	170 – 250	17.0 – 25.0
18	130 – 190	13.0 – 19.0	200 – 280	20.0 – 28.0

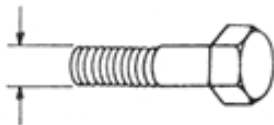

Conventional bolt

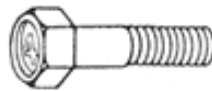

"4" marked bolt

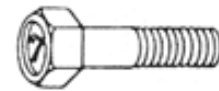

"7" marked bolt

## SERVICE DATA

### CYLINDER + PISTON + PISTON RING

Unit: mm

ITEM	STANDARD		LIMIT
Piston to cylinder clearance	0.065–0.075		0.120
Cylinder bore	56.000 – 56.015 Measure at 20 mm from the top surface		56.065
Piston diam.	55.930–55.945 Measure at 25 mm from the skirt end		55.880
Cylinder distortion	—		0.05
Cylinder head distortion	—		0.10
Piston ring free end gap	1st	T	Approx. 5.0
	2nd	T	Approx. 5.0
Piston ring end gap	0.15–0.30		0.75
Piston ring to groove clearance	1st		0.03–0.07
	2nd		0.01–0.05
Piston pin bore	14.002–14.010		14.030
Piston pin O.D.	13.994–14.000		13.980

### CONROD + CRANKSHAFT

Unit: mm

ITEM	STANDARD	LIMIT
Conrod small end I.D.	18.003–18.011	18.040
Conrod deflection	—	3.0
Crank web to web width	44.5–44.8	—
Crankshaft runout	—	0.05

### OIL PUMP

ITEM	SPECIFICATION
Oil pump reduction ratio	4.255 ( 54/54 × 58/26 × 29/11 × 21/29 )
CCI pump discharge rate (Full open)	3.2–4.0 ml for 1 minutes at 2 000 r/min.

### CLUTCH

Unit: mm

ITEM	STANDARD	LIMIT
Clutch cable play	2–3	—
Drive plate thickness	2.7 – 2.9	2.4
Drive plate claw width	13.85–13.96	13.05
Driven plate distortion	—	0.1
Clutch spring free length	—	34.9

### THERMOSTAT + RADIATOR

ITEM	STANDARD	LIMIT
Thermostat valve opening temperature	65 ± 2°C	—
Thermostat valve lift	Over 8 mm at 80°C	—
Radiator cap valve release pressure	90 ± 15 kPa (0.9 ± 0.15 kg/cm <sup>2</sup> )	—

**TRANSMISSION**

Unit: mm Excpet ratio

ITEM		STANDARD	LIMIT
Pilot drive and driven gear ratio		1.000 ( 54/54 )	—
Primary reduction ratio		2.230 ( 58/26 )	—
Final reduction ratio		2.500 ( 40/16 )	—
Gear ratios	Low	2.636 ( 29/11 )	—
	2nd	1.750 <sup>a</sup> ( 28/16 )	—
	3rd	1.380 ( 29/21 )	—
	4th	1.173 ( 27/23 )	—
	5th	1.045 ( 23/22 )	—
	Top	0.956 ( 22/23 )	—
Shift fork to groove clearance		0.10–0.30	0.50
Shift fork groove width		5.0–5.1	
Shift fork thickness		4.8–4.9	—
Gearshift lever height		40 – 45	

**DRIVE CHAIN**

Unit: mm

ITEM		STANDARD	LIMIT
Drive chain	Type	DAIDO: DID50VA TAKASAGO: RK50HFO	—
	Links	106	—
	20-pitch length	—	319.4
Drive chain slack		20–25	—

**CARBURETOR**

ITEM		SPECIFICATION
Carburetor type		MIKUNI VM28SH
Bore size		28 mm
I.D. No.		21A00
Idle r/min.		1 500 ± 150 r/min.
Fuel level		5.5 ± 0.5 mm
Float height		17.0 ± 1.0 mm
Main jet	(M.J.)	#120
Main air jet	(M.A.J.)	0.5 mm
Jet needle	(J.N.)	5CM1-2nd
Needle jet	(N.J.)	P-5
Cut-away	(C.A.)	2.0
Pilot jet	(P.J.)	#25
By-pass	(B.P.)	1.2 mm
Pilot outlet	(P.O.)	0.6 mm
Pilot air screw	(P.A.S.)	1 <sup>5</sup> / <sub>8</sub> turns back
Valve seat	(V.S.)	2.5
Starter jet	(G.S.)	#50
Throttle cable play		0.5–1.0 mm

ITEM	SPECIFICATION
Choke cable play	0.5–1.0 mm
Throttle valve setting position	0.5 mm from the main bore

**ELECTRICAL**

Unit: mm

ITEM	SPECIFICATION		NOTE
Ignition timing	14° B.T.D.C. below 1 700 r/min., 26° B.T.D.C. (2 700–6 000 r/min.) and 11° B.T.D.C. above 9 500 r/min.		
Exhaust valve	Open→close	7 800 r/min.	
	Close→open	7 500 r/min.	
Exhaust valve control cable play	0.5 mm		
Spark plug	Type	NGK: B9ES	E-01
	Gap	0.6–0.8	
	Type	NGK: BR9ES	The others
	Gap	0.6–0.8	
Spark performance	Over 8 at 1 atm.		
Ignition coil resistance	Primary	0.1–1.0 Ω	
	Secondary	10–30 kΩ	Plug cap – Plug cap
Pick-up coil resistance	85–135 Ω		B–Br
Stator coil resistance	0.1–1.0 Ω		Y–Y
	105–160 Ω		B/R–BI/R
	3–5 Ω		B/R–R/B
Generator no-load voltage	More than 53 V (AC) at 5 000 r/min.		
Regulated voltage	13.5–15.5 V at 5 000 r/min.		
Water temperature gauge resistance	190–260 Ω at 50°C		
	23–30 Ω at 115°C		
Battery	Type designation	YT5L-12	with special additive
	Capacity	12V14.4kC(4Ah)/10HR	
	Standard electrolyte S.G.	1.32 at 20°C (68°F)	
Fuse size	20 A		

**WATTAGE**

Unit: W

ITEM		SPECIFICATION			
		E-28	E-01,06,24	E-02	The others
Headlight	HI	60	←	←	←
	LO	55	←	←	←
Tail/Brake light		8/23	←	5/21	←
Turn signal light		23	←	21	←
Tachometer light		3	←	←	←
Water temp. meter light		1.7	←	←	←
Speedometer light		1.7	←	←	←
Turn signal indicator light		1.7	←	←	←
High beam indicator light		1.7	←	←	←

ITEM	SPECIFICATION			
	E-28	E-01,06,24	E-02	The others
Neutral indicator light	3	←	←	←
Oil level warning light	1.7	←	←	←
Side stand indicator light	3			
Parking or position light			3.4	4
License light	8	←	←	←

**BRAKE + WHEEL**

Unit: mm

ITEM	STANDARD		LIMIT
Rear brake pedal height	47.5		—
Brake disc thickness	Front	$4.5 \pm 0.2$	4.0
	Rear	$6.0 \pm 0.2$	5.3
Brake disc runout	—		0.30
Master cylinder bore	Front	14.000–14.043	—
	Rear	12.700–12.743	—
Master cylinder piston	Front	13.957–13.984	—
	Rear	12.657–12.684	—
Brake caliper cylinder bore	Front	27.000–27.076	—
	Rear	38.180–38.256	—
Brake caliper piston diam.	Front	26.920–26.970	—
	Rear	38.098–38.148	—
Wheel rim runout	Axial	—	2.0
	Radial	—	2.0
Wheel axle runout	Front	—	0.25
	Rear	—	0.25
Tire size	Front	110/90 V16	—
	Rear	120/90 V17	—
Tire tread depth	Front	—	1.6
	Rear	—	2.0

**SUSPENSION**

Unit: mm

ITEM	STANDARD	LIMIT	NOTE
Front fork stroke	130	—	
Front fork spring free length	—	417	
Front fork oil level	97	—	
Front fork air pressure	0 kPa (0 kg/cm <sup>2</sup> )	—	
Front fork damper position	2	—	
Front fork spring setting position	5th line from the top	—	
Rear shock absorber spring setting length	177.5	—	
Rear shock absorber spring setting position	3	—	
Rear wheel travel	127	—	
Swingarm pivot shaft runout	—	0.3	

**TIRE PRESSURE**

COLD INFLATION TIRE PRESSURE	SOLO RIDING		DUAL RIDING	
	kPa	kg/cm <sup>2</sup>	kPa	kg/cm <sup>2</sup>
FRONT	225	2.25	225	2.25
REAR	250	2.50	290	2.90

**FUEL + OIL + COOLANT**

ITEM	SPECIFICATION		NOTE
Fuel type	Gasoline used should be graded 85-95 octane or higher. An unleaded or low-lead type gasoline is recommended.		
Fuel tank including reserve	22.0 L		
reserve	5.0 L		
Engine oil type	SUZUKI CCI OIL or SUZUKI CCI SUPER OIL		
Engine oil tank capacity	1.5 L		
Transmission oil type	SAE 20W/40		
Transmission oil capacity	Change	800 ml	
	Overhaul	900 ml	
Front fork oil type	Fork oil #15		
Front fork oil capacity (each leg)	441 ml		
Brake fluid type	SAEJ1703, DOT3 or DOT4		
Coolant type	Use an anti-freeze/coolant compatible with aluminum radiator, mixed with distilled water only, at the ratio of 50 : 50.		
Coolant including reserve	2 250 ml		
reserve	250 ml		

# APPENDIX

## CONTENTS

<b>3RD/4TH DRIVE GEAR AND 5TH DRIVE GEARS</b> .....	<b>9-1</b>
<b>OVERFLOW PIPES ROUTING</b> .....	<b>9-2</b>
<b>TRANSMISSION OIL CAPACITY</b> .....	<b>9-4</b>

## 3RD/4TH DRIVE GEAR AND 5TH DRIVE GEAR

As shown below, the dogs of the 3rd/4th drive gear and the 5th drive gear were changed from the straight type to reverse taper type.

Due to the above modification, both 3rd/4th and 5th drive gears must be replaced for their secure engagement even when replacement of either one is necessary.

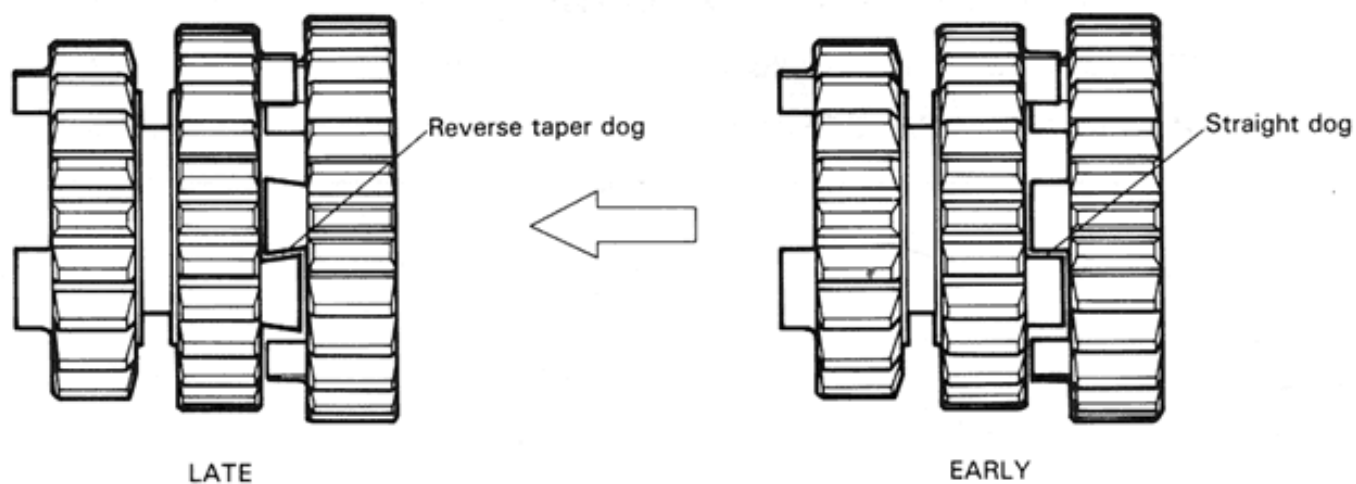

### PARTS SUPPLY DATA

PART NAME	LATE PART No.	EARLY PART No.
3rd/4th drive gear	24231-21A00	24231-20A01
5th drive gear	24251-21A00	24251-20A01

Note that only later type parts will be available, while early type parts supply will be stopped.

EFFECTIVE ENGINE NO.: ON AND AFTER E/NO. 102121 ~

## OVERFLOW PIPES ROUTING

Carburetor overflow pipes routing have been changed.

According to the above change two drilled holes have been added on the under cowling and length of the overflow pipes have been changed. When routing the carburetor overflow pipes, please refer to the following illustration.

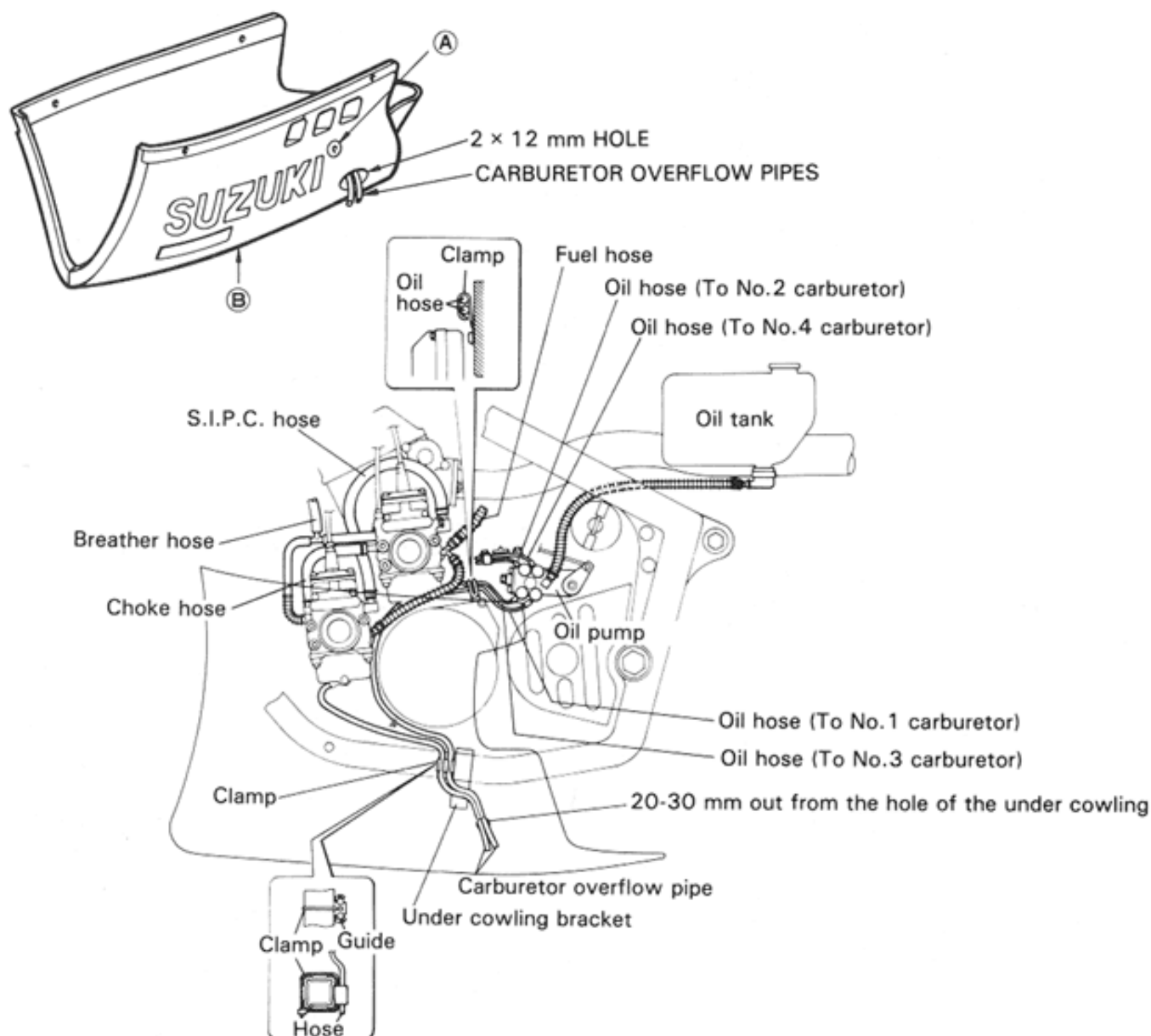

### \*LENGTH OF CARBURETOR OVERFLOW PIPES

	LATE		EARLY
FRONT LH (#1 cylinder)	325 MM	←	125 MM
FRONT RH (#2 cylinder)	275 MM	←	125 MM
REAR LH & RH (#3 & 4 cylinder)	375 MM	←	225 MM

At the same time, the spacer has been added inside the rubber spacer between under cowling and frame (at portion ① in the illustration) and also the resin washer has been added to the mating portion of RH and LH cowlings (at portion ② in the illustration).

**PORTION ①**

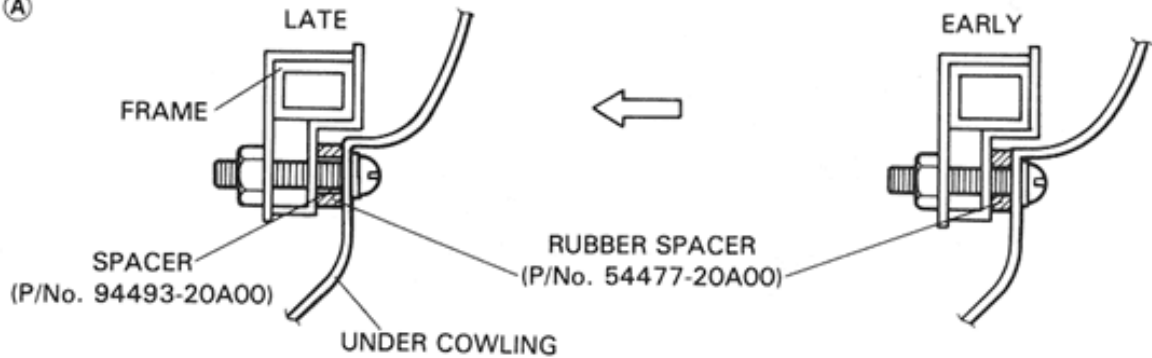

**PORTION ②**

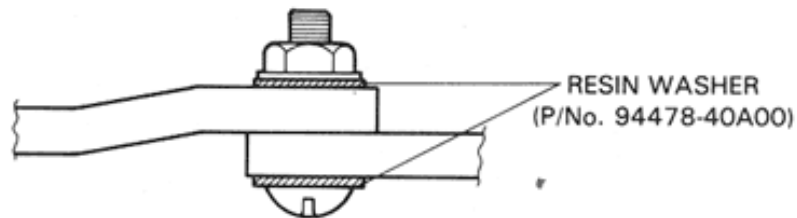

**\* PARTS SUPPLY DATA**

PARTS NAME	LATE PART No.		EARLY PART No.	Q'TY	REMARKS
UNDER COWLING	NO CHANGE	←	94470-20A00-14L -23Z	1 1	Overflow pipe holes have been provided.
SPACER	94493-20A00			2	Newly added (able to fit the early type cowling)
WASHER	94478-40A00			8	Newly added (able to fit the early type cowling)
OVERFLOW PIPE	13684-20A01 (375 mm)	←	13684-20A00 (225 mm)	4	When you install these pipes on each carburetor, you should cut pipes for No.1 and 2 carburetor to the proper lengths.
F, LH CARB. A'SSY	13201-21A30	←	13201-21A10	1	Part Nos. have been changed because of the change of overflow pipe. This change does not affect the carburetor settings.
R, LH CARB. A'SSY	13202-21A30	←	13202-21A10	1	
F, RH CARB. A'SSY	13301-21A30	←	13301-21A10	1	
R, RH CARB. A'SSY	13302-21A30	←	13302-21A10	1	

ON AND AFTER OCT. 1985 PRODUCTION

## TRANSMISSION OIL CAPACITY

The transmission oil capacity has been changed as shown below.

700 ml ⇨ 800 ml

When replacing the transmission oil, follow the procedure below.

- After draining the transmission oil completely, fit the two drain plugs ① and ② securely.
- Keep the motorcycle upright.
- Replenish good quality SAE 20W/40 multi-grade motor oil into the engine. The transmission will hold about 800 ml of oil.
- Install the filler cap correctly.
- Start the engine and allow it to run for several seconds at idling speed.
- Turn off the engine and wait for about one minute, and check the oil level with the oil level screw ③. If the oil does not run out from the hole, add oil until it runs out.
- Tighten the oil level screw ③.

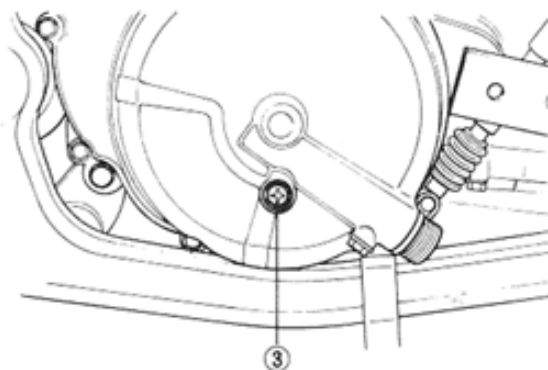
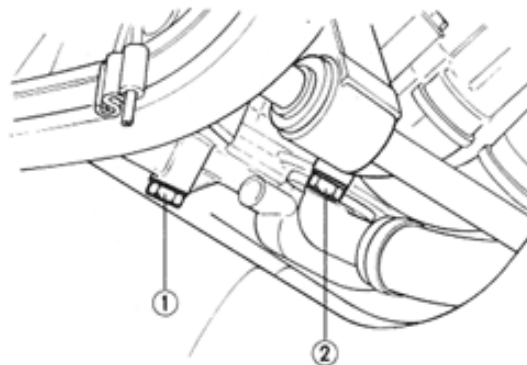
**CAUTION:**

To keep the correct oil capacity, do not tilt the motorcycle right and left, during the oil level checking.

# **RG500H ('87-MODEL)**

## **CONTENTS**

<b>SERVICE DATA</b> .....	<b>10-1</b>
<b>2ND AND 6TH DRIVEN GEARS</b> .....	<b>10-6</b>
<b>UNDER COWLING INSTALLATION</b> .....	<b>10-7</b>

## SERVICE DATA

### CYLINDER + PISTON + PISTON RING

Unit: mm

ITEM	STANDARD		LIMIT	
Piston to cylinder clearance	0.065–0.075		0.120	
Cylinder bore	56.000–56.015 Measure at 20 mm from the top surface		56.065	
Piston diam.	55.930–55.945 Measure at 25 mm from the skirt end		55.880	
Cylinder distortion	—		0.05	
Cylinder head distortion	—		0.10	
Piston ring free end gap	1st	T	Approx. 5.0	4.0
	2nd	T	Approx. 5.0	4.0
Piston ring end gap	0.15–0.30		0.75	
Piston ring to groove clearance	1st		0.03–0.07	—
	2nd		0.01–0.05	—
Piston pin bore	14.002–14.010		14.030	
Piston pin O.D.	13.994–14.000		13.980	

### CONROD + CRANKSHAFT

Unit: mm

ITEM	STANDARD	LIMIT
Conrod small end I.D.	18.003–18.011	18.040
Conrod deflection	—	3.0
Crank web to web width	44.5–44.8	—
Crankshaft runout	—	0.05

### OIL PUMP

ITEM	SPECIFICATION
Oil pump reduction ratio	4.255 ( 54/54 × 58/26 × 29/11 × 21/29 )
CCI pump discharge rate (Full open)	3.2–4.0 ml for 1 minutes at 2 000 r/min.

### CLUTCH

Unit: mm

ITEM	STANDARD	LIMIT
Clutch cable play	2–3	—
Drive plate thickness	2.7–2.9	2.4
Drive plate claw width	13.85–13.96	13.05
Driven plate distortion	—	0.1
Clutch spring free length	—	34.9

### THERMOSTAT + RADIATOR

ITEM	STANDARD	LIMIT
Thermostat valve opening temperature	65 ± 2°C	—
Thermostat valve lift	Over 8 mm at 80°C	—
Radiator cap valve release pressure	90 ± 15 kPa (0.9 ± 0.15 kg/cm <sup>2</sup> )	—

**TRANSMISSION**

Unit: mm Except ratio

ITEM		STANDARD	LIMIT
Pilot drive and driven gear ratio		1.000 ( 54/54 )	—
Primary reduction ratio		2.230 ( 58/26 )	—
Final reduction ratio		2.500 ( 40/16 )	—
Gear ratios	Low	2.636 ( 29/11 )	—
	2nd	1.750 ( 28/16 )	—
	3rd	1.380 ( 29/21 )	—
	4th	1.173 ( 27/23 )	—
	5th	1.045 ( 23/22 )	—
	Top	0.956 ( 22/23 )	—
Shift fork to groove clearance		0.10–0.30	0.50
Shift fork groove width		5.0–5.1	—
Shift fork thickness		4.8–4.9	—
Gearshift lever height		40–45	—

**DRIVE CHAIN**

Unit: mm

ITEM		STANDARD	LIMIT
Drive chain	Type	DAIDO: DID50VA TAKASAGO: RK50HFO	—
	Links	106	—
	20-pitch length	—	319.4
Drive chain slack		20 – 25	—

**CARBURETOR**

ITEM	SPECIFICATION
Carburetor type	MIKUNI VM28SH
Bore size	28 mm
I.D. No.	21A00
Idle r/min.	1 500 ± 150 r/min.
Fuel level	5.5 ± 0.5 mm
Float height	17.0 ± 1.0 mm
Main jet (M.J.)	#120
Main air jet (M.A.J.)	0.5 mm
Jet needle (J.N.)	5CM1-2nd
Needle jet (N.J.)	P-5
Cut-away (C.A.)	2.0
Pilot jet (P.J.)	#25
By-pass (B.P.)	1.2 mm
Pilot outlet (P.O.)	0.6 mm
Pilot air screw (P.A.S.)	1 <sup>5</sup> / <sub>8</sub> turns back
Valve seat (V.S.)	2.5
Starter jet (G.S.)	#50
Throttle cable play	0.5–1.0 mm

ITEM	SPECIFICATION
Choke cable play	0.5–1.0 mm
Throttle valve setting position	0.5 mm from the main bore

**ELECTRICAL**

Unit: mm

ITEM	SPECIFICATION		NOTE
Ignition timing	14° B.T.D.C. below 1 700 r/min., 26° B.T.D.C. (2 700–6 000 r/min.) and 11° B.T.D.C. above 9 500 r/min.		
Exhaust valve	Open→close	7 800 r/min.	
	Close→open	7 500 r/min.	
Exhaust valve control cable play	0.5		
Spark plug	Type	NGK: B9ES	E-01
	Gap	0.6–0.8	
	Type	NGK: BR9ES	The others
	Gap	0.6–0.8	
Spark performance	Over 8 at 1 atm.		
Ignition coil resistance	Primary	0.1–1.0 Ω	
	Secondary	10–30 kΩ	Plug cap – Plug cap
Pick-up coil resistance	85–135 Ω		B–Br
Stator coil resistance	0.1–1.0 Ω		Y–Y
	105–160 Ω		B/R–BI/R
	3–5 Ω		B/R–R/B
Generator no-load voltage	More than 53 V (AC) at 5 000 r/min.		
Regulated voltage	13.5–15.5 V at 5 000 r/min.		
Water temperature gauge resistance	190–260 Ω at 50°C		
	23–30 Ω at 115°C		
Battery	Type designation	YT5L-12	with special additive
	Capacity	12V14.4kC(4Ah)/10HR	
	Standard electrolyte S.G.	1.32 at 20°C (68°F)	
Fuse size	20 A		

**WATTAGE**

Unit: W

ITEM		SPECIFICATION			
		E-28	E-01,06,24	E-02	The others
Headlight	HI	60	←	←	←
	LO	55	←	←	←
Tail/Brake light		8/23	←	5/21	←
Turn signal light		23	←	21	←
Tachometer light		3	←	←	←
Water temp. meter light		1.7	←	←	←
Speedometer light		1.7	←	←	←
Turn signal indicator light		1.7	←	←	←
High beam indicator light		1.7	←	←	←

ITEM	SPECIFICATION			
	E-28	E-01,06,24	E-02	The others
Neutral indicator light	3	←	←	←
Oil level warning light	1.7	←	←	←
Parking or position light			3.4	4
License light	8	←	←	←

**BRAKE + WHEEL**

Unit: mm

ITEM	STANDARD		LIMIT
Rear brake pedal height	47.5		—
Brake disc thickness	Front	4.5 ± 0.2	4.0
	Rear	6.0 ± 0.2	5.3
Brake disc runout	—		0.30
Master cylinder bore	Front	14.000 – 14.043	—
	Rear	12.700 – 12.743	—
Master cylinder piston diam.	Front	13.957 – 13.984	—
	Rear	12.657 – 12.684	—
Brake caliper cylinder bore	Front	27.000 – 27.076	—
	Rear	38.180 – 38.256	—
Brake caliper piston diam.	Front	26.920 – 26.970	—
	Rear	38.098 – 38.148	—
Wheel rim runout	Axial	—	2.0
	Radial	—	2.0
Wheel axle runout	Front	—	0.25
	Rear	—	0.25
Tire size	Front	110/90 V16	—
	Rear	120/90 V17	—
Tire tread depth	Front	—	1.6
	Rear	—	2.0

**SUSPENSION**

Unit: mm

ITEM	STANDARD	LIMIT	NOTE
Front fork stroke	130	—	
Front fork spring free length	—	417	
Front fork oil level	97	—	
Front fork air pressure	0 kPa (0 kg/cm <sup>2</sup> )	—	
Front fork damper position	2	—	
Front fork spring setting position	5th line from the top	—	
Rear shock absorber spring setting length	177.5	—	
Rear shock absorber spring setting position	3	—	
Rear wheel travel	127	—	
Swingarm pivot shaft runout	—	0.3	

**TIRE PRESSURE**

COLD INFLATION TIRE PRESSURE	SOLO RIDING		DUAL RIDING	
	kPa	kg/cm <sup>2</sup>	kPa	kg/cm <sup>2</sup>
FRONT	225	2.25	225	2.25
REAR	250	2.50	290	2.90

**FUEL + OIL + COOLANT**

ITEM	SPECIFICATION		NOTE
Fuel type	Gasoline used should be graded 85-95 octane or higher. An unleaded or low-lead type gasoline is recommended.		
Fuel tank including reserve	22.0 L		
reserve	5.0 L		
Engine oil type	SUZUKI CCI OIL or SUZUKI CCI SUPER OIL		
Engine oil tank capacity	1.5 L		
Transmission oil type	SAE 20W/40		
Transmission oil capacity	Change	800 ml	
	Overhaul	900 ml	
Front fork oil type	Fork oil #15		
Front fork oil capacity (each leg)	441 ml		
Brake fluid type	SAEJ1703, DOT3 or DOT4		
Coolant type	Use an anti-freeze/coolant compatible with aluminum radiator, mixed with distilled water only, at the ratio of 50 : 50.		
Coolant including reserve	2 250 ml		
reserve	250 ml		

## 2ND AND 6TH DRIVEN GEARS

The dog hole of the 2nd driven gear and the dog of the 6th driven gear have been reshaped on and after the "H" model unit. Also, these gears are interchangeable as a set with those of "G" model motorcycles. Follow the instructions below when replacing the gears. As illustrated, the dog hole and dog have been changed from the straight type to the reverse taper type. Due to the above modification, both 2nd and 6th driven gears must be replaced together for their secure engagement even when replacement of either one is necessary.

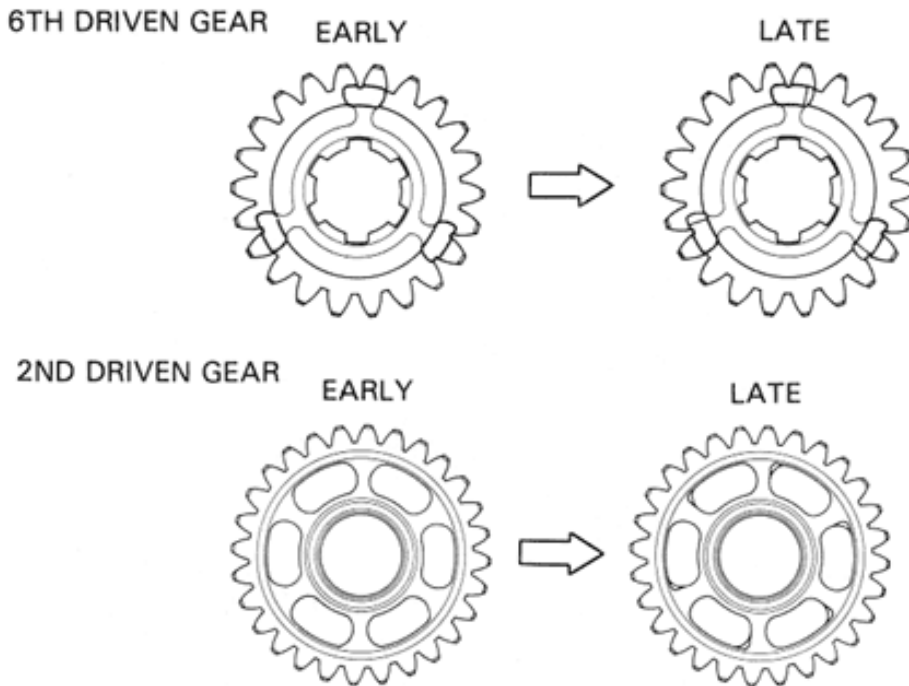

### PARTS SUPPLY DATA

PART NAME	LATE PART No.	EARLY PART No.
2ND DRIVEN GEAR	24320-21A10	24320-21A00
6TH DRIVEN GEAR	24361-21A10	24361-21A00

Both the late and early parts are available with the above part numbers and they are supplied individually. Use the late part numbers when placing an order.

## UNDER COWLING INSTALLATION

### 1. MODIFICATION

Refer to the installation diagram on pages 10-9 to 10-10.

- Part Fig A : The cushion is reshaped and the mounting of under cowling is changed to floating type.
- Part Fig B : A rubber cushion is used in place of a nylon washer and spacer is added to stabilize its tightening torque and changed to floating type.

The related parts are also modified in accordance with the above modification and they are shown in the installation diagram on pages 10-9 to 10-10.

### 2. PARTS SUPPLY

To cope with the above modification in installation, a special parts supply arrangement is made as described below. Read it carefully and note which type of spare parts will be supplied in each situation.

- The spare parts for "G" model are different from those for "H" model.
- The spare parts for "G" model will be modified in two steps as described in the table below.

① For "H" model . . . . . The parts shown in "Fig. B" in page 10-9 will be supplied.

② For "G" model

Type of spare parts Part name	Old supply parts (Fig. A)	1st modification (Fig. C)	2nd modification (Fig. D)
Under cowling	1st modification type spare parts (Fig. C) will be supplied.	As soon as the stock of this type runs out, 2nd modification type spare parts (Fig. D) will be supplied. 94470-20810-□□□ includes all installation parts.	Supply of this type will start when 1st modification type spare parts (Fig. C) run out of stock. 94470-20811-□□□ includes all installation parts.
Other installation parts	Available just as ever.	All available.	All available.

### 3. INTERCHANGEABILITY

- The under cowling or each of its installation parts alone is not interchangeable between any two types as shown below.
- Any two types are interchangeable provided that the under cowling and its installation parts of each type are changed as a set.

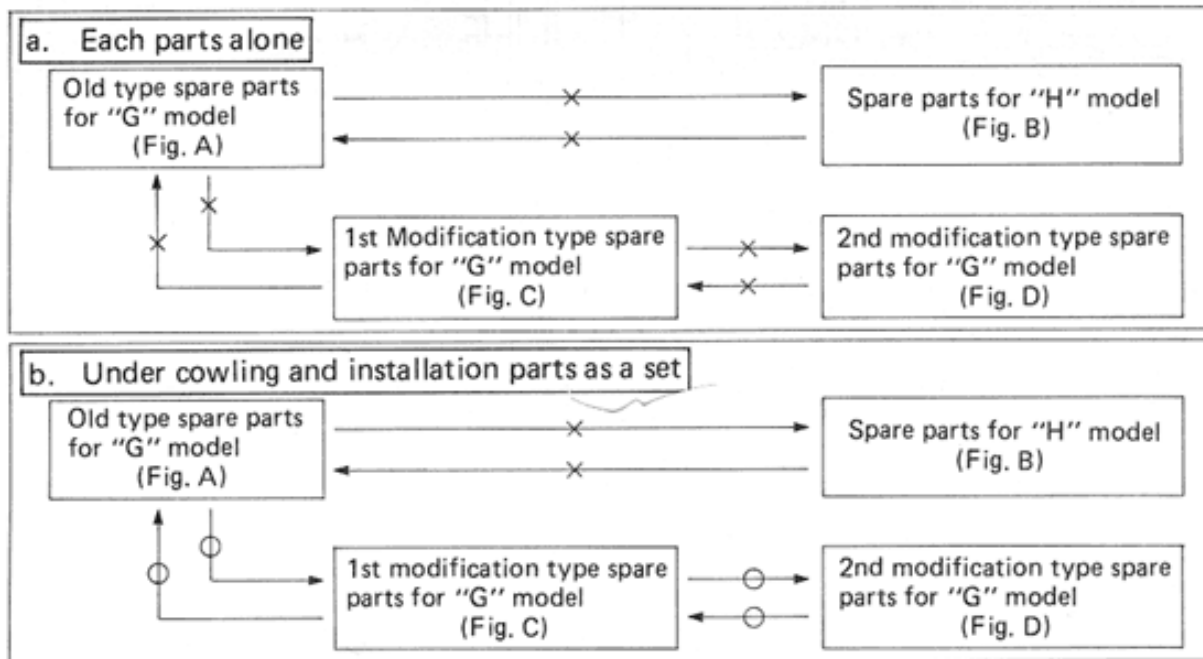

### 4. PRECAUTIONS IN INSTALLATION

1. Note that combination of installation parts varies depending on the shape and dimensions of the under cowling.
2. Given below are tightening torque specifications.

Part	Screw diameter	Tightening torque		
		kg-m	lb-ft	N·m
A	6 mm	0.2 – 0.4	1.5 – 3.0	2.0 – 4.0
B	5 mm	0.15 – 0.3	1.0 – 2.0	1.5 – 3.0

3. The spacer in Fig. B and Fig. C has a specific installation direction. Be sure to install properly as shown.
4. To change the way the under cowling is suspended while using the existing one of the old type (Fig. A), note the following.
  - Make the installation holes in the under cowling larger as follows.
    - Hole Ⓐ 9.5 mm (dia.) → 14 mm (dia.)
    - Hole Ⓑ 6.5 mm (dia.) → 8.0 mm (dia.)
  - For other installation parts, use the modified spare parts as shown in Fig. C.

Under cowling installation diagram

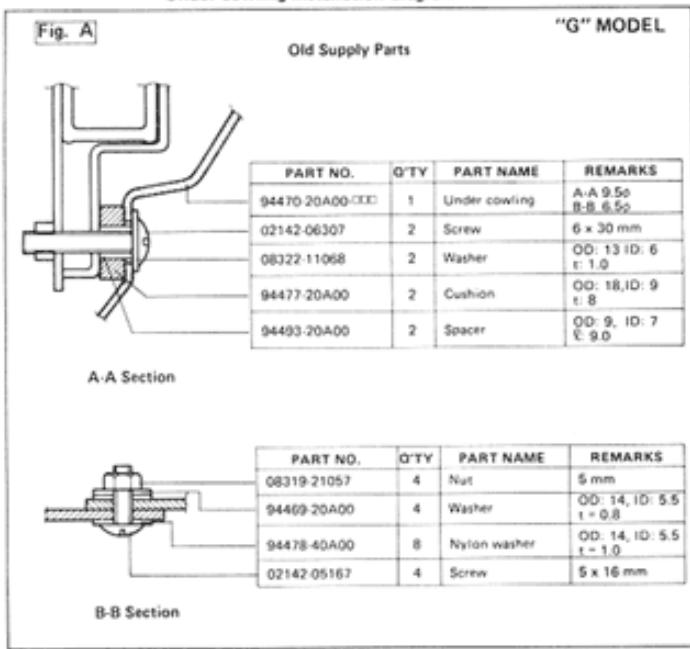

Modification for vehicle production

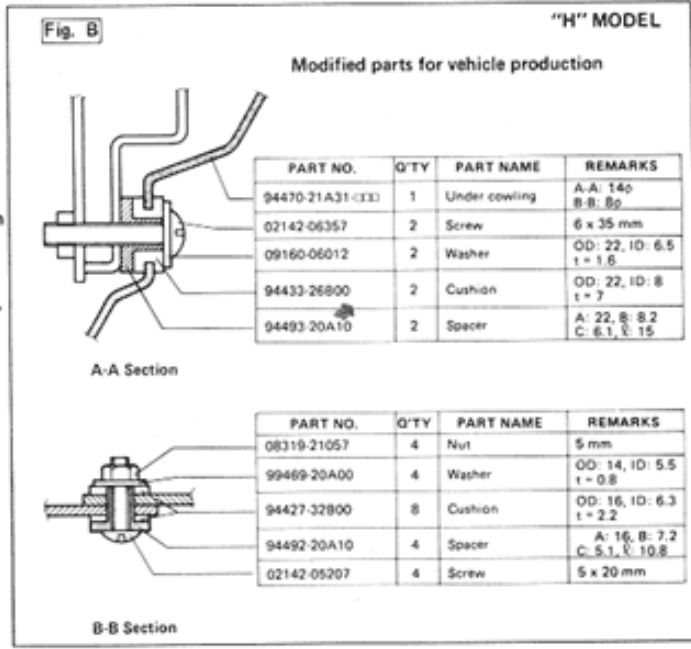

Modification for spare part

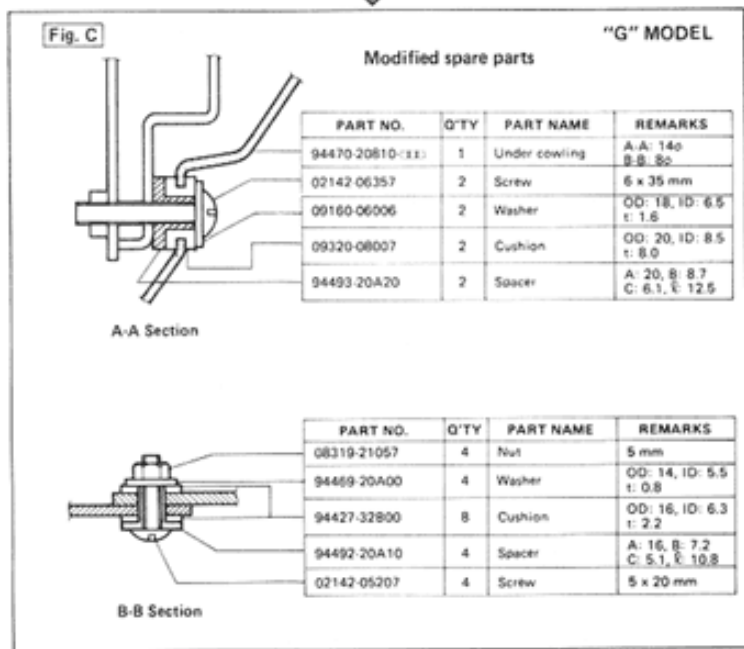

Modification for spare part

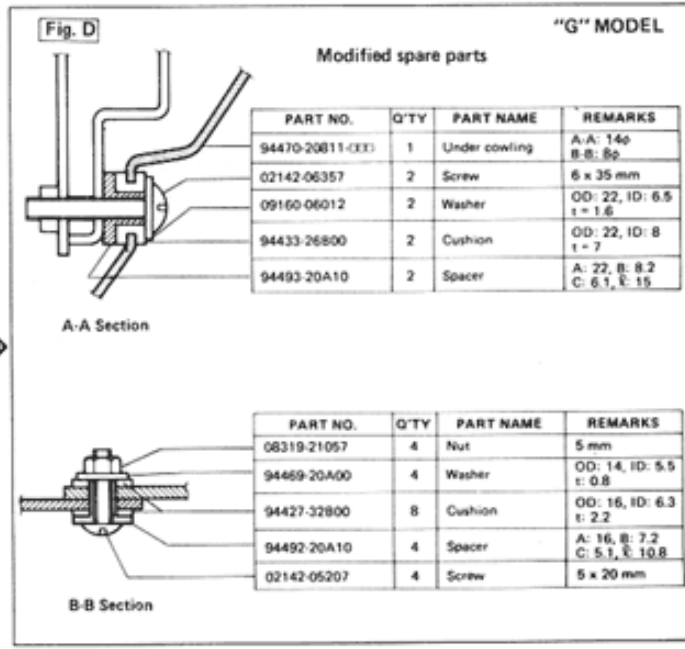

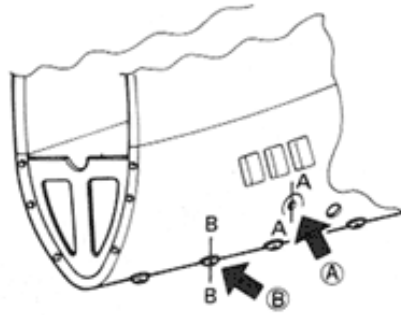

Part dimensions (example)

unit : mm

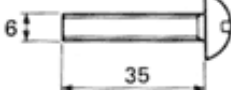
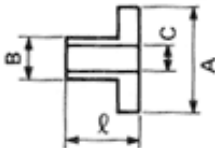
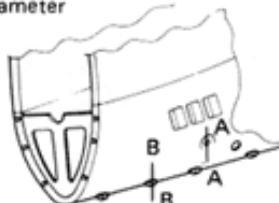
Screw	6 x 35 mm 
Washer, cushion	OD: Outer diameter ID: Inner diameter t: Thickness
Spacer	
Under cowling	Hole diameter 

Three types of under cowling (A-A section)

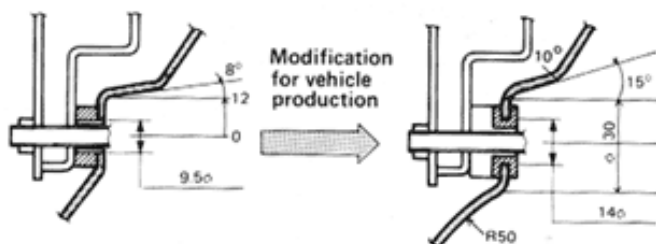

94470-20A00-000 (EMBLEM, SUZUKI)  
94470-21A00-000 (EMBLEM, Walter Mark)

94470-21A31-000 (EMBLEM "r")  
FOR "H" MODEL  
94470-20811-000 FOR G MODEL

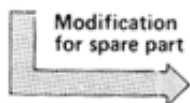

The only difference between  
94470-20A00-000 and  
94470-20810-000 is the hole  
diameter.

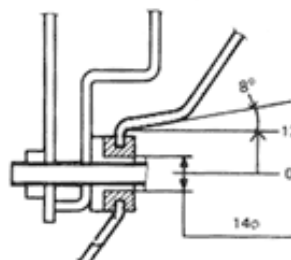

94470-20810-000 (EMBLEM, SUZUKI)  
94470-20860-000 (EMBLEM, Walter Mark)